

Radiant heating and cooling



**TECHNICAL
CATALOGUE**

01/2025



You Feel, We Care

*is our new tagline
and contains a renewed promise:
to work every day
with commitment and passion
while offering **tangible benefits**.*

*And we do this by developing systems
which are able to ensure
comfort and health
as well as a pleasant living space.*

*We continue to follow the principles
that have always inspired us :
the use of the **best materials**,
the research for **advanced technologies**,
and a **specialized service** for design,
technical assistance and training.*

*These are the same reasons
that guided us in
identifying the
perfect comfort system.*

*In our solution four elements
(surface heating/cooling, air handling,
temperature control, heat pumps)
interact synergistically
to spread in every room
the **ideal living conditions**,
in which our skin can perceive
a unique **feeling of wellbeing**.*



Table of Contents

CEILING AND WALL SYSTEMS	PAGE 4
<i>Traditional b!klimax</i>	PAGE 6
<i>b!klimax Air+</i>	PAGE 12
<i>b!klimax 8+ with plasterboard</i>	PAGE 20
<i>b!klimax 8+ HP</i>	PAGE 26
<i>b!klimax+ Quadrotti</i>	PAGE 34
<i>Complements for b!klimax systems</i>	PAGE 46
UNDERFLOOR RADIANT SYSTEMS WITH LOW THERMAL INERTIA	PAGE 54
<i>Rapid US</i>	PAGE 58
<i>Neo Super D17</i>	PAGE 64
<i>Super D</i>	PAGE 70
<i>Zero Level AD</i>	PAGE 76
<i>e-Dry Tech</i>	PAGE 82
<i>e-Dry Evo</i>	PAGE 88
TRADITIONAL UNDERFLOOR RADIANT SYSTEMS	PAGE 94
<i>Cover HP</i>	PAGE 98
<i>Cover</i>	PAGE 104
<i>Acoustic Plus</i>	PAGE 110
<i>AcuRapid</i>	PAGE 116
<i>Smooth Cover HP</i>	PAGE 122
<i>New Plus</i>	PAGE 128

T50 *PAGE 134*

TF HP *PAGE 140*

TF *PAGE 146*

PRL HP and PRL *PAGE 152*

MANIFOLDS, PIPES AND COMPLEMENTS *PAGE 160*

Manifolds *PAGE 162*

Piping *PAGE 173*

Other complements *PAGE 181*

Acoustic insulation for substrates *PAGE 182*

Additives *PAGE 184*

THERMOREGULATION DEVICES *PAGE 188*

GM and GR mixing and booster units *PAGE 190*

Mixing Box *PAGE 211*

Standard Kit *PAGE 215*

Valves and actuators *PAGE 222*

INDUSTRIAL UNDERFLOOR RADIANT SYSTEMS *PAGE 224*

Industrial shaped panel *PAGE 226*

PVC bars *PAGE 230*

Industrial mesh *PAGE 235*

Complements for industrial underfloor radiant systems *PAGE 240*



**Ceiling and wall
radiant systems**

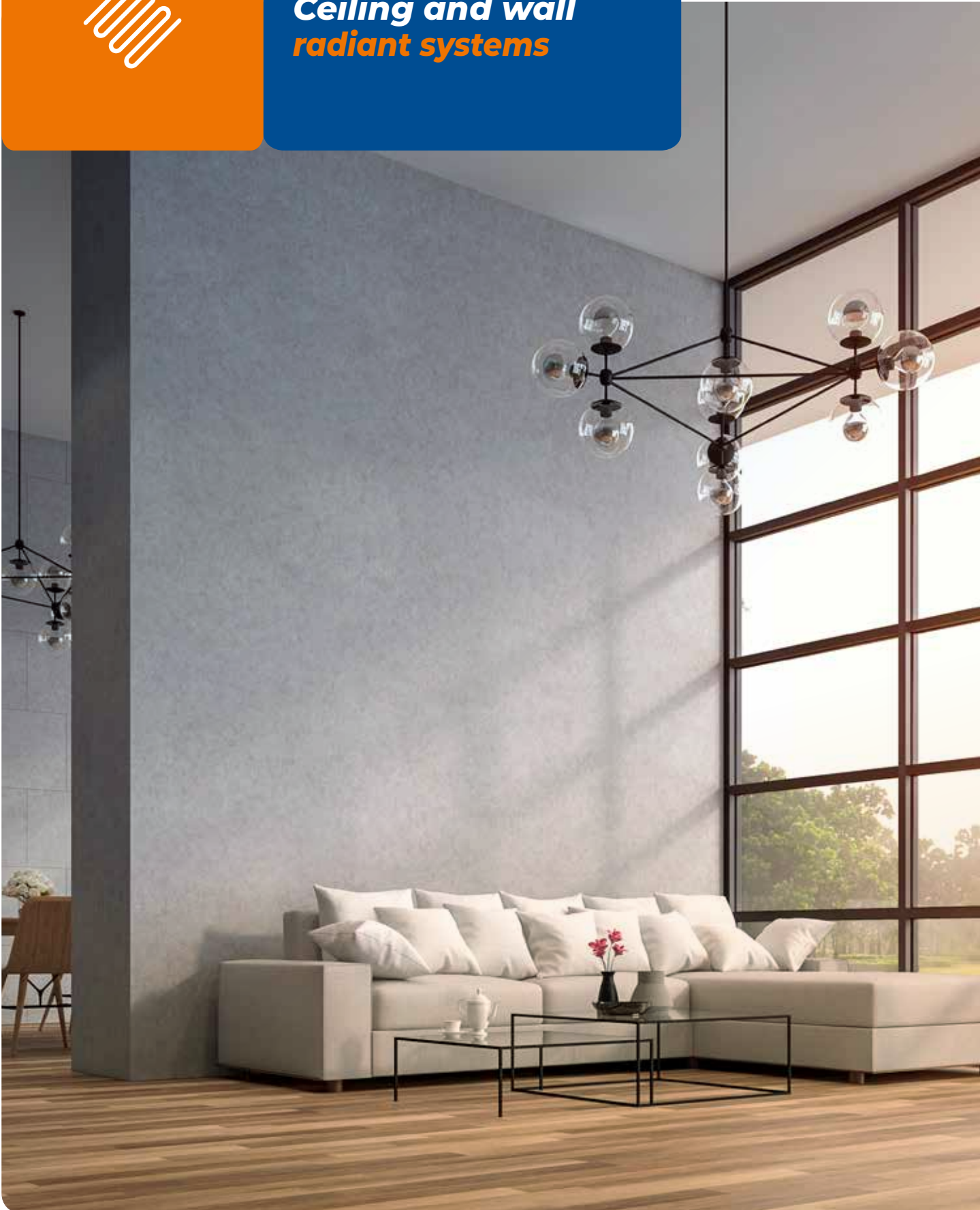



Widespread well-being

b!klimax is a heating and cooling system that exploits the ability of the ceilings and walls to exchange heat and cold through radiation with the room and with people. Thanks to the perfectly balance of the thermal exchanges, the human body perceived comfort is improved.

Available in different variants with metal, plasterboard or fibre-reinforced plaster finish, b!klimax provides the ideal climate in any building in the residential and commercial applications, either new or renovated.

In particular, it's indicated in situations where the lack of space makes it difficult to install a underfloor radiant system, for buildings with high room heights or for rooms where you want to preserve the existing flooring.

Invisible, responsive and easy to install, it offers high comfort in both summer and winter, healthy rooms, clutter-free spaces and maximum energy savings.

ADVANTAGES OF B!KLIMAX CEILING AND WALL SYSTEMS:



**INVISIBLE, COMFORTABLE
AND EFFICIENT**



**IDEAL FOR BOTH
HEATING AND COOLING**



**LOW THERMAL
INERTIA**



**ABSENCE OF
INVASIVE INTERVENTIONS**



**THERMALLY INSULATING
THE CEILING OR WALLS**



Traditional b!klimax is a ceiling and wall heating and cooling system characterised by high performance and the absence of thermal bridges, able to guarantee uniform temperature distribution, no air jets and great freedom of finishing.

The main components of the system are the 600 and 1200 polystyrene radiant panels shaped to place the \varnothing 6 mm pipe and covered with a layer of fibre-reinforced gypsum. This allows the system to be coated with any type of finish (plasterboard, plaster, matchboard, etc.).

The system is completed by the manifold, the distributors, the fittings, the \varnothing 20 mm polybutylene pre-insulated pipe for the connection of the distributors to the manifold, the \varnothing 6 mm polybutylene pipe for the connection of the panels to the distributors, the lubricant for push-fit fittings which facilitates the insertion of the pipe and favours the preservation of the o-rings and the retarder additive for the coupling of the plasterboard sheets to the radiant panels.

As the traditional b!klimax system is installed on a suspended metal structure, the gap between the radiant surface and the radiant panels can be used for other systems.

FEATURES

- Minimum recommended installation height 12 cm
- Ceiling or wall installation
- Low thermal inertia
- Polystyrene insulation
- Possibility of finishing with any non-insulating material
- Lightweight and easy to handle panels
- Particularly suitable for renovation
- Suitable for residential and commercial applications



SECTION OF THE SYSTEM

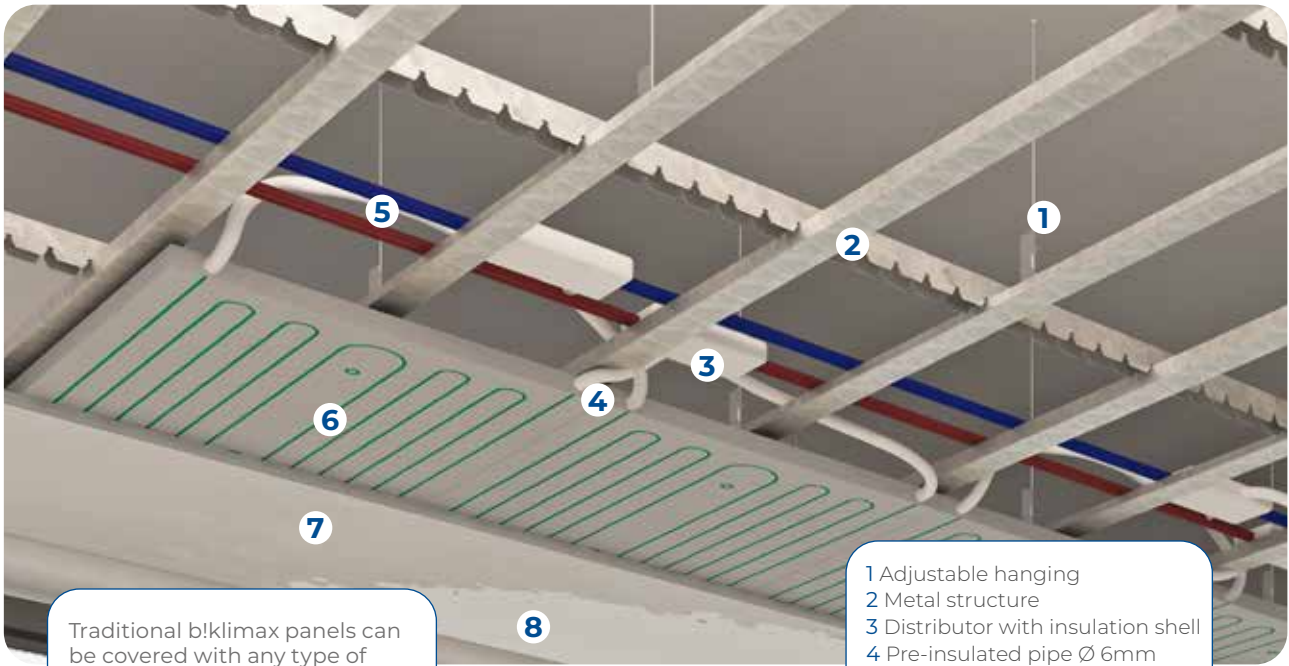

Traditional b!klimax panels can be covered with any type of plasterboard or finished directly with a reinforced skim coat.

- 1 Adjustable hanging
- 2 Metal structure
- 3 Distributor with insulation shell
- 4 Pre-insulated pipe Ø 6mm
- 5 Pipe Ø 20 mm
- 6 Radiant panels
- 7 Plasterboard sheet
- 8 Finish

METAL SUPPORT STRUCTURE

The **traditional b!klimax** radiant panels are designed to be installed both on walls and ceilings on common double metal frame structures for dry systems available on the market. Depending on the height of the rooms, it is possible to modulate the height of the pendant hooks according to specific requirements (aesthetic, based on the need to pass the ducts for other systems, etc.).

Hanging structure with snap profile

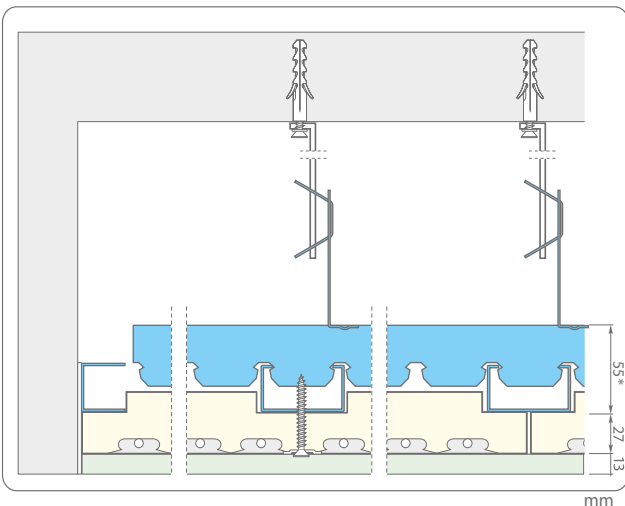

Structure with snap profile

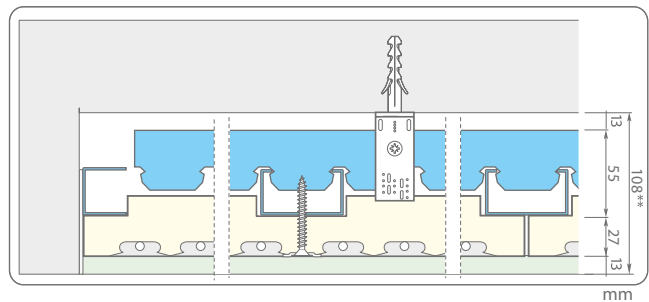

* Variable dimension depending on the profile used.

** If possible, to facilitate installation, we suggest a minimum height of 140 mm.

PRODUCTS THAT COMPOSE THE SYSTEM



Panel features

SIZE	WEIGHT	CODE
600x600x40 mm	3.1 Kg	6100595
1200x600x40 mm	6.7 Kg	6101200

Traditional b!klimax radiant panel

b!klimax radiant panel is made of polystyrene, thickness 40 mm, and it includes pipes \varnothing 6 mm with oxygen barrier according to DIN 4726. Panel and pipes are covered with a special layer of reinforced pre-plaster to increase their thermal output.

Polystyrene insulation characteristics		600	1200	Unit	Standard
Size of insulating panel		596x596	1202x596	mm	UNI EN 822
Standard thickness		39		mm	UNI EN 823
Insulation base thickness		30		mm	UNI EN 1264-3
Bending strength	BS	200		kPa	UNI EN 12089
Compressive stress at 10% deformation	CS(10)	150		kPa	UNI EN 826
Thermal conductivity 10 °C	λ_d	0.034		W/(m·K)	UNI EN 12667
Thermal resistance	Rd	0.95		(m ² ·K)/W	UNI EN 12667
Thermal transmittance	U	1.05		W/(m ² ·K)	
Water vapour diffusion resistance factor	μ	30 ÷ 70			UNI EN 12086
Water vapour permeability	δ	0.009 ÷ 0.020		mg/(Pa·h·m)	UNI EN 12086
Dimensional stability at 48h and 70 °C	DS(70,-)	1		%	UNI EN 1604
Long term water absorption by partial immersion	WIp	0.5		Kg/m ²	UNI EN 12087
Long term water absorption by total immersion	WI(T)	≤3		%	UNI EN 12087
Fire reaction	Euroclass	E			EN ISO 11925-2
Limit of operating temperature		70		°C	
Declaration according to UNI EN 13163	T1-L3-W2-S2-P5-BS200-CS(10)150-DS(70,-)1-WL(T)3-MU(30-70)				



Blank panel

This neutral panel is made of polystyrene, thickness 27 mm, and it is used to finish the areas not fitted with thermally active panels.

Panel features

SIZE	WEIGHT	CODE
2200x600x27 mm	1.1 Kg	6100700



Pipe insulation for Ø 6 mm pipe

Closed-cell elastomeric foam insulating sleeve, smooth on the surface, for thermal insulation of PB Ø 6 mm pipe. Thickness 6 mm.

SIZE	CODE
Ø 6 mm	6320010



RDZ Retard 180 m

Retarder for gypsum plaster applications and bonding agents. Dosage: 0.5% of the water necessary to dilute the bonding agent (100 g in 20 L of water or 1 can every 50 m²). Useful for traditional b!klimax panels.

SIZE	CODE
1 liter	6602000



Screw and Washer

55-mm screws and washers made of stainless steel. They are used to fix b!klimax panels to the metal grid.

SIZE	CODE
55 mm	6510005

THERMAL OUTPUT OF THE SYSTEM

Thermal output in heating - ceiling

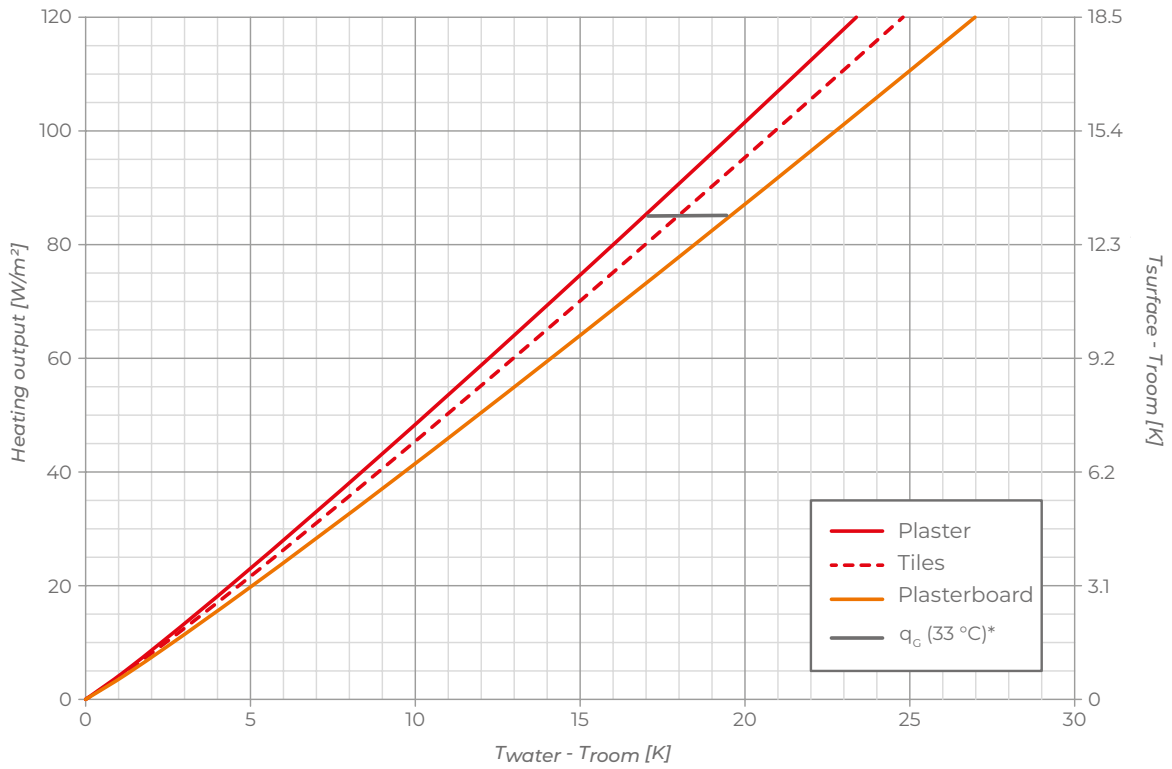

Thermal output in heating - wall

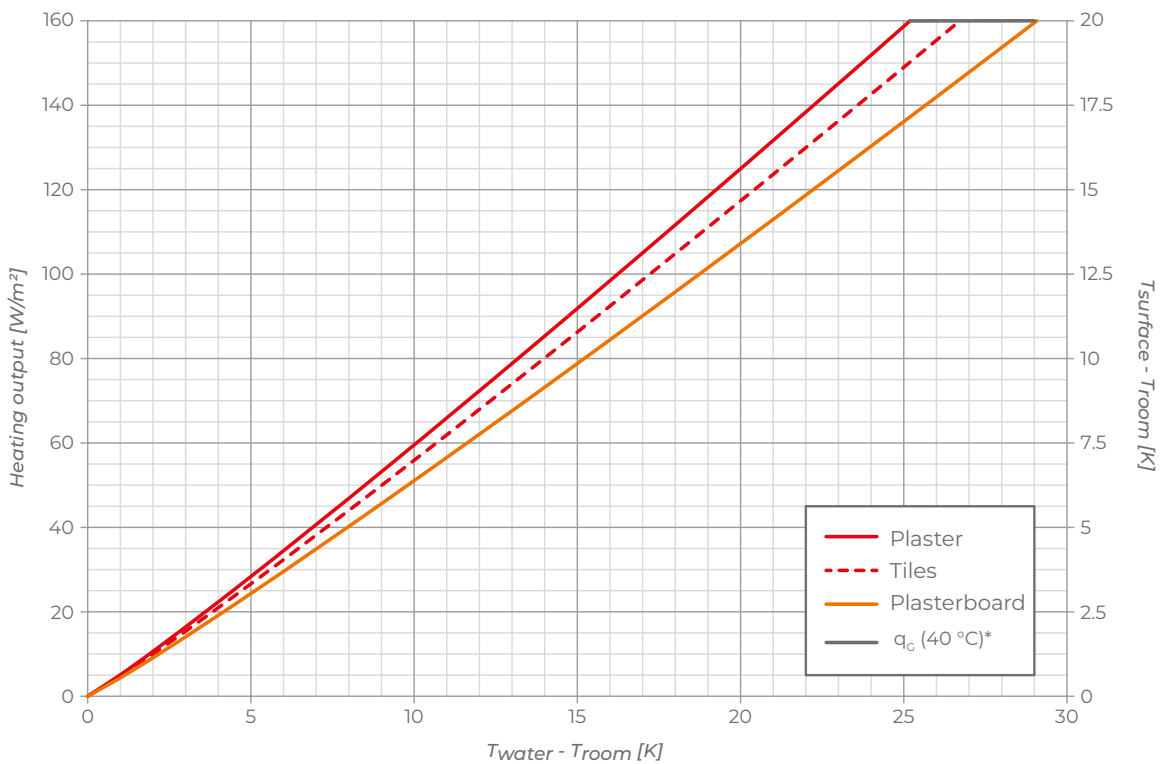

q_c : limit output
 *valid only for room temperature= 20 °C

Thermal output in cooling - ceiling

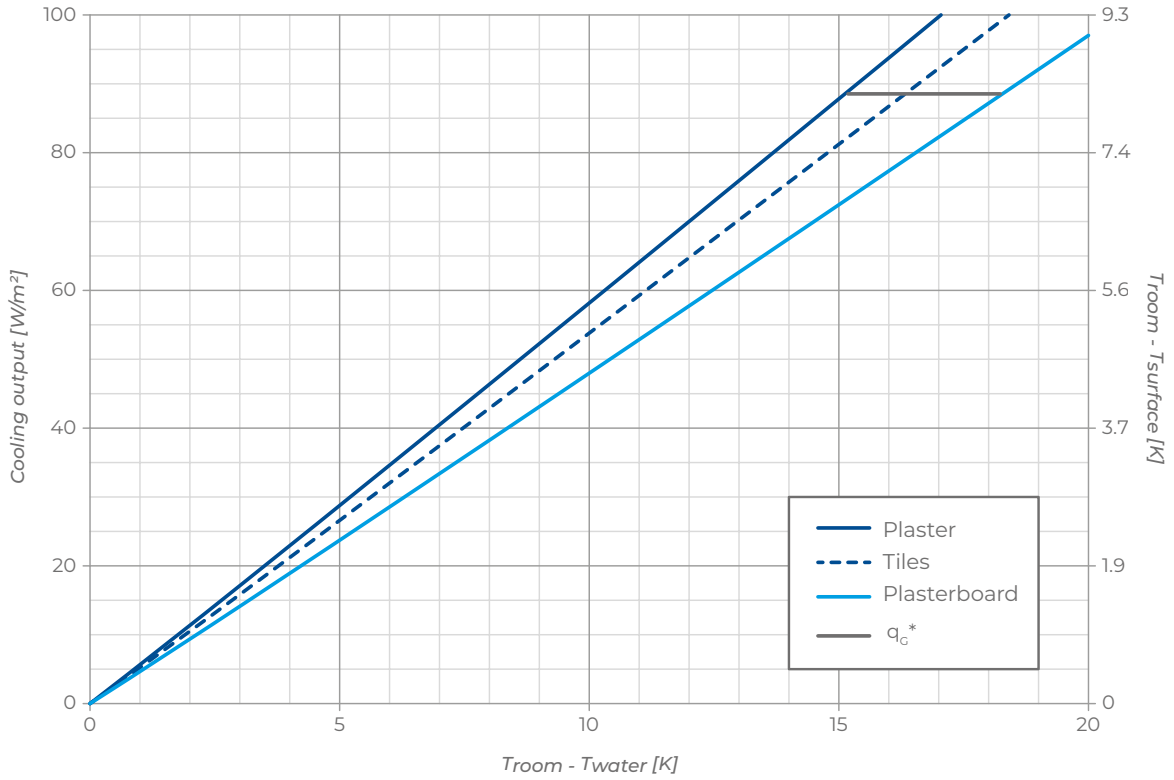

Thermal output in cooling - wall

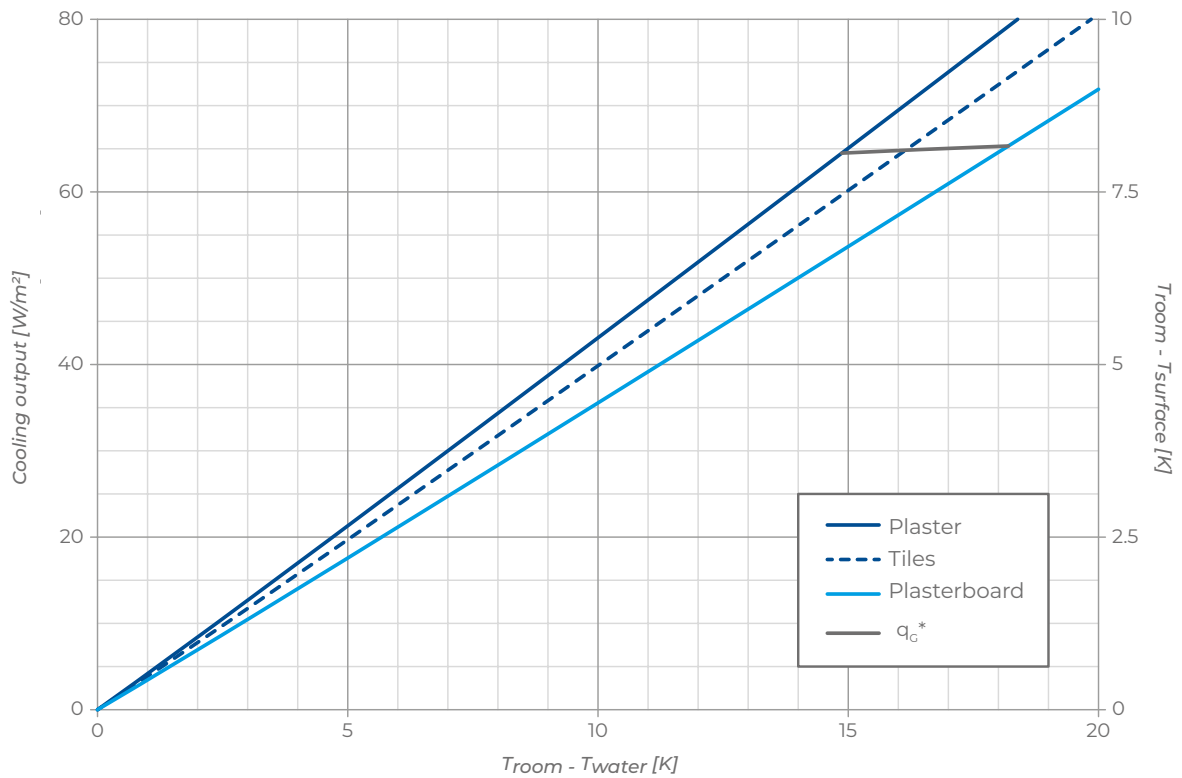

q_c : limit output
 *valid only for room temperature= 26 °C 55% R.H.



b!klimax Air+ is a room heating and cooling system that uses ceilings and walls as radiant surfaces. Invisible, comfortable and healthy, it provides the ideal room climate along with cleaner, healthier air.

The central element of the system is the polystyrene or rockwool radiant panel equipped with 4 hydraulic circuits \varnothing 6 mm and complete with a special plasterboard sheet capable of capturing and neutralising indoor pollutants.

The system is completed by the manifold, the distributors, the fittings, the \varnothing 20 mm polybutylene pre-insulated pipe for connecting the distributors to the manifold and the \varnothing 6 mm polybutylene pre-insulated pipe for connecting the panels to the distributors.

Designed to be installed on common metal structures for false ceilings, b!klimax Air+ does not require any invasive intervention and allows to exploit the gap between the ceiling and the radiant panels for the installation of other systems.

FEATURES

- Minimum recommended installation height 12 cm
- Ceiling or wall installation
- Low thermal inertia
- Finishing with special plasterboard sheet capable of reducing the concentration of indoor pollutants
- Installation on metal structure with 30 cm wheelbase
- Insulation in polystyrene or rockwool
- Suitable for residential and commercial application (schools, offices, hotels, hospitals, public buildings,...)



SECTION OF THE SYSTEM

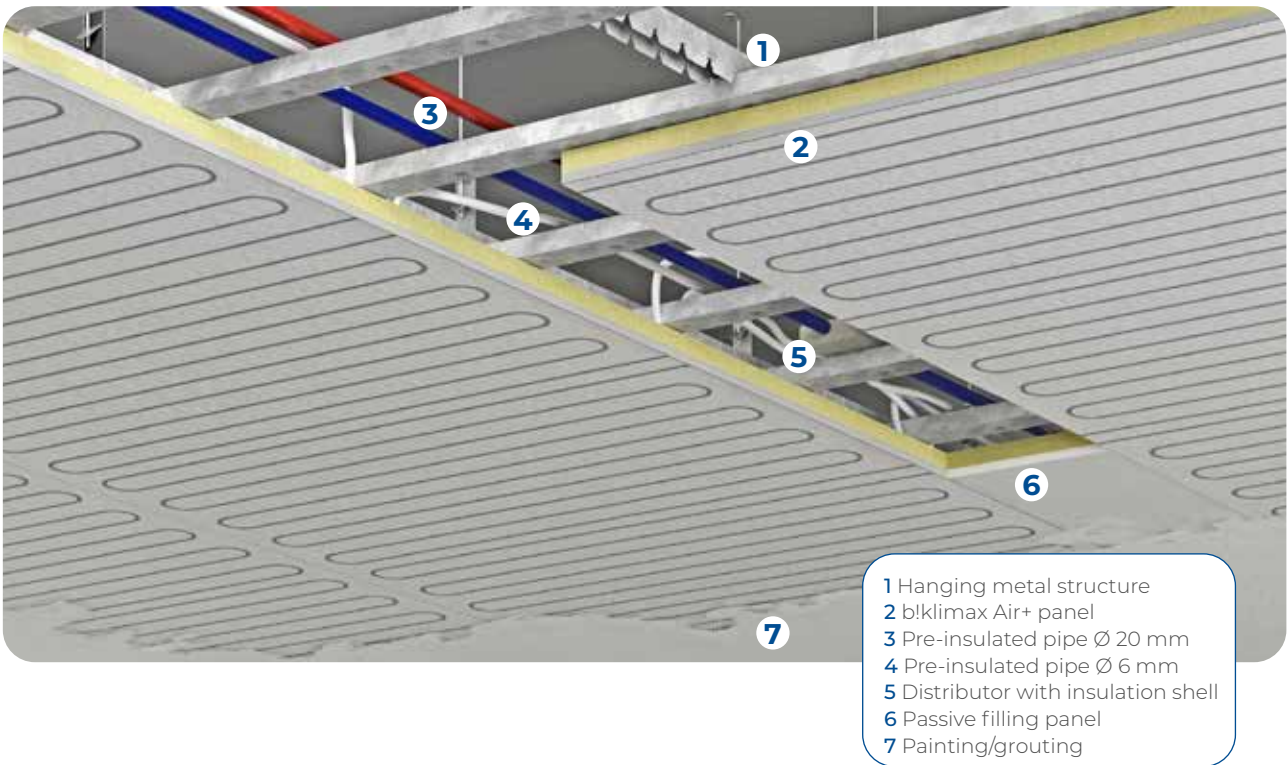

METAL SUPPORT STRUCTURE

b!klimax Air+ radiant panels are designed to be installed both on walls and ceilings on common double metal frame structures for dry systems, available on the market. Depending on the height of the rooms, it is possible to modulate the height of the pendant hooks according to specific requirements (aesthetic, based on the need to pass the ducts for other systems, etc.).

Hanging structure with snap profile

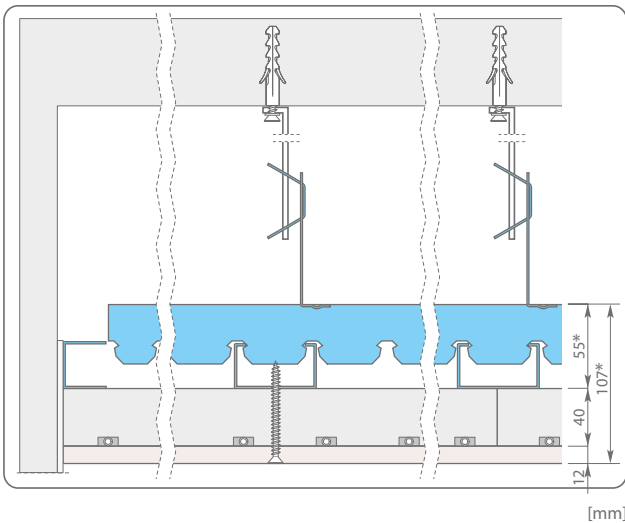

Structure with snap profile

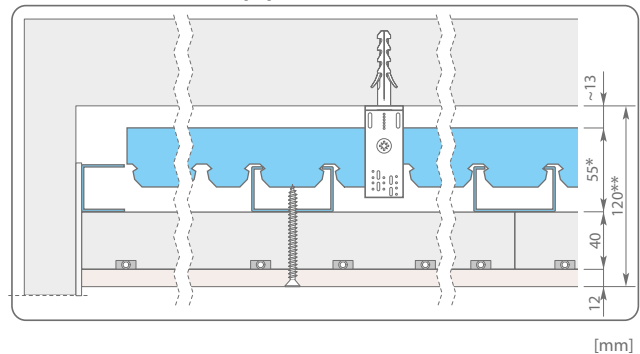

* Variable dimension depending on the profile used.

** If possible, to facilitate installation, we suggest a minimum height of 150 mm.

PRODUCTS THAT COMPOSE THE SYSTEM

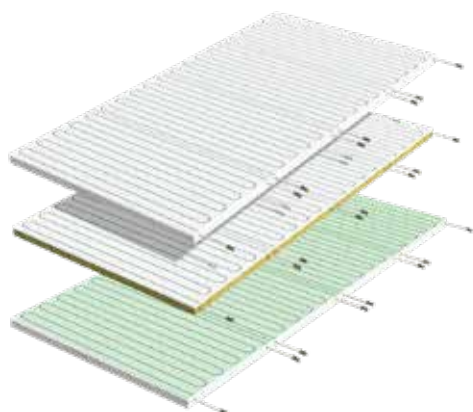

Panel features

Dimensions: 1200x2400x52 mm

INSULATION	WEIGHT	CODE
Polystyrene	35.8 Kg	6143114
Polystyrene (waterproof)	29.8 Kg	6143100
Rockwool	47.6 Kg	6143115

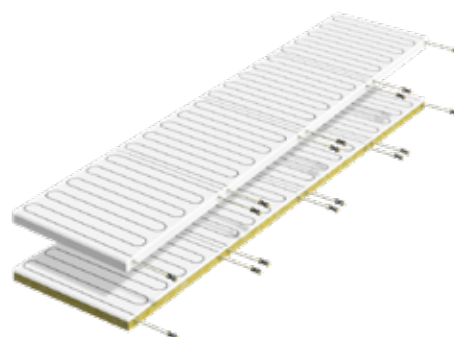

Panel features

Dimensions: 600x2400x52 mm

INSULATION	WEIGHT	CODE
Polystyrene	17.9 Kg	6143169
Rockwool	27.1 Kg	6143170

b!klimax Air+ panel

This radiant panel consists in extra white plasterboard which is able to absorb indoor pollutants. The panel includes 4 hydraulic circuits, made of pipe Ø 6 mm, provided with push-fit fittings and oxygen barrier according to DIN 4726. Pipes are fixed to the panel through an aluminium metal diffuser. Available with polystyrene and rockwool (fire reaction class: A1) insulation.

Plasterboard sheet characteristics	600	1200	Unit	Standard
Size	600x2400	1200x2400	mm	
Standard thickness	12.5		mm	
Density	870		Kg/m ³	
Fire reaction	A2-s1,d0			
Thermal conductivity	0.21		W/(m·K)	
Water vapour diffusion	(dry) 10	4	μ	EN 10456
	(humid)			

Polystyrene insulation characteristics	600	1200	Unit	Standard
Size of insulating panel	600x2400	1200x2400	mm	UNI EN 822
Standard thickness	40		mm	UNI EN 823
Insulation base thickness	34		mm	UNI EN 1264-3
Bending strength	BS	170	kPa	UNI EN 12089
Compressive stress at 10% deformation	CS(10)	120	kPa	UNI EN 826
Thermal conductivity 10 °C	λd	0.035	W/(m·K)	UNI EN 12667
Thermal resistance	Rd	1.10	(m ² ·K)/W	UNI EN 12667
Thermal transmittance	U	0.90	W/(m ² ·K)	
Water vapour diffusion resistance factor	μ	30 ÷ 70		UNI EN 12086
Water vapour permeability	δ	0.009 ÷ 0.020	mg/(Pa·h·m)	UNI EN 12086
Dimensional stability at 48h and 70 °C	DS(70,-)	1	%	UNI EN 1604
Long term water absorption by partial immersion	Wlp	0.5	Kg/m ²	UNI EN 12087
Long term water absorption by total immersion	WI(T)	≤3	%	UNI EN 12087
Fire reaction	Euroclass	E		EN ISO 11925-2
Limit of operating temperature		70	°C	
Declaration according to UNI EN 13163	T1-L3-W2-S2-P5-BS170-CS(10)120-DS(70,-)1-WL(T)3-MU(30-70)			

Rockwool insulation characteristics		600	1200	Unit	Standard
Size of insulating panel		600x2400	1200x2400	mm	UNI 822
Standard thickness		40		mm	UNI 823
Declared thermal conductivity	λ_d	0.040		W/(m·K)	UNI EN 12667, 12939
Thermal resistance	R _d	1		(m ² ·K)/W	
Resistance to compression 10%	σ_{10}	70		kPa	UNI EN 826
Resistance to point load	F _p	600		N	UNI EN 12430
Tensile bond strength	σ_{mt}	15		kPa	UNI EN 1607
Water vapour diffusion resistance factor	μ	1			UNI EN 12086
Short term water absorption by partial immersion	W _s	< 1		kg/m ²	EN 1609
Long term water absorption by immersion	W _{l(p)}	< 3		kg/m ²	EN 12087
Specific heat	C _p	1030		J/(KgK)	UNI EN 10456
Density	ρ	165		Kg/m ³	UNI EN 1602
Fire reaction	Euroclass	A1			UNI EN 13501-1
Declaration according to UNI EN 13162		MW-EN 13162 T5-CS(10/Y)70-PL(5)600-TR15-DS(TH)-DS(T+)-MUI-WS-WL(p)			

Air+ blank panel

Blank panel made of extra white plasterboard which is able to absorb indoor pollutants. This panel is used to fill the area which is not covered with radiant panels and the area where distributors are installed. It can be cut according to the actual requirements.

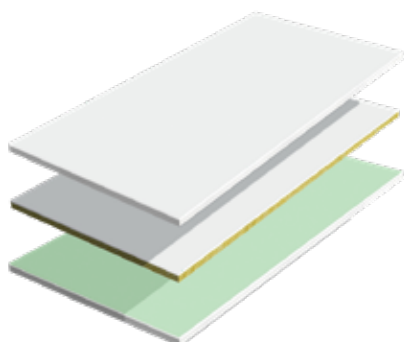

Panel features

Dimensions: 1200x2400x52 mm

INSULATION	WEIGHT	CODE
Polystyrene	34.5 Kg	6143124
Polystyrene (waterproof)	28.2 Kg	6143105
Rockwool	53.5 Kg	6143125

70-mm Fixing Screws

70-mm screws to fix b!klimax+ panels with plasterboard to the metal grid.



SIZE	CODE
70 mm	6510010

■ THERMAL OUTPUT OF THE SYSTEM

Thermal output in heating - ceiling

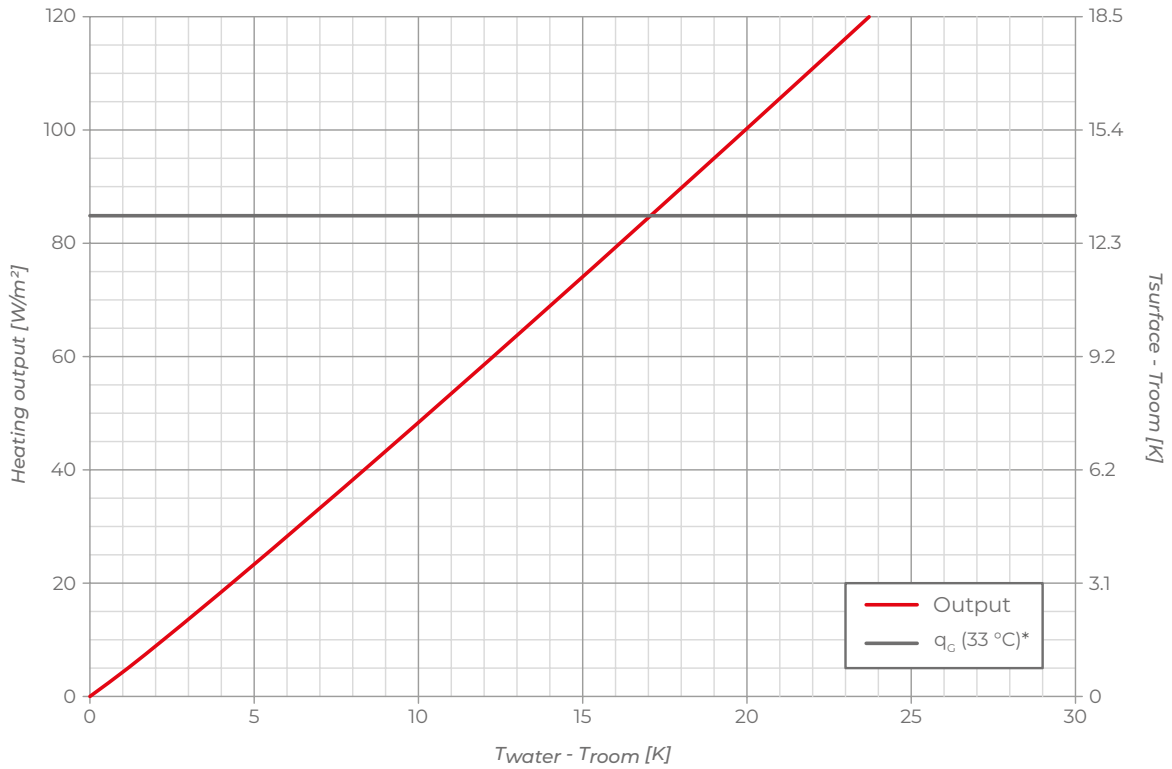

Thermal output in heating - wall

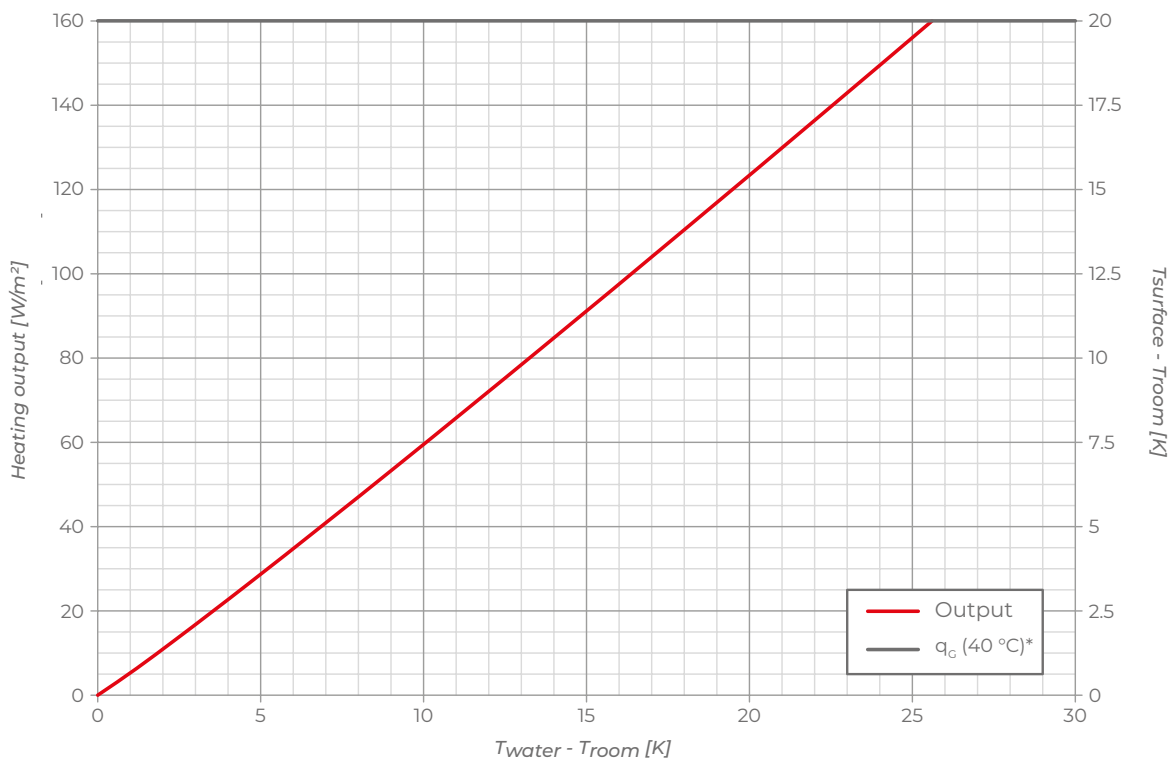

q_c : limit output

*valid only for room temperature= 20 °C

Thermal output in cooling - ceiling

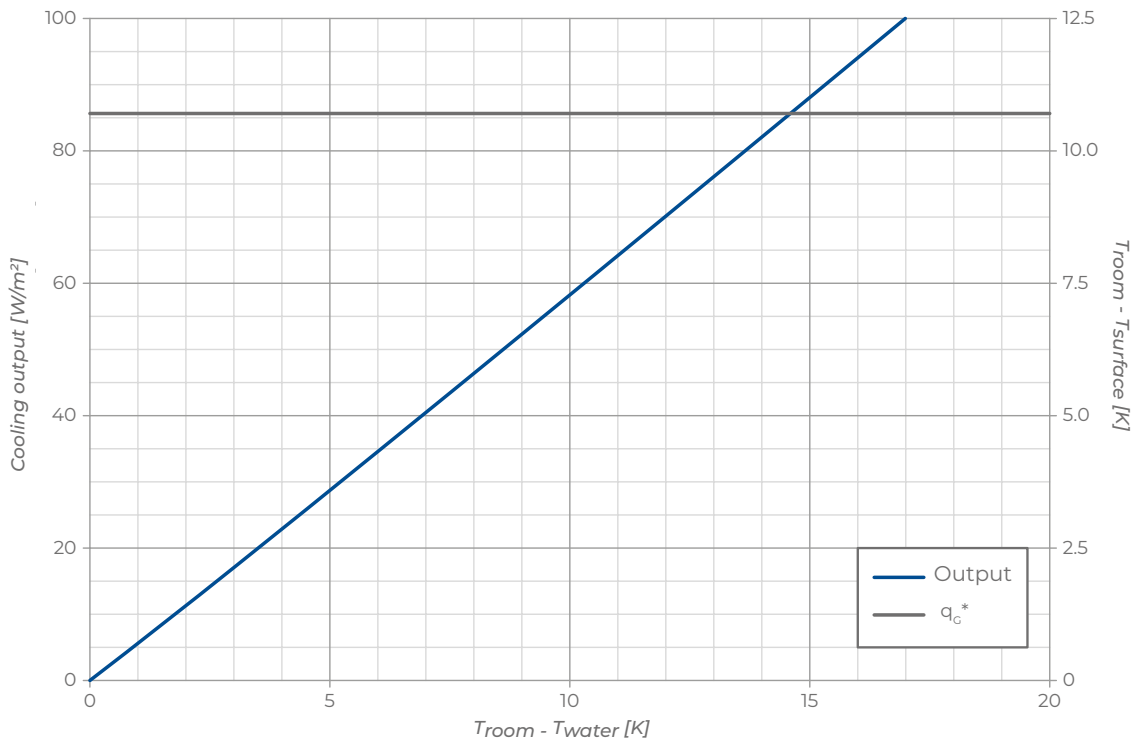

Thermal output in cooling - wall

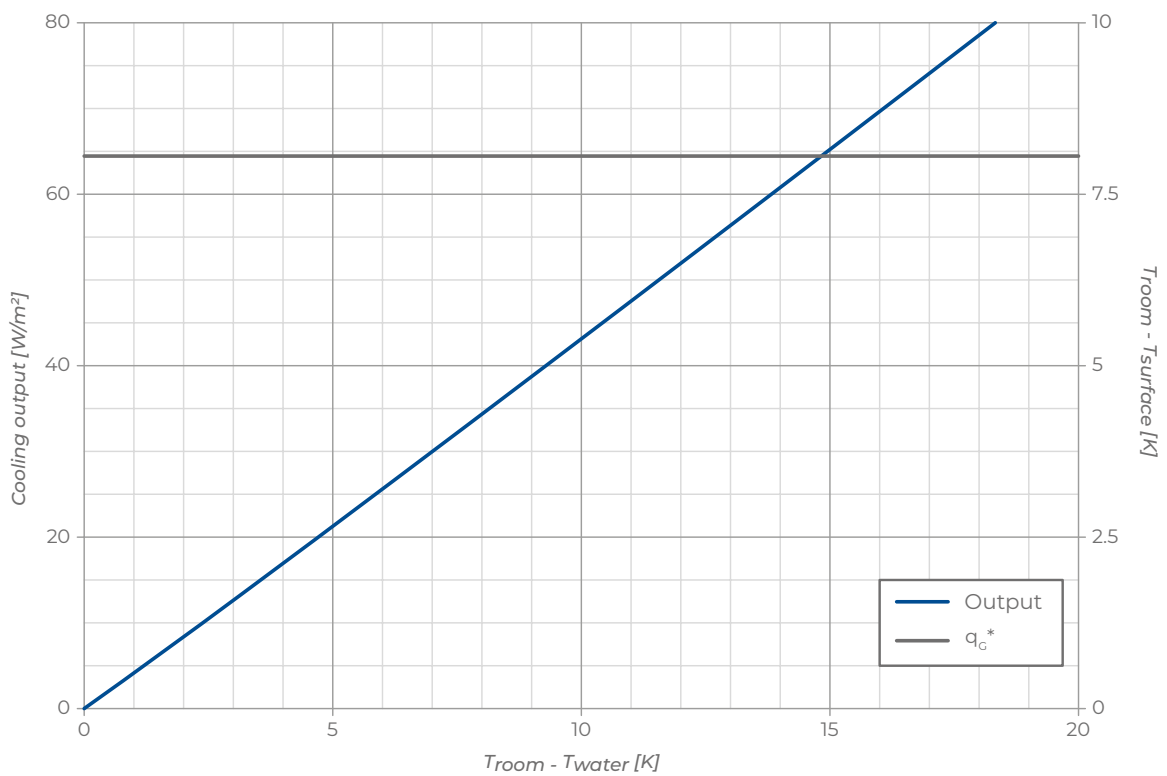

q_c : limit output
 *valid only for room temperature= 26 °C 55% R.H.

COMPLEMENTS FOR SYSTEMS WITH Ø 6 PIPE



Pre-insulated pipe Ø 20 mm

PB pipe with oxygen barrier according to DIN 4726 EN 12319-2, Ø 20 mm, pipe insulation made of expanded polyethylene, thickness 6 mm. Reaction to fire class: BL-s2, d0. It is used to connect distributors with b!klimax manifolds.

TYPE	SIZE	CODE
red roll 50 m	Ø 20 mm	6200020
blu roll 50 m	Ø 20 mm	6201020

Note:
for further technical data see page 56



8-way Distributors

Pair of distributors made of plastic, specially shaped to guarantee easy connection with the pipes coming from b!klimax panels. These distributors are provided with anticondensation shells made of polystyrene or expanded polyethylene BL-s1,d0, push-fit pipe fittings for pipes Ø 6 mm and Ø 20 mm, and closing plastic bands.

MODEL	INSULATION	CODE
8-way open	polystyrene	6210040
8-way open	polyethylene	6210041
8-way terminal	polystyrene	6210050
8-way terminal	polyethylene	6210051



4-way Distributors

Pair of distributors made of plastic, specially shaped to guarantee easy connection with the pipes coming from b!klimax panels. These distributors are provided with anticondensation shells made of polystyrene or expanded polyethylene BL-s1, d0, push-fit pipe fittings for pipes Ø 6 mm and Ø 20 mm, and closing plastic bands.

MODEL	INSULATION	CODE
4-way open	polystyrene	6210060
4-way open	polyethylene	6210061
4-way terminal	polystyrene	6210070
4-way terminal	polyethylene	6210071



Straight Push-fit Fitting Ø 6 mm

Straight push-fit fitting used as connection for polybutylene pipes Ø 6 mm or Ø 20 mm. It's provided with anticondensation insulation shells available in polystyrene or polyethylene BL-s1, d0.

SIZE	INSULATION	CODE
Ø 6 mm	polystyrene	6510006
Ø 6 mm	polyethylene	6510016
Ø 20 mm	polyethylene	6510026



TEE Push-fit Fitting 20-20-20 mm

TEE push-fit fitting used as connection for PB pipes Ø 20 mm. It's provided with anticondensation insulation shells available in polystyrene or polyethylene BL-s1, d0.

SIZE	INSULATION	CODE
Ø 20 mm	polystyrene	6510055
Ø 20 mm	polyethylene	6510056



Cross Push-fit Fitting 20-20-20-20 mm

This cross push-fit fitting is used as connection for polybutylene pipes Ø 20 mm. It's provided with anticondensation insulation shells available in polystyrene or polyethylene BL-s1, d0.

SIZE	INSULATION	CODE
Ø 20 mm	polystyrene	6510065
Ø 20 mm	polyethylene	6510066



Elbow Push-fit Fitting 20-20 mm

This ELBOW push-fit fitting is used as 90° shifting for polybutylene pipes Ø 20 mm. It's provided with polyethylene BL-s1, d0 insulation or without it.

SIZE	INSULATION	CODE
Ø 20 mm	--	6510075
Ø 20 mm	polyethylene	6510076



Pre-insulated PB Pipe Ø 6 mm

PB pipe Ø 6 mm with oxygen barrier according to DIN 4726 EN 12319-2, pipe insulation made of expanded polyethylene, reaction to fire class BL-s1, d0, thickness 6 mm. It is used to connect b!klimax+ and Quadrotto panels to the distributors.

SIZE	CODE
Ø 6 mm	6210006

Note:
for further technical data see page 57



Lubricant for Push-fit Pipe Fittings

This lubricant is used to guarantee better insertion of the pipes into the fittings and better preservation of O-rings. (1 package every 75 circuits).

SIZE	CODE
20 ml	6603000



Closing Plugs for Outlets Ø 6 mm and Ø 20 mm

Plastic plugs are used to close the unused outlets in a distributor.

SIZE	CODE
Ø 6 mm	6510040
Ø 20 mm	6510050



Industry System Elbow

Elbow for 90° shifting with pipes Ø 20 mm.

SIZE	CODE
Ø 20 mm	1140025



b!klimax Perimeter belt

Edge insulation for b!klimax and b!klimax+ ceiling systems, made of closed-cell expanded polyethylene. It acts as thermo-acoustic insulation and it absorbs plasterboard ceiling expansions.

SIZE	CODE
h 150 mm	6603010



Spare parts kit

Replacement kit for b!klimax fittings and distributors including all the components needed to restore a pipe connection.

SIZE	CODE
for Ø 6 mm pipe	6510070
for Ø 20 mm pipe	6510080

B!KLIMAX 8+ SYSTEM WITH PLASTERBOARD



b!klimax 8+ is a room heating and cooling system that uses ceilings and walls as radiant surfaces. Invisible and efficient, it guarantees uniform temperature distribution and high thermal comfort in every room. The use of \varnothing 8 mm pipe also means that there are fewer circuits and therefore fewer components, speeding up installation operations.

Designed to be installed on common metal structures for false ceilings, it does not require invasive interventions and allows to exploit the gap between the ceiling and the radiant panels for the installation of other systems.

The central element of the system is the panel consisting of a plasterboard sheet onto which, by an aluminium metal diffuser, 2 hydraulic circuits in PE-RT \varnothing 8 mm pipe are fixed. The panel is available with polystyrene or rockwool insulation.

The system is completed by the manifold, the distributors, the fittings, the \varnothing 20 mm polybutylene pre-insulated pipe for connecting the distributors to the manifold and the \varnothing 8 mm PE-RT pipe with insulation for connecting the panels to the distributors.

FEATURES

- Minimum recommended installation height 12 cm
- Ceiling or wall installation
- Low thermal inertia
- Installation on metal structure with 30 cm spacing
- Insulation in polystyrene or rockwool
- Particularly suitable for renovation
- Suitable for residential and commercial applications
- Quick installation thanks to the reduced number of components



SECTION OF THE SYSTEM



- 1 Hanging metal structure
- 2 Distributor with insulation shell
- 3 Pre-insulated pipe Ø 20 mm
- 4 Pre-insulated pipe Ø 8 mm
- 5 b!klimax 8+ panel
- 6 Passive filling panel
- 7 Painting/grouting

METAL SUPPORT STRUCTURE

b!klimax 8+ radiant panels are designed to be installed both on walls and ceilings on common double metal frame structures for dry systems available on the market. Depending on the height of the rooms, it is possible to modulate the height of the pendant hooks according to specific requirements (aesthetic, based on the need to pass the ducts for other systems, etc.).

Hanging structure with snap profile

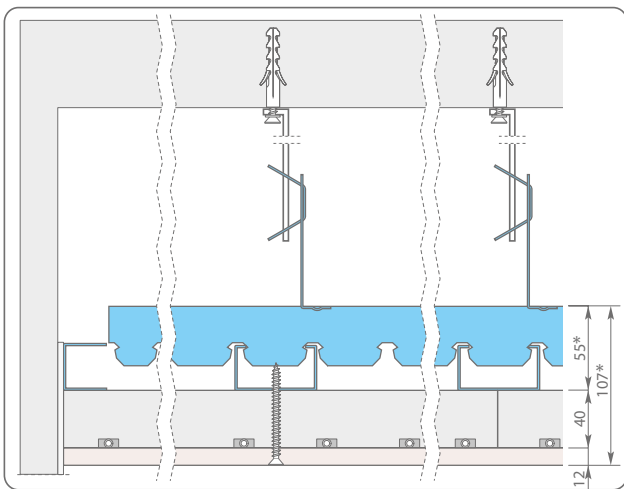

[mm]

Structure with snap profile

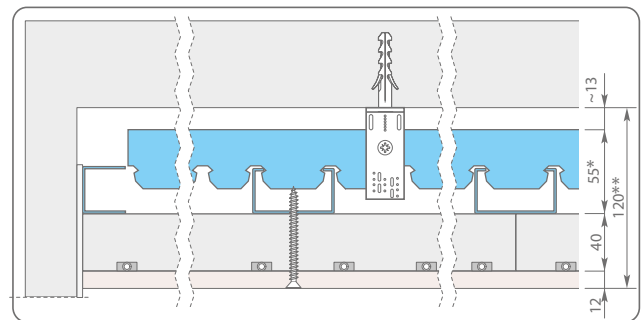

[mm]

* Variable dimension depending on the profile used.

** If possible, to facilitate installation, we suggest a minimum height of 150 mm.

PRODUCTS THAT COMPOSE THE SYSTEM

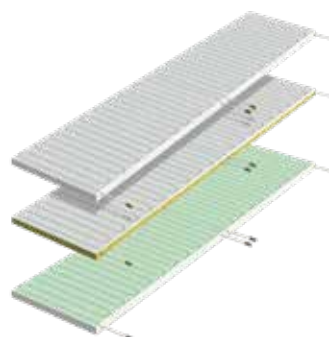
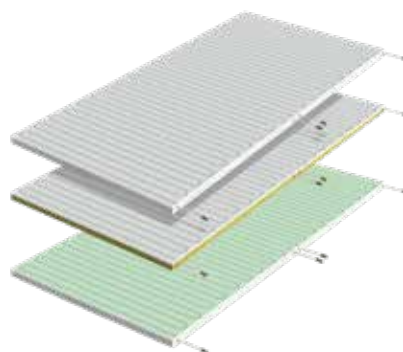

Panel features

Dimensions: 1200x2400x52 mm

INSULATION	WEIGHT	CODE
Polystyrene	29.5 Kg	6142115
Rockwool	47.9 Kg	6142210
Polystyrene (waterproof)	30.2 Kg	6143101

Panel features

Dimensions: 600x2400x52 mm

INSULATION	WEIGHT	CODE
Polystyrene	14.9 Kg	6142170
Rockwool	24.1 Kg	6142270
Polystyrene (waterproof)	15.4 Kg	6143161

b!klimax 8+ panel with plasterboard

b!klimax 8+ radiant panels are made up of 12.5-mm thick plasterboard of 2.88 m². On the plasterboard is printed the position of the hydraulic circuits, made of PE-RT pipe Ø 8 mm and embedded in the panel, provided with push-fit fittings and oxygen barrier according to DIN 4726. Pipes are fixed to the panel through an aluminium metal diffuser. Available with different insulation types.

Plasterboard characteristics	600	1200	Unit	Standard
Size	600x2400	1200x2400	mm	
Standard thickness	12.5		mm	
Density	760		Kg/m ³	
Fire reaction	A2-s1,d0			
Thermal conductivity	0.20		W/(m·K)	
Water vapour diffusion resistance factor	10		μ	EN 10456

Polystyrene insulation characteristics	600	1200	Unit	Standard
Size of insulating panel	600x2400	1200x2400	mm	UNI EN 822
Standard thickness	40		mm	UNI EN 823
Insulation base thickness	34		mm	UNI EN 1264-3
Bending strength	BS	170	kPa	UNI EN 12089
Compressive stress at 10% deformation	CS(10)	120	kPa	UNI EN 826
Thermal conductivity 10 °C	λd	0.035	W/(m·K)	UNI EN 12667
Thermal resistance	Rd	1.10	(m ² ·K)/W	UNI EN 12667
Thermal transmittance	U	0.90	W/(m ² ·K)	
Water vapour diffusion resistance factor	μ	30 ÷ 70		UNI EN 12086
Water vapour permeability	δ	0.009 ÷ 0.020	mg/(Pa·h·m)	UNI EN 12086
Dimensional stability at 48h and 70 °C	DS(70,-)	1	%	UNI EN 1604
Long term water absorption by partial immersion	Wlp	0.5	Kg/m ²	UNI EN 12087
Long term water absorption by total immersion	WI(T)	≤3	%	UNI EN 12087
Fire reaction	Euroclass	E		EN ISO 11925-2
Limit of operating temperature		70	°C	
Declaration according to UNI EN 13163	T1-L3-W2-S2-P5-BS170-CS(10)120-DS(70,-)1-WL(T)3-MU(30-70)			

Rockwool insulation characteristics		600	1200	Unit	Standard
Size of insulating panel		600x2400	1200x2400	mm	UNI 822
Standard thickness:		40		mm	UNI 823
Declared thermal conductivity	λ_d	0.040		W/(m·K)	UNI EN 12667, 12939
Thermal resistance	R_d	1		(m ² ·K)/W	
Resistance to compression 10%	σ_{10}	70		kPa	UNI EN 826
Resistance to point load	F_p	600		N	UNI EN 12430
Tensile bond strength	σ_{mt}	15		kPa	UNI EN 1607
Water vapour diffusion resistance factor	μ	1			UNI EN 12086
Short term water absorption by partial immersion	W_s	< 1		kg/m ²	EN 1609
Long term water absorption by immersion	$W_l(p)$	< 3		kg/m ²	EN 12087
Specific heat	C_p	1030		J/(KgK)	UNI EN 10456
Density	ρ	165		Kg/m ³	UNI EN 1602
Fire reaction	Euroclas.	A1			UNI EN 13501-1
Declaration according to UNI EN 13162		MW-EN 13162 T5-CS(10/Y)70-PL(5)600-TR15-DS(TH)-DS(T+)-MUT-WS-WL(p)			

Waterproof insulation characteristics		600	1200	U.M.	Norma
Dimensiones del panel aislante		600x2400	1200x2400	mm	UNI EN 520
Espesor nominal		12.5		mm	UNI EN 520
Peso		8.5		kg/m ²	
Clase de reacción al fuego - EN13501-1		A2-s1, d0		W/(m·K)	UNI EN 520
Conducibilidad térmica		0.20		kPa	UNI EN 12664
Absorción de agua tras 2 horas de inmersión		600		N	UNI EN 520
Factor de resistencia a la difusión del vapor de agua		15		kPa	UNI EN ISO 10456

PE-RT pipe characteristics						
Application field		CLASS 4	For use with hot and cold water		T _{max} 70 °C	Pressure 8 bar
		CLASS 5	For use with hot and cold water		T _{max} 90 °C	Pressure 6 bar
Outside diam. (mm)	Thickness (mm)	Circuit Length (mm)		Weight (g/m)	Water content (l/m)	
8	1	600	1200	22	0,028	
		12	24			

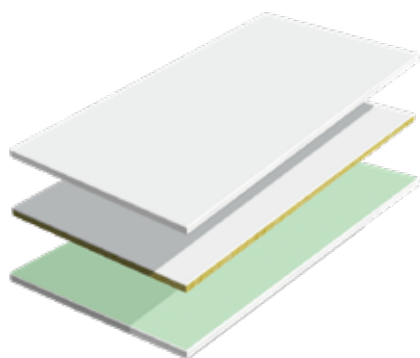

Blank panel

Passive panel consisting of standard or waterproof plasterboard, without hydraulic circuits and available with polystyrene or rockwool (fire reaction class: A1) insulation. Necessary for filling areas not covered by radiant panels and areas where distributors are housed.

Panel features 1200x2400x52 mm

INSULATION	WEIGHT	CODE
Polystyrene	27.8 Kg	6142105
Rockwool	46.9 Kg	6142205
Waterproof	29.8 Kg	6143105



70-mm Fixing Screws

70-mm screws to fix b!klimax+ panels with plasterboard to the metal grid.

SIZE	CODE
70 mm	6510010

■ THERMAL OUTPUT OF THE SYSTEM

Thermal output in heating - ceiling

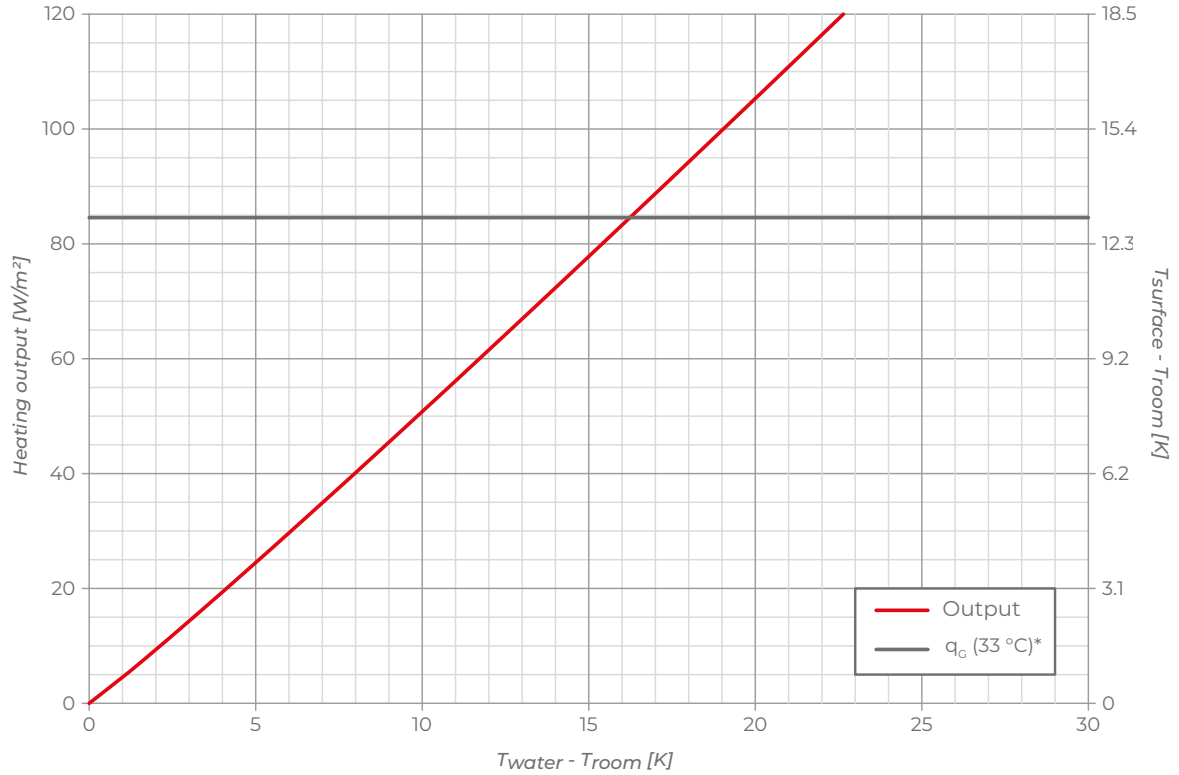

Thermal output in heating - wall

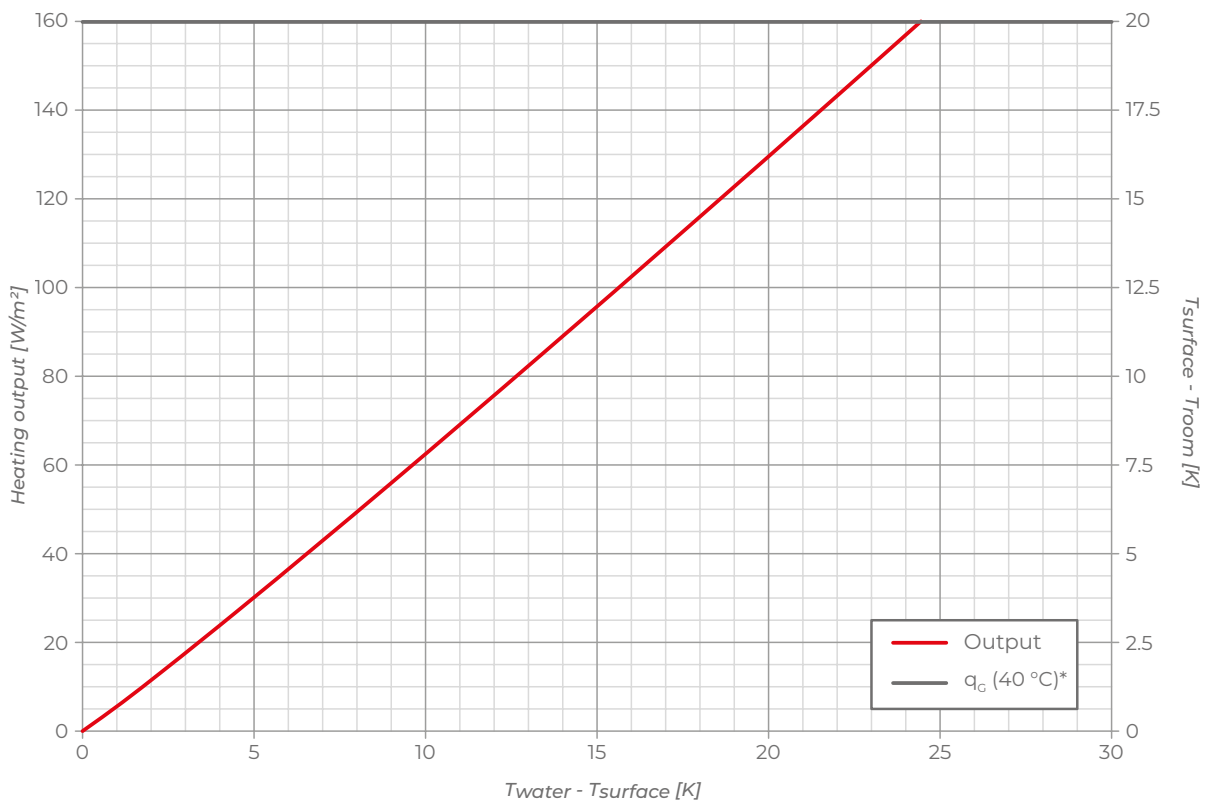

q_c : limit output

*valid only for room temperature= 20 °C

Thermal output in cooling - ceiling

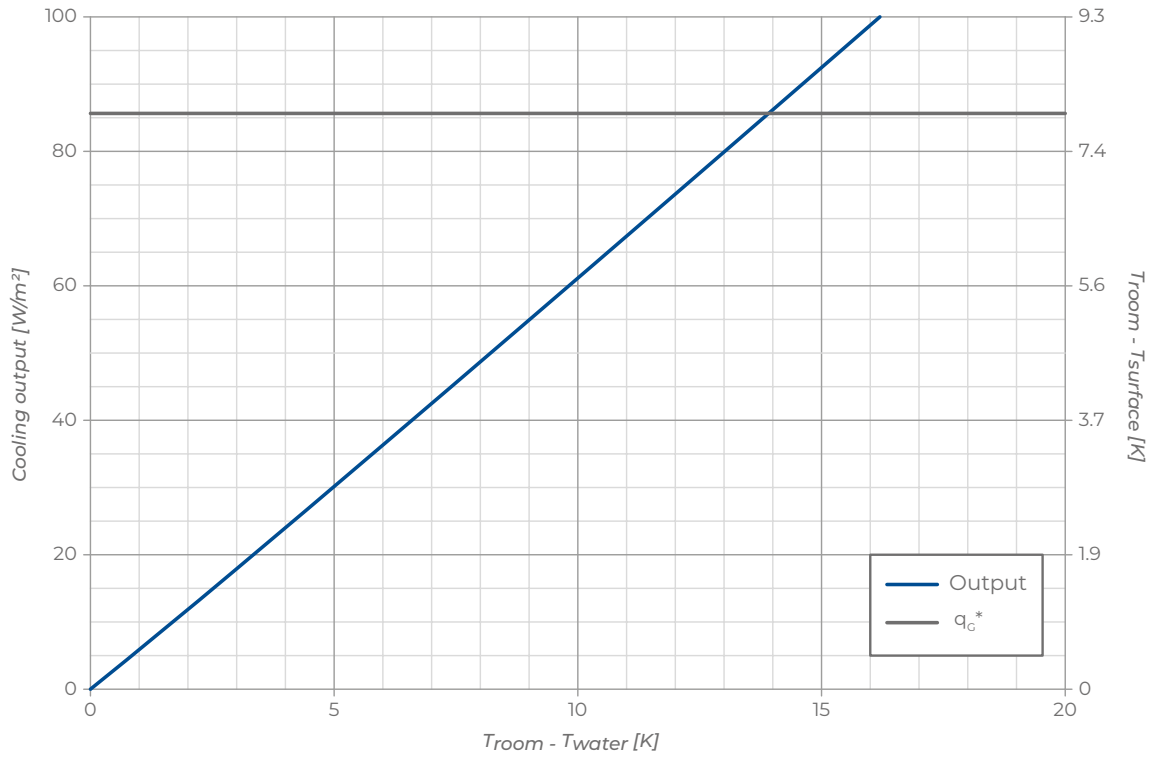

Thermal output in cooling - wall

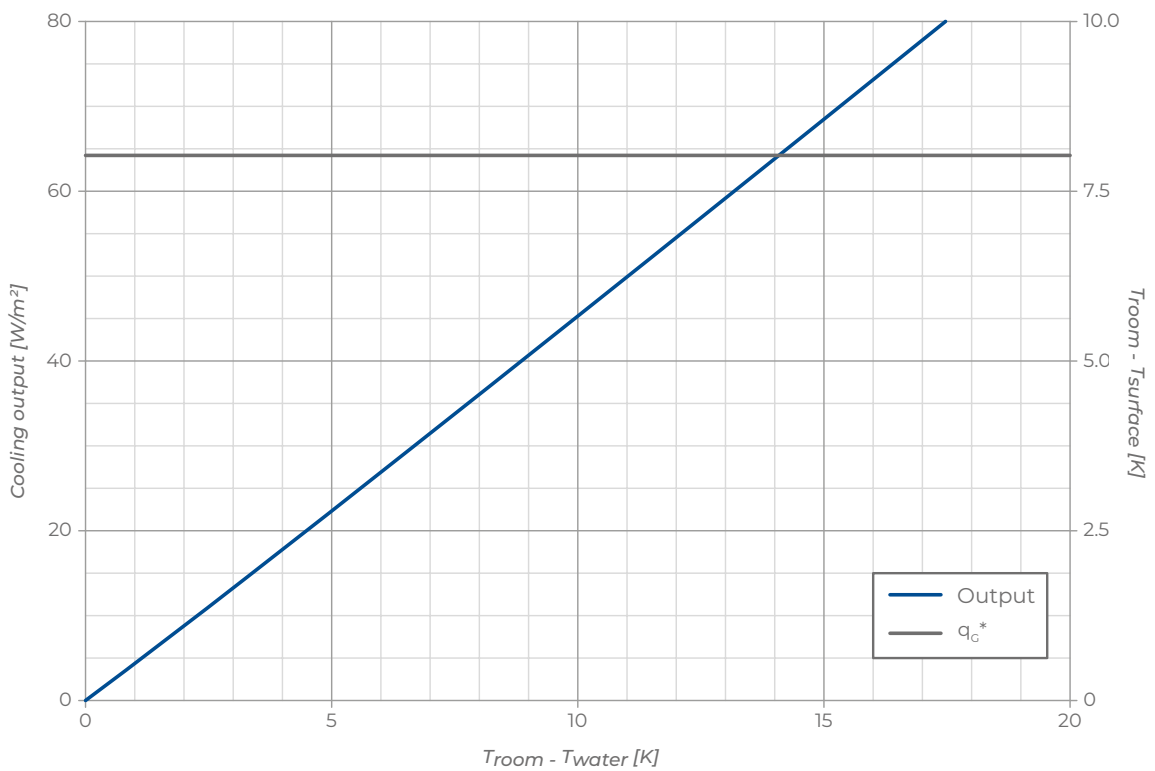

q_c^* : limit output
 *valid only for room temperature= 26 °C 55% R.H.



B!klimax 8+ HP is a heating and cooling system that uses ceilings and walls as radiant surfaces. Invisible and efficient, it ensures uniform temperature distribution and a high level of indoor comfort. Thanks to the surface finish consisting of a plasterboard slab admixed with graphite, this system is able to guarantee high thermal performances. The use of $\varnothing 8$ piping means that fewer circuits and components are required, which makes laying quicker.

Designed for being installed on common metal structures for suspended ceilings, b!klimax 8+ HP does not require invasive works and allows for exploiting the gap between the radiant ceiling and the ceiling slab for concealing other systems.

The central element is the radiant panel with high thermal output: it consists of a plasterboard and graphite slab fitted, by means of an aluminium diffuser, with 2 PE-RT $\varnothing 8$ mm hydraulic circuits. The entire assembly is thermally insulated thanks to a layer of shaped polystyrene which houses the piping.

The system is completed by a manifold, distributors, fittings, a $\varnothing 20$ mm pre-insulated polybutylene pipe connecting the distributors to the manifold, and an $\varnothing 8$ mm PE-RT pipe connecting the panels to the distributors.

CHARACTERISTICS

- Minimum recommended lowering: 12 mm
- Wall- or ceiling-mounted installation
- Low thermal inertia
- High thermal performances thanks to the slab with graphite
- Installation on metal structure with 30 mm centre-to-centre distance
- Highly recommended for renovation works
- Suitable for residential and tertiary-sector environments
- Quick installation thanks to the low number of components



SECTION OF THE SYSTEM

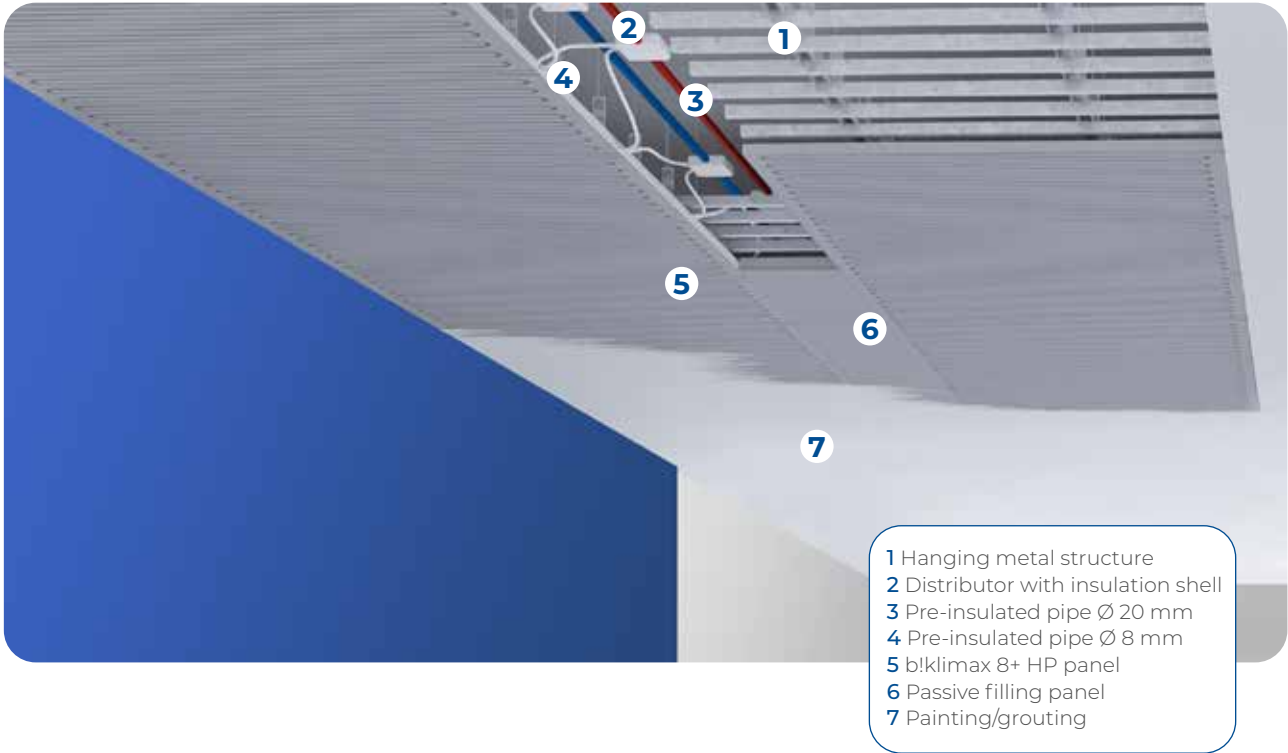

METAL SUPPORT STRUCTURE

b!klimax 8+ HP radiant panels are designed to be installed both on walls and ceilings on common double metal frame structures for dry systems available on the market. Depending on the height of the rooms, it is possible to modulate the height of the pendant hooks according to specific requirements (aesthetic, based on the need to pass the ducts for other systems, etc.).

Hanging structure with snap profile

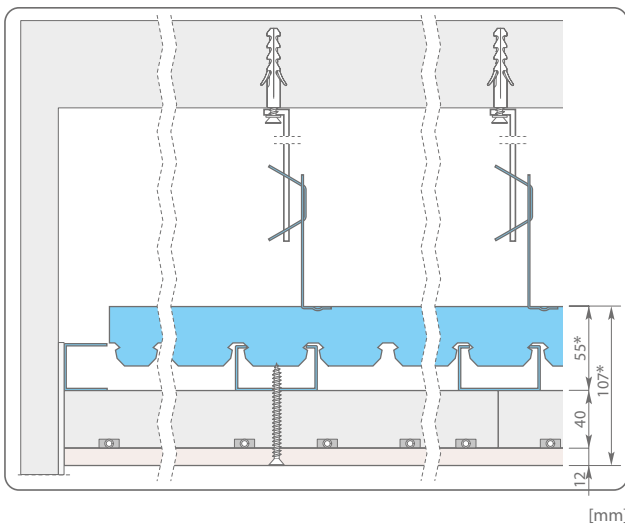

Structure with snap profile

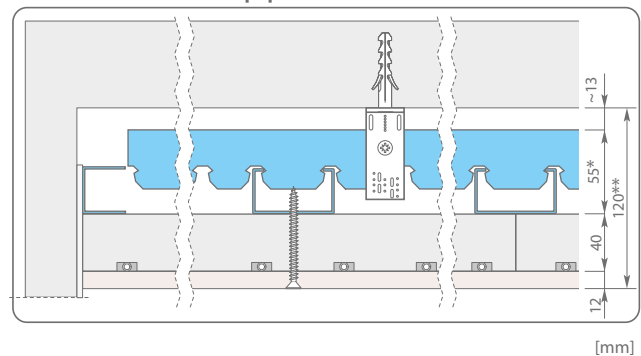

* Variable dimension depending on the profile used.

** If possible, to facilitate installation, we suggest a minimum height of 150 mm.

PRODUCTS THAT COMPOSE THE SYSTEM



Panel features
Dimensions: 1200x1200x50 mm

INSULATION	WEIGHT	CODE
Polystyrene	14.8 Kg	6143102



Panel features
Dimensions: 600x120x50 mm

INSULATION	WEIGHT	CODE
Polystyrene	7.5 Kg	6143162

b!klimax 8+ HP panel

Radiant panel b!klimax 8+ HP consisting of a plasterboard sheet (characterised by exceptionally high thermal conductivity due to the addition of expanded graphite granules to the plaster core) and polystyrene insulation layer. On the plasterboard, 2 hydraulic circuits are fixed by means of an aluminium metal diffuser made of PE-RT pipes \varnothing 8 mm (with quick coupling) equipped with an oxygen diffusion barrier according to DIN 4726. A layer of moulded polystyrene insulation with a thickness of 40 mm and a density of 30 kg/m³, equipped with a special housing for the pipes, ensures the thermal insulation of the whole.

Covered Plasterboard	600	1200	Unit	Standard
Panel Dimensions	600x1200	1200x1200	mm	EN 520
Nominal thickness	10		mm	EN 520
Weight	≈ 8.5		Kg/m ²	
Fire reaction class	A2-s1,d0			EN 13501-1
Thermal conductivity	0.52		W/(m·K)	DIN 12664
Resistance to vapour diffusion (dry)	$\mu = 10$ Equivalent air thickness $s_{d,e} = 0.1$ m			DIN 4108
Breaking load	≥ 430 longitudinal dir. ≥ 168 transversal dir.		N	EN 520
Resistance to bending	≥ 7.5 longitudinal dir. ≥ 2.9 transversal dir.		N/mm ²	EN 520
Surface hardness	10±18 (Brinell)		N/mm ²	-

Polystyrene Panel	600	1200	Unit	Standard
Size of the panel	600x1200	1200x1200	mm	UNI EN 822
Standard thickness	40		mm	UNI EN 823
Thickness of the insulating base	32		mm	UNI EN 1264-3
Bending strength	BS	170	kPa	UNI EN 12089
Compressive stress at 10% deformation	CS(10)	120	kPa	UNI EN 826
Thermal conductivity at 10 °C	λ_d	0.035	W/(m·K)	UNI EN 12667
Thermal resistance	Rd	1.10	(m ² ·K)/W	UNI EN 12667
Thermal transmittance	U	0.90	W/(m ² ·K)	
Water vapour diffusion resistance factor	μ	30 ÷ 70		UNI EN 12086
Water vapour permeability	δ	0.009 ÷ 0.020	mg/(Pa·h·m)	UNI EN 12086
Dimensional stability at 48h and 70 °C	DS(70,-)	1	%	UNI EN 1604
Long term water absorption by partial immersion	WIp	0.5	Kg/m ²	UNI EN 12087
Long term water absorption by total immersion	WI(T)	≤3	%	UNI EN 12087
Reaction to fire	Euroclass	E		EN ISO 11925-2
Limit of operating temperature		70	°C	
Dichiarazione secondo UNI EN 13163	T1-L3-W2-S2-P5-BS170-CS(10)120-DS(70,-)1-WL(T)3-MU(30-70)			

PE-RT pipe characteristics					
Application field		CLASS 4	For use with hot and cold water	T _{max} 70 °C	Pressure 8 bar
		CLASS 5	For use with hot and cold water	T _{max} 90 °C	Pressure 6 bar
Outside diam. (mm)	Thickness (mm)	Circuit Length (mm)		Weight (g/m)	Water content (l/m)
8	1	600	1200	22	0.028
		12	24		

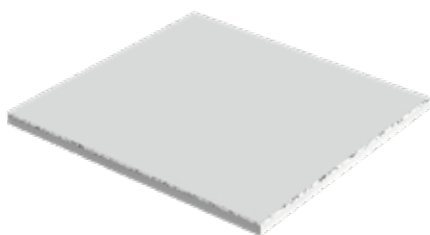

Blank panel

Passive panel consisting of standard plasterboard, without hydraulic circuits and available with polystyrene insulation. Necessary for filling areas not covered by radiant panels and areas where distributors are housed.

Panel features
1200x1200x50 mm

INSULATION	WEIGHT	CODE
Polystyrene	13.9 Kg	6143107



70-mm Fixing Screws

70-mm screws to fix b!klimax+ panels with plasterboard to the metal grid.

SIZE	CODE
70 mm	6510010

THERMAL OUTPUT OF THE SYSTEM

Thermal output in heating - ceiling

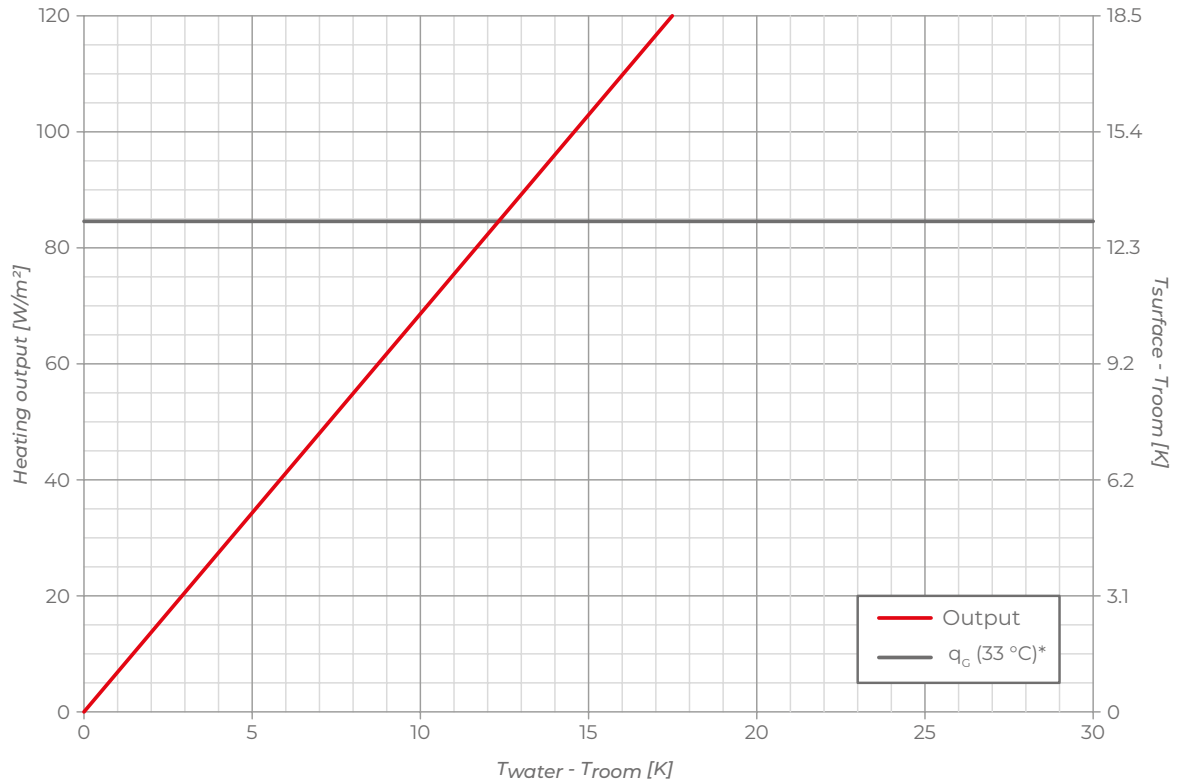

Thermal output in heating - wall

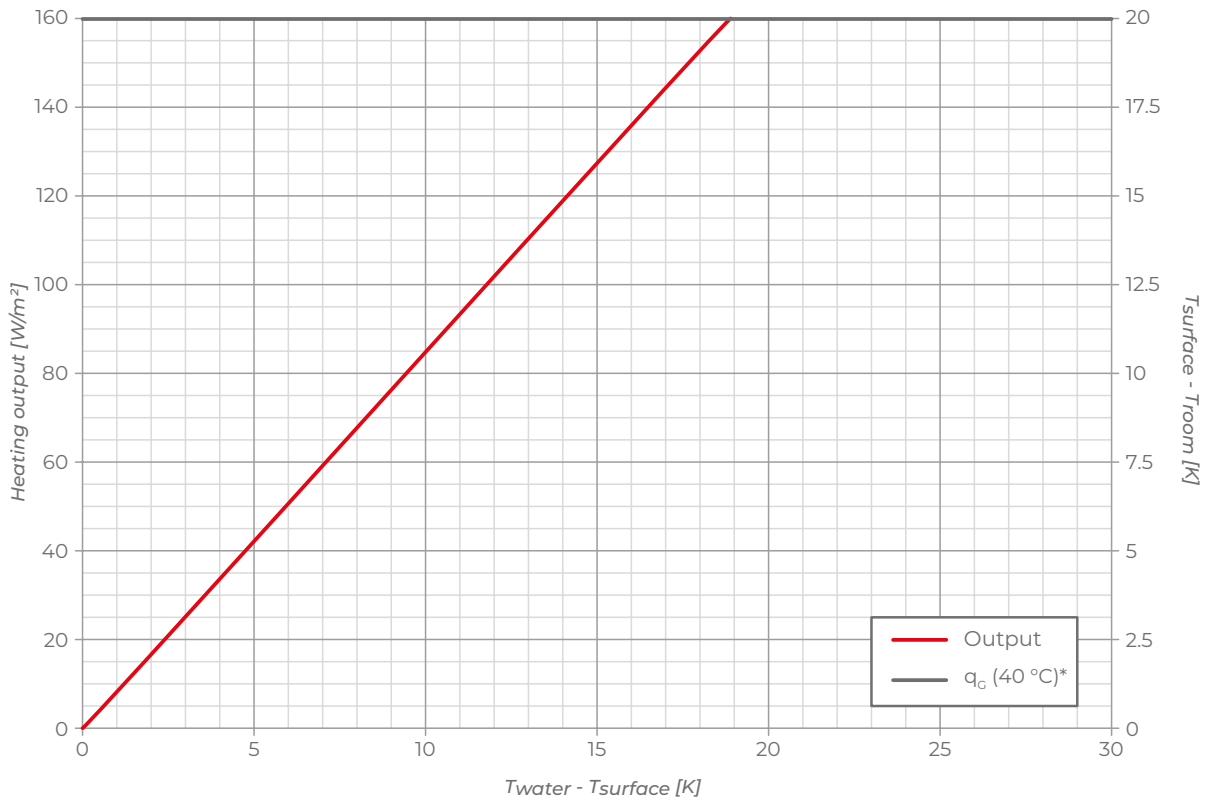

q_c : limit output
 *valid only for room temperature= 20 °C

Thermal output in cooling - ceiling

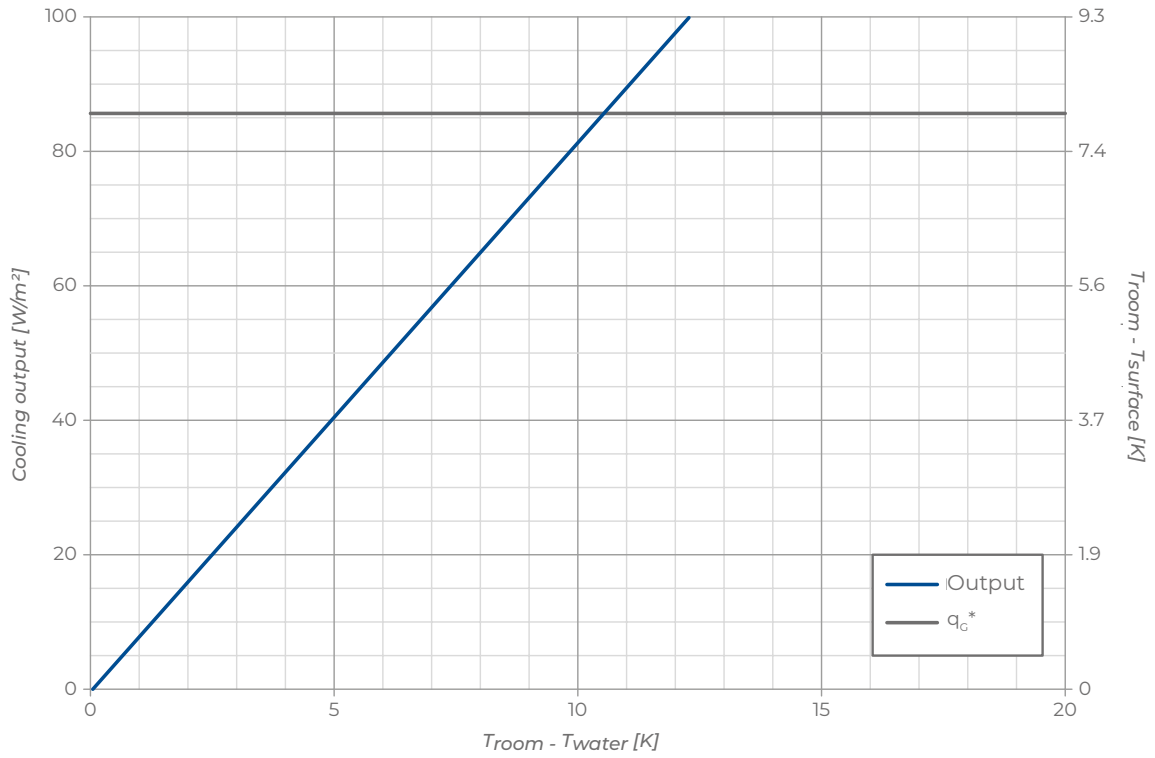

Thermal output in cooling - wall

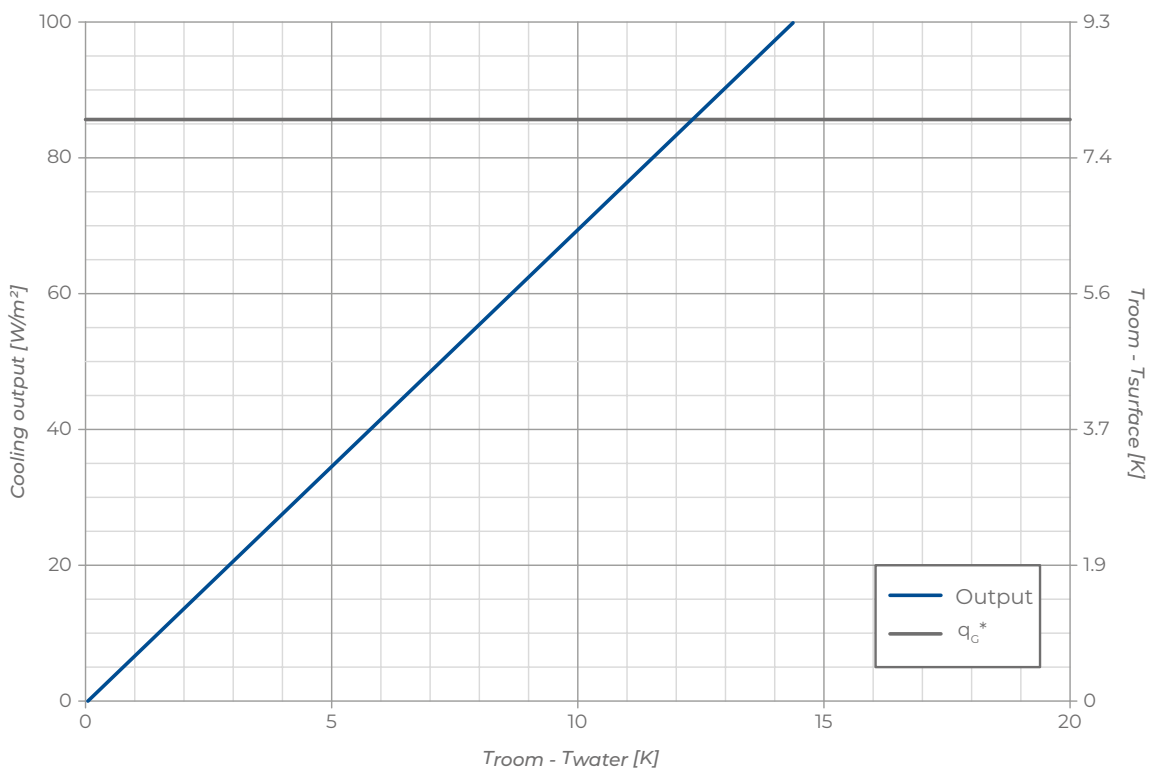

q_c^* : limit output
 *valid only for room temperature= 26 °C 55% R.H.

COMPLEMENTS FOR SYSTEMS WITH Ø 8 PIPE



Pre-insulated pipe Ø 20 mm

PB pipe with oxygen barrier according to DIN 4726 EN 12319-2, Ø 20 mm, pipe insulation made of expanded polyethylene, thickness 6 mm. Reaction to fire class: BL-s2, d0. It is used to connect distributors with b!klimax manifolds.

TYPE	SIZE	CODE
red roll 50 m	Ø 20 mm	6200020
blu roll 50 m	Ø 20 mm	6201020

Note:
for further technical data see page 50



2-way Distributors Ø 8 mm

Pair of distributors made of plastic, specially shaped to guarantee easy connection with the pipes coming from Copper 8 and Quadrotto HP tiles. These distributors are provided with anti-condensation shells made of polystyrene or expanded polyethylene BL-s1, d0, push-fit pipe fittings for pipes Ø 8 mm and Ø 20 mm, and closing plastic bands.

MODEL	INSULATION	CODE
2-way open	polystyrene	6210080
2-way open	polyethylene	6210082



4-way Distributors Ø 8 mm

Pair of distributors made of plastic, specially shaped to guarantee easy connection with the pipes coming from Copper 8 and Quadrotto HP tiles. These distributors are provided with anti-condensation shells made of polystyrene or expanded polyethylene BL-s1, d0, push-fit pipe fittings for pipes Ø 8 mm and Ø 20 mm, and closing plastic bands.

MODEL	INSULATION	CODE
4-way open	polystyrene	6210081
4-way open	polyethylene	6210083



Straight Push-fit Fitting

Straight push-fit fitting used as connection for polybutylene pipes Ø 8 mm. Transparent versione. Condensation shells made of polyethylene BL-s1, d0.

SIZE	INSULATION	CODE
Ø 8 mm	polyethylene	6510018
Ø 20 mm	polyethylene	6510026



TEE Push-fit Fitting 20-20-20 mm

TEE push-fit fitting used as connection for PB pipes Ø 20 mm. It's provided with anticondensation insulation shells available in polystyrene or polyethylene BL-s1, d0.

SIZE	INSULATION	CODE
Ø 20 mm	polystyrene	6510055
Ø 20 mm	polyethylene	6510056



Cross Push-fit Fitting 20-20-20-20 mm

This cross push-fit fitting is used as connection for polybutylene pipes Ø 20 mm. It's provided with anticondensation insulation shells available in polystyrene or polyethylene BL-s1, d0.

SIZE	INSULATION	CODE
Ø 20 mm	polystyrene	6510065
Ø 20 mm	polyethylene	6510066



Elbow Push-fit Fitting 20-20 mm

This ELBOW push-fit fitting is used as 90° shifting for polybutylene pipes Ø 20 mm. It's provided with polyethylene BL-sl, d0 insulation or without it.

SIZE	INSULATION	CODE
Ø 20 mm	- -	6510075
Ø 20 mm	polyethylene	6510076



PE-RT pipe Ø 8 mm

PE-RT pipe Ø 8 mm with oxygen barrier according to DIN 4726 DIN EN ISO 21003-2, thickness 1 mm. It is used to connect b!klimax+ Copper 8 and Quadrotto HP tiles with the distributors.

SIZE	CODE
Ø 8 mm	6210018

Note:
for further technical data see page 52



Insulation for PE-RT pipe Ø 8 mm

Insulation for PE-RT pipe Ø 8 mm made of expanded polyethylene, thickness 6 mm. Reaction to fire class: BL -sl, d0.

SIZE	CODE
Ø 8 mm	6320008



Lubricant for Push-fit Pipe Fittings

This lubricant is used to guarantee better insertion of the pipes into the fittings and better preservation of O-rings. (1 package every 75 circuits).

SIZE	CODE
20 ml	6603000



Closing Plugs for Outlets Ø 8 mm and Ø 20 mm

Plastic plugs are used to close the unused outlets in a distributor.

SIZE	CODE
Ø 8 mm	6510041
Ø 20 mm	6510050



Industry System elbow

Elbow for 90° shifting with pipes Ø 20 mm.

SIZE	CODE
Ø 20 mm	1140025



b!klimax Perimeter belt

Edge insulation for b!klimax and b!klimax+ ceiling systems, made of closed-cell expanded polyethylene. It acts as thermo-acoustic insulation and it absorbs plasterboard ceiling expansions.

SIZE	CODE
h 150 mm	6603010



Spare parts kit

Replacement kit for b!klimax fittings and distributors including all the components needed to restore a pipe connection.

SIZE	CODE
for Ø 8 mm pipe	6510071
for Ø 20 mm pipe	6510080



b!klimax+ Quadrotti is a ceiling heating and cooling system specifically designed for the commercial applications, consisting of metal ceilings or plasterboard panels onto which, by an aluminium diffuser, the \varnothing 6 mm pipe is fixed. Thermal insulation is provided by a layer of polystyrene or rockwool.

The metal version, available in 600x600 mm or 1200x600 mm, consists of post-painted steel radiant ceilings with rounded corners and microperforated surface with 20 mm smooth edge; the plasterboard version consists of a RAL 9003 white plasterboard sheet with high performance in terms of light reflection and soundproof performances.

The installation on a metal structure for false ceilings with inverted T profiles allows the cavity to be inspected and can be used to hide other systems.

The system is completed with the manifold, the distributors, the fittings, the pre-insulated polybutylene pipe \varnothing 20 mm for connecting the distributors to the manifold and the pre-insulated PB pipe \varnothing 6 mm for connecting the squares to the distributors.

FEATURES

- Ceiling installation
- Installation on metal structure for false ceiling with inverted T-profiles
- Polystyrene or rockwool insulation
- Specific for commercial applications
- Inspectionable false ceiling



SECTION OF THE SYSTEM

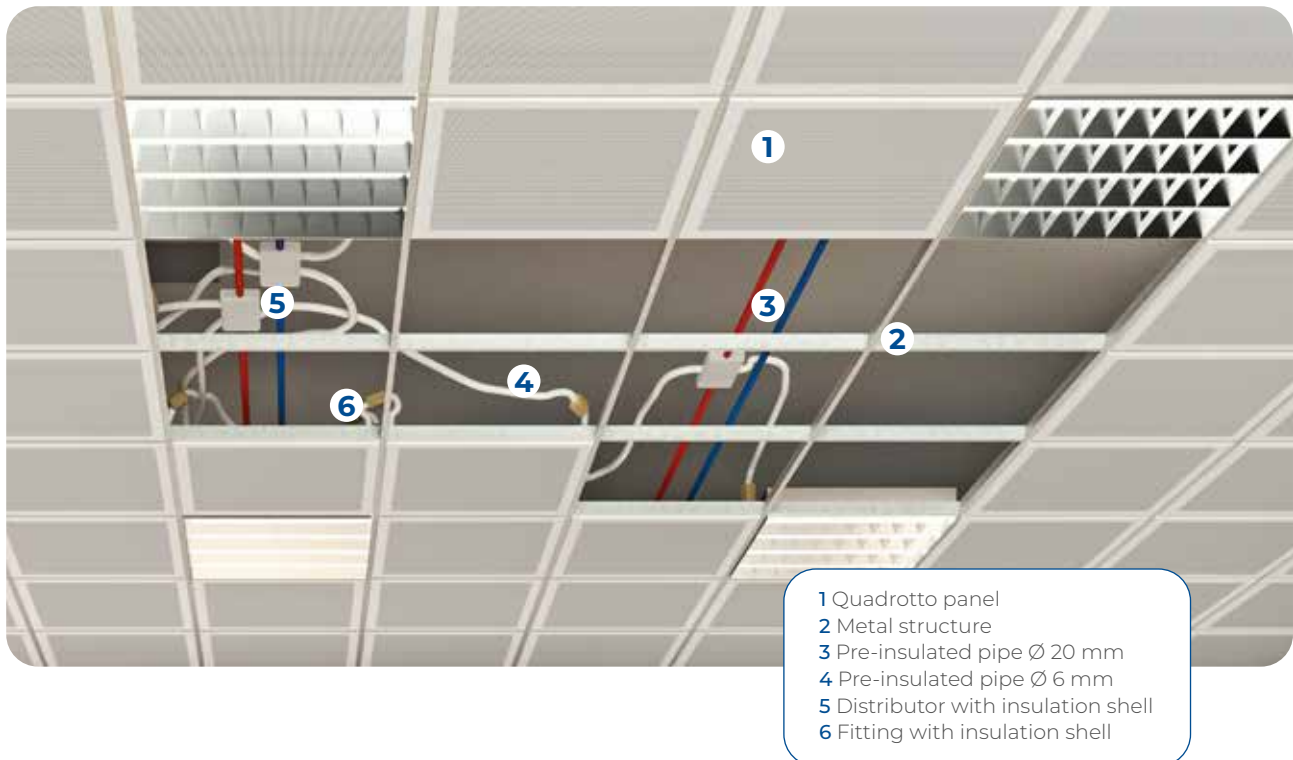

SUPPORT STRUCTURE

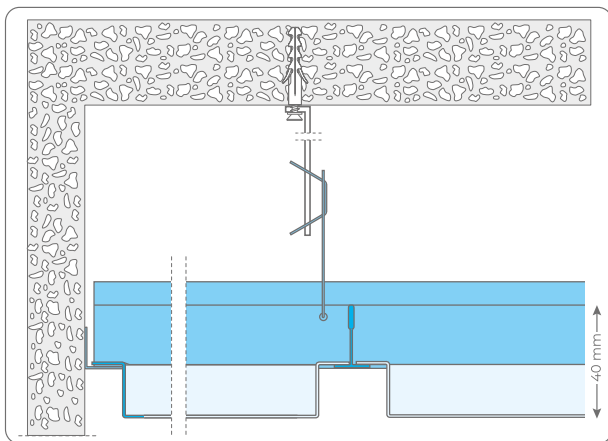

The **b!klimax+ Quadrotti** metal radiant panels are designed to be installed on the ceiling on a T-shaped metal support frame with a 15 mm base that emphasises its three-dimensionality, guaranteeing excellent aesthetic performance of the system. The structure can be equipped with a special “anti-seismic kit” to respond to the safety and stability requirements of the ceiling in all areas with high seismic risk.



CUSTOMIZED ACTIVATION

The radiant technology used in the Metal **b!klimax+ Quadrotti** systems can be adapted to a wide range of commercially available ceilings with a unique and personalized result.

For this reason, **after a feasibility analysis**, we offer a service of just creating the radiant activation of metal ceiling mounts other than the versions available in the catalogue that can be procured directly from our company or supplied by the customer on a subcontract basis.

For further information, please contact your local agent or contact us by writing to info@rdz.it

PRODUCTS THAT COMPOSE THE SYSTEM

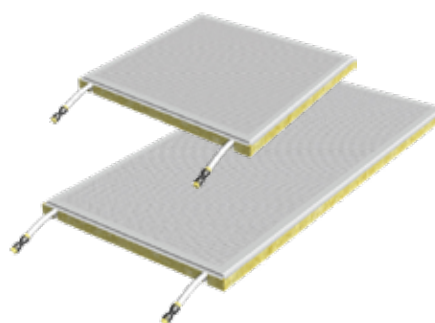
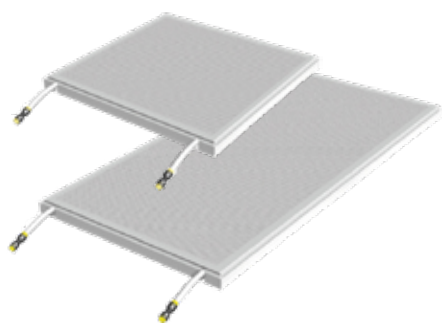

Polystyrene Quadrotto features

SIZE	WEIGHT	CODE
600x600x40	1.9 Kg	6140600
1200x600x40	3.7 Kg	6141200

Rockwool Quadrotto features

SIZE	WEIGHT	CODE
600x600x40	4.1 Kg	6140610
1200x600x40	7.2 Kg	6141210

Radiant metal Quadrotto

The metal radiant panel consists of a 5/10 post painted RAL 9016 steel ceiling with 15 mm base and 8 mm lowered right angle, microperforated surface and 20 mm smooth edge. The hydraulic circuit consisting of Ø 6 mm pipework is fixed to the ceiling via an aluminium diffuser. The panel is available with polystyrene or rockwool (fire reaction class: A1) insulation.

Sheet metal ceiling characteristics	600	1200	Unit
Material	Steel 5/10		
Smooth perimeter	20		mm
Base	15	24	mm
Rebate	8		mm

Polystyrene insulation characteristics		600	1200	Unit	Standard
Size of insulating panel		593x593	1190x593	mm	UNI EN 822
Standard thickness		40		mm	UNI EN 823
Insulation base thickness		34		mm	UNI EN 1264-3
Bending strength	BS	170		kPa	UNI EN 12089
Compressive stress at 10% deformation	CS(10)	120		kPa	UNI EN 826
Thermal conductivity 10 °C	λd	0.035		W/(m·K)	UNI EN 12667
Thermal resistance	Rd	1.05		(m ² ·K)/W	UNI EN 12667
Thermal transmittance	U	0.95		W/(m ² ·K)	
Water vapour diffusion resistance factor	μ	30 ÷ 70			UNI EN 12086
Water vapour permeability	δ	0.009 ÷ 0.020		mg/(Pa·h·m)	UNI EN 12086
Dimensional stability at 48h and 70 °C	DS(70,-)	1		%	UNI EN 1604
Long term water absorption by partial immersion	Wlp	0.5		Kg/m ²	UNI EN 12087
Long term water absorption by total immersion	WI(T)	≤3		%	UNI EN 12087
Fire reaction	Euroclass	E			EN ISO 11925-2
Limit of operating temperature		70		°C	
Declaration according to UNI EN 13163		T1-L3-W2-S2-P5-BS170-CS(10)120-DS(70,-)1-WL(T)3-MU(30-70)			

Rock wool insulation characteristics		600	1200	Unit	Standard
Size of insulating panel		600x600	1200x600	mm	UNI 822
Standard thickness		40		mm	UNI 823
Declared thermal conductivity	λ_d	0.040		W/(m·K)	UNI EN 12667, 12939
Thermal resistance	R_d	1		(m ² ·K)/W	
Resistance to compression 10%	σ_{10}	70		kPa	UNI EN 826
Resistance to point load	F_p	600		N	UNI EN 12430
Tensile bond strength	σ_{mt}	15		kPa	UNI EN 1607
Water vapour diffusion resistance factor	μ	1			UNI EN 12086
Short term water absorption by partial immersion	W_s	< 1		kg/m ²	EN 1609
Long term water absorption by partial immersion	$W_l(p)$	< 3		kg/m ²	EN 12087
Specific heat	C_p	1030		J/(KgK)	UNI EN 12524
Density	ρ	165		Kg/m ³	UNI EN 1602
Fire reaction	Euroclass	A1			UNI EN 13501-1
Declaration according to UNI EN 13162		MW-EN 13162 T5-CS(10/Y)70-PL(5)600-TR15-DS(TH)-DS(T+)-MUI-WS-WL(p)			

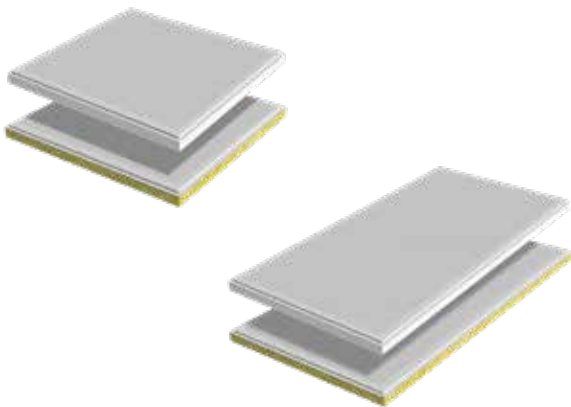

Blank metal panel

Passive panel without hydraulic circuit, consisting of a 5/10 post painted RAL 9016 steel metal ceiling with 15 mm base, microperforated surface and 20 mm smooth edge.

Available with polystyrene or rockwool (fire reaction class: A1) insulation.

Panel features

INSULATION	SIZE	WEIGHT	CODE
Polystyrene	600x600x40	1.7 Kg	6140605
Rockwool	600x600x40	4.0 Kg	6140615
Polystyrene	1200x600x40	3.6 Kg	6141205
Rockwool	1200x600x40	7.3 Kg	6141215

PRODUCTS THAT COMPOSE THE SYSTEM

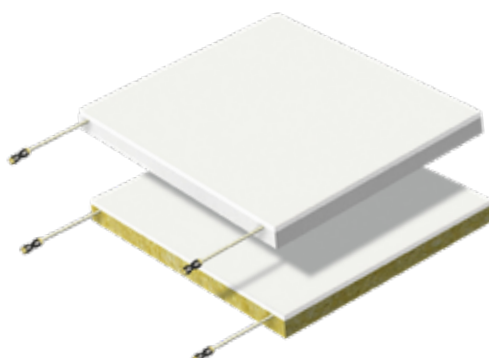

Panel features

Dimensions: 600x600x50 mm

INSULATING	WEIGHT	CODE
Polystyrene	3.7 Kg	6140500
Rockwool	5.2 Kg	6140550

Radiant plasterboard Quadrotto

The radiant plasterboard Quadrotto is composed of a smooth plasterboard sheet 9 mm thick, white RAL 9003, with high performance in terms of light reflection and absorption of acoustic reverberation. The hydraulic circuit consisting of a \varnothing 6 mm pipe is fixed to the panel by an aluminium diffuser. Quadrotto is available with polystyrene or rockwool (fire reaction class rock wool: A1) insulation.

Plasterboard sheet characteristics	Value	Unit
Size	600x600	mm
Standard thickness	9.5	mm
Fire reaction	A2-s1,d0	
Thermal conductivity λ	0.2108	W/(m·K)

Polystyrene insulation characteristics		Value	Unit	Standard
Size of insulating panel		593x593	mm	UNI EN 822
Standard thickness		40	mm	UNI EN 823
Insulation base thickness		34	mm	UNI EN 1264-3
Bending strength	BS	170	kPa	UNI EN 12089
Compressive stress at 10% deformation	CS(10)	120	kPa	UNI EN 826
Thermal conductivity 10 °C	λ_d	0.035	W/(m·K)	UNI EN 12667
Thermal resistance	Rd	1.05	(m ² ·K)/W	UNI EN 12667
Thermal transmittance	U	0.95	W/(m ² ·K)	
Water vapour diffusion resistance factor	μ	30 ÷ 70		UNI EN 12086
Water vapour permeability	δ	0.009 ÷ 0.020	mg/(Pa·h·m)	UNI EN 12086
Dimensional stability at 48h and 70 °C	DS(70,-)	1	%	UNI EN 1604
Long term water absorption by partial immersion	WIp	0.5	Kg/m ²	UNI EN 12087
Long term water absorption by total immersion	WI(T)	≤3	%	UNI EN 12087
Fire reaction	Euroclass	E		EN ISO 11925-2
Limit of operating temperature		70	°C	
Declaration according to UNI EN 13163		T1-L3-W2-S2-P5-BS170-CS(10)120-DS(70,-)1-WL(T)3-MU(30-70)		

Rockwool insulation characteristics		Value	Unit	Standard
Size of insulating panel		600x600	mm	UNI 822
Standard thickness		40	mm	UNI 823
Declared thermal conductivity	λ_d	0.040	W/(m·K)	UNI EN 12667, 12939
Thermal resistance	Rd	1	(m ² ·K)/W	
Resistance to compression 10%	σ_{10}	70	kPa	UNI EN 826
Resistance to point load	F _p	600	N	UNI EN 12430
Tensile bond strength	σ_{mt}	15	kPa	UNI EN 1607
Water vapour diffusion resistance factor	μ	1		UNI EN 12086
Short term water absorption by partial immersion	Ws	< 1	kg/m ²	EN 1609
Long term water absorption by partial immersion	WI(p)	< 3	kg/m ²	EN 12087
Specific heat	C _p	1030	J/(KgK)	UNI EN 12524
Density	ρ	165	Kg/m ³	UNI EN 1602
Fire reaction	Euroclass	A1		UNI EN 13501-1
Declaration according to UNI EN 13162		MW-EN 13162 T5-CS(10/Y)70-PL(5)600-TR15-DS(TH)-DS(T+)-MU1-WS-WL(p)		

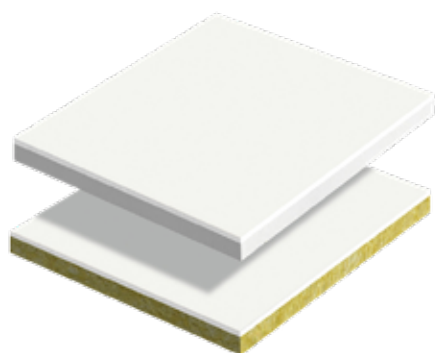

Blank plasterboard panel

Passive panel without hydraulic circuit, with smooth plasterboard sheet, 9 mm thick, white RAL 9003, with high performance in terms of light reflection and absorption of acoustic reverberation. Available with polystyrene or rockwool (fire reaction class rock wool: A1) insulation.

Panel features

Dimensions: 600x600x40 mm

INSULATION	WEIGHT	CODE
Polystyrene	3.4 Kg	6140510
Rockwool	5.0 Kg	6140560

PRODUCTS THAT COMPOSE THE SYSTEM

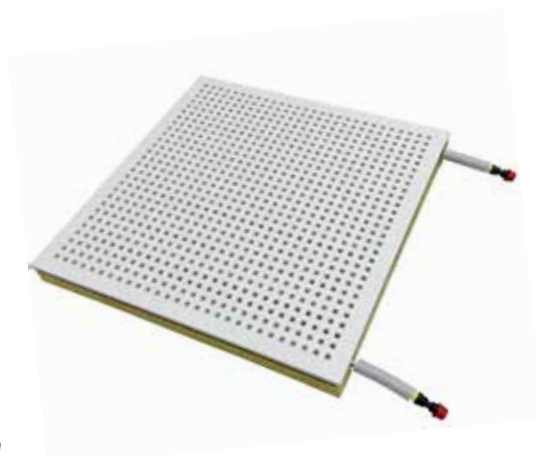

Quadrotto features

Dimensions: 600x600x50 mm

INSULATION	WEIGHT	CODE
Rockwool	4.9 Kg	6140552

Acoustic radiant plasterboard Quadrotto

Radiant panel consisting of a slab with regular square holes, thickness 10 mm, satin finish colour RAL 9010 with high performance: sound absorption ($\alpha_w=0,4$) of the reverberation generated inside the room, light reflection (approx. 70%) and absorption of up to 70% of the formaldehyde in the room. Complete with hydraulic circuit consisting of \varnothing 6 mm pipe and rockwool insulation (fire reaction class: A1).

Acoustic plasterboard panel					
Characteristic	Value	Unit	Characteristic	Value	Unit
Size of insulating panel	600x600	mm	Structure	24/15	
Nominal Thickness	10	mm	Holes section	9x9	mm
Holes pitch	19,5	mm	Humidity resistance	RH 70	
Fire reaction: Euroclass A2-s1,d0 standard EN 13501-1					
Brightness (light reflection coefficient)	~70	%			

Rockwool insulation		Value	Unit	Standard
Size of insulating panel		600x600	mm	UNI 822
Standard thickness		40	mm	UNI 823
Declared thermal conductivity	λ_d	0,040	W/(m·K)	UNI EN 12667, 12939
Thermal resistance	Rd	1	(m ² ·K)/W	
Compressive stress at 10% deformation	σ_{10}	70	kPa	UNI EN 826
Resistance to point load	Φ_p	600	N	UNI EN 12430
Tensile bond strength	σ_{mt}	15	kPa	UNI EN 1607
Water vapour diffusion resistance factor	μ	1		UNI EN 12086
Short term water absorption by partial immersion	Ws	<1	kg/m ²	EN 1609
Long term water absorption by partial immersion	WI(p)	<3	kg/m ²	EN 12087
Specific heat	CP	1030	J/(KgK)	UNI EN 10456
Density	ρ	165	Kg/m ³	UNI EN 1602
Fire reaction	Euroclass	A1		UNI EN 13501-1
Declaration according to UNI EN 13162	MW-EN 13162 T5-CS(10/Y)70-PL(5)600-TR15-DS(TH)-DS(T+)-MUI-WS-WL(p)			

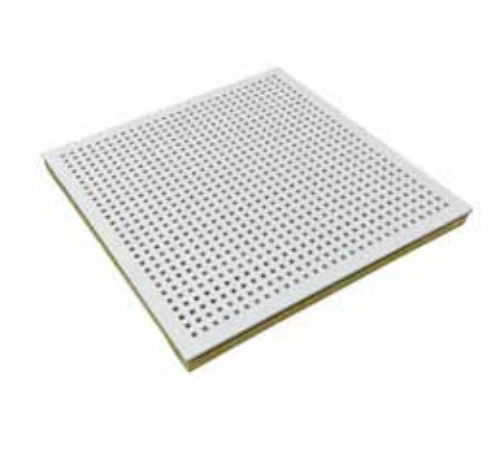

Acoustic blank plasterboard panel

Passive panel without hydraulic circuit, with regular square perforated plasterboard sheet, 10 mm thick, white RAL 9010, with high performance in terms of acoustic reverberation absorption ($\alpha_w=0,8$), light reflection and absorption of up to 70% of formaldehyde in the room.

Rockwool insulation (fire reaction class rock wool: A1).

Quadrotto features

Dimensions: 600x600x50 mm

INSULATION	WEIGHT	CODE
Rockwool	4.7 Kg	6140562

THERMAL OUTPUT OF THE SYSTEM WITH METAL QUADROTTI

Thermal output in heating - ceiling

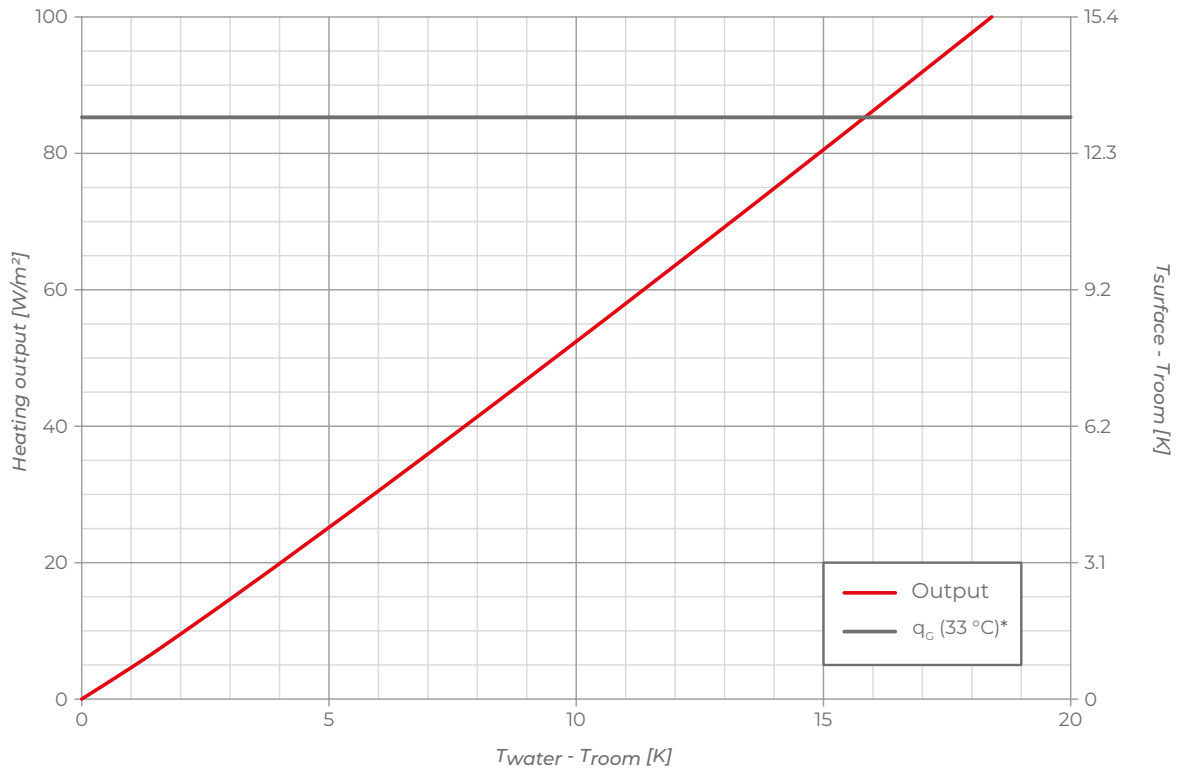

Thermal output in cooling - ceiling

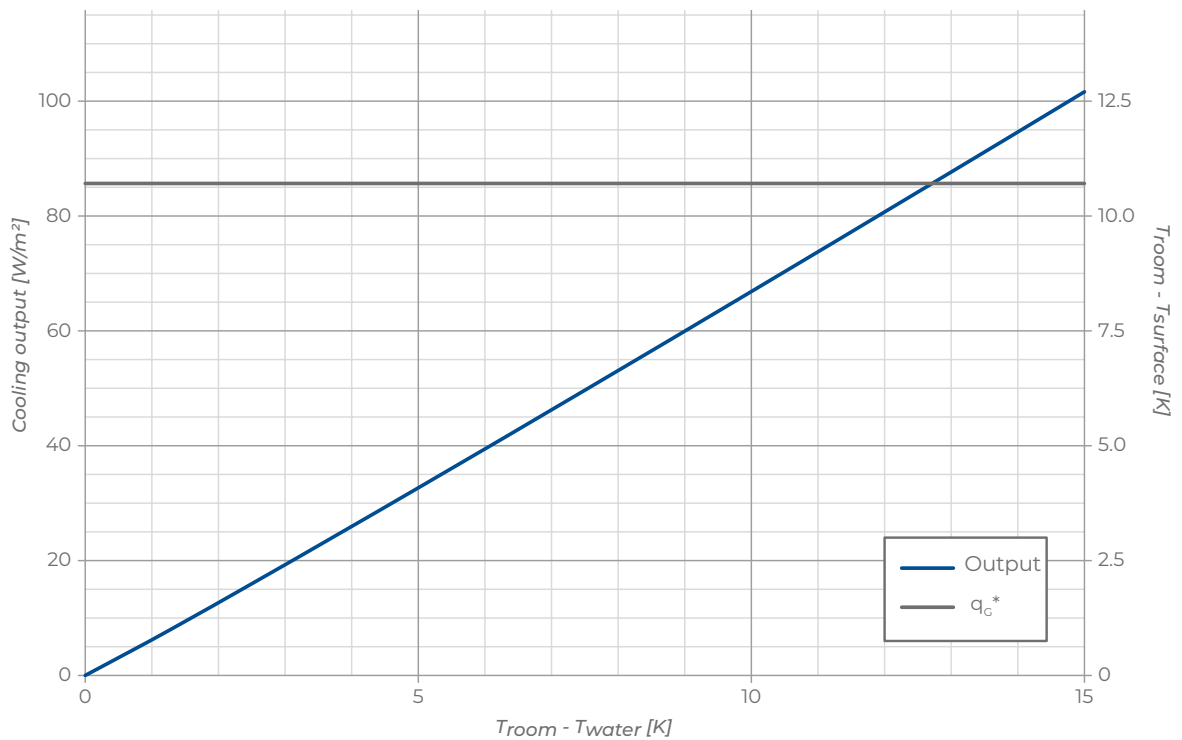

q_c : limit output
 *valid only for room temperature= 26 °C 55% R.H.

■ THERMAL OUTPUT OF THE SYSTEM WITH STANDARD PLASTERBOARD QUADROTTI AND ACOUSTIC PLASTERBOARD QUADROTTI

Thermal output in heating - ceiling

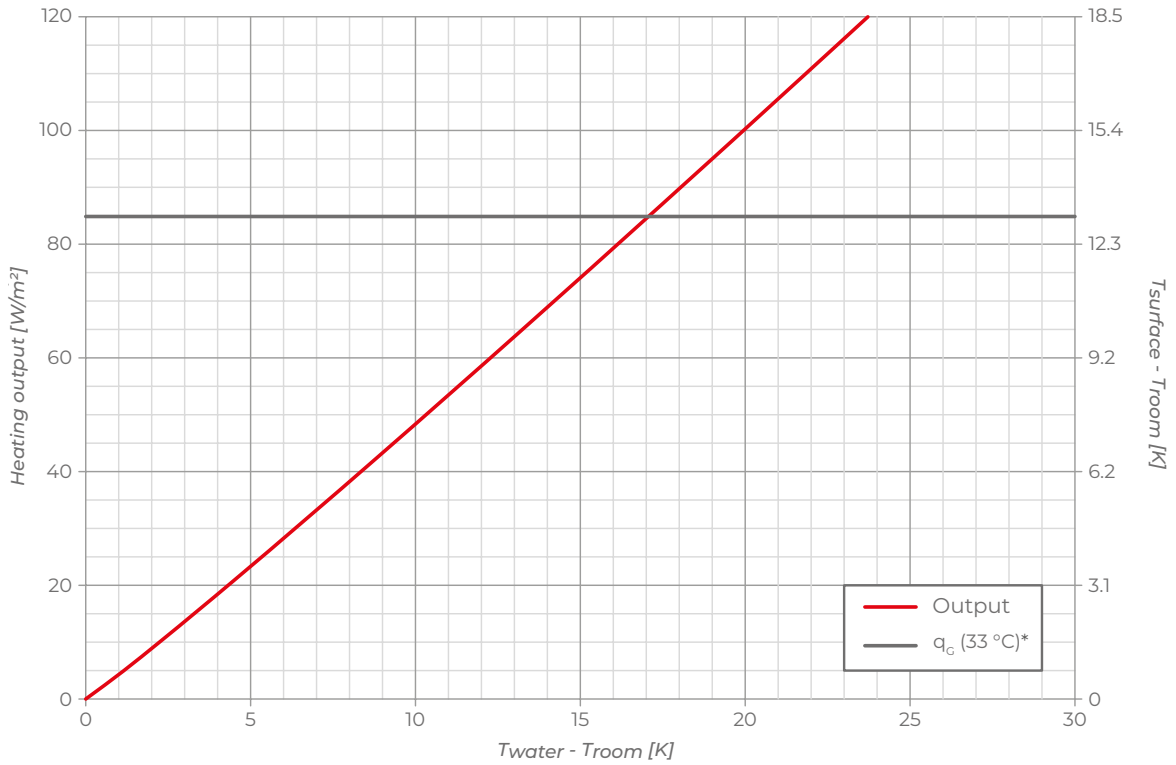

Thermal output in cooling - ceiling

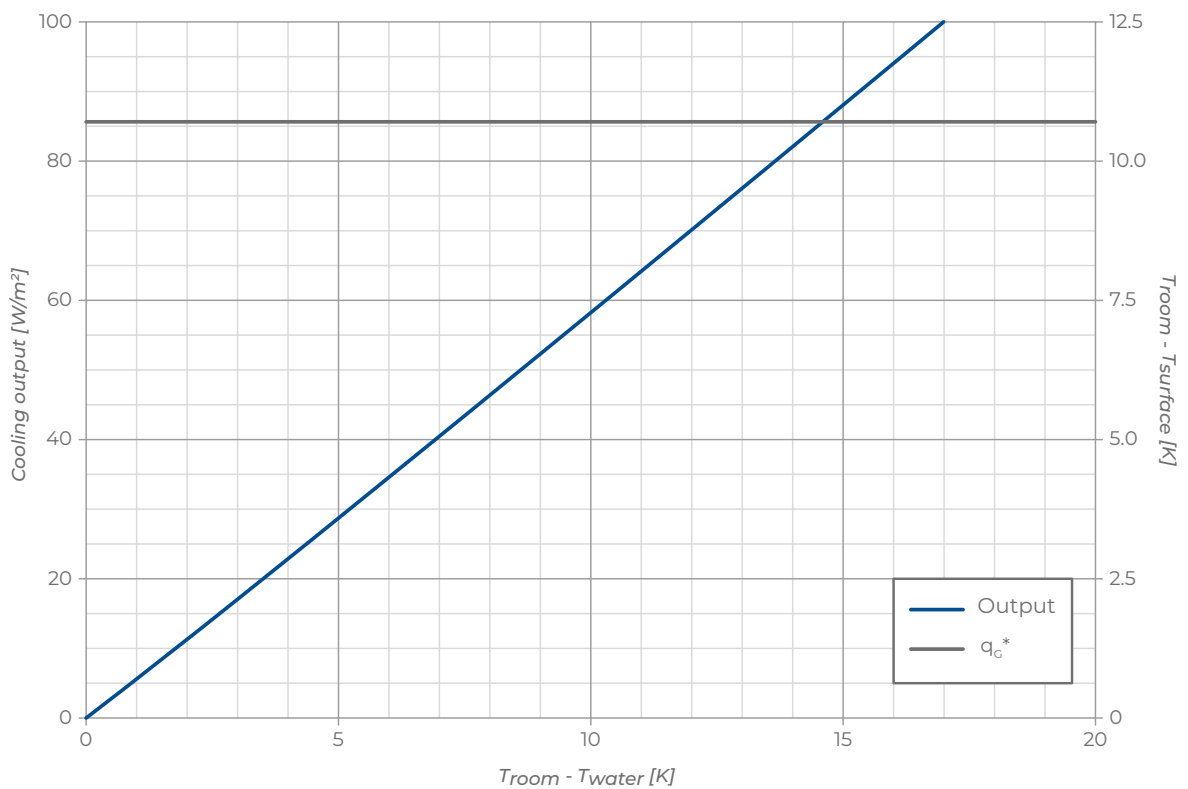

q_c : limit output
 *valid only for room temperature= 26 °C 55% R.H.

COMPLEMENTS FOR SYSTEMS WITH Ø 6 PIPE



Pre-insulated pipe Ø 20 mm

PB pipe with oxygen barrier according to DIN 4726 EN 12319-2, Ø 20 mm, pipe insulation made of expanded polyethylene, thickness 6 mm. Reaction to fire class: BL-s2, d0. It is used to connect distributors with b!klimax manifolds.

TYPE	SIZE	CODE
red roll 50 m	Ø 20 mm	6200020
blu roll 50 m	Ø 20 mm	6201020

Note:
for further technical data see page 50



8-way Distributors

Pair of distributors made of plastic, specially shaped to guarantee easy connection with the pipes coming from b!klimax panels. These distributors are provided with anticondensation shells made of polystyrene or expanded polyethylene BL-s1, d0, push-fit pipe fittings for pipes Ø 6 mm and Ø 20 mm, and closing plastic bands.

MODEL	INSULATION	CODE
8-way open	polystyrene	6210040
8-way open	polyethylene	6210041
8-way terminal	polystyrene	6210050
8-way terminal	polyethylene	6210051



4-way Distributors

Pair of distributors made of plastic, specially shaped to guarantee easy connection with the pipes coming from b!klimax panels. These distributors are provided with anticondensation shells made of polystyrene or expanded polyethylene BL-s1, d0, push-fit pipe fittings for pipes Ø 6 mm and Ø 20 mm, and closing plastic bands.

MODEL	INSULATION	CODE
4-way open	polystyrene	6210060
4-way open	polyethylene	6210061
4-way terminal	polystyrene	6210070
4-way terminal	polyethylene	6210071



Straight Push-fit Fitting Ø 6 mm

Straight push-fit fitting used as connection for polybutylene pipes Ø 6 mm. It's provided with anticondensation insulation shells available in polystyrene or polyethylene BL-s1, d0.

SIZE	INSULATION	CODE
Ø 6 mm	polystyrene	6510006
Ø 6 mm	polyethylene	6510016
Ø 20 mm	polyethylene	6510026



TEE Push-fit Fitting 20-20-20 mm

TEE push-fit fitting used as connection for PB pipes Ø 20 mm. It's provided with anticondensation insulation shells available in polystyrene or polyethylene BL-s1, d0.

SIZE	INSULATION	CODE
Ø 20 mm	polystyrene	6510055
Ø 20 mm	polyethylene	6510056



Cross Push-fit Fitting 20-20-20-20 mm

This cross push-fit fitting is used as connection for polybutylene pipes Ø 20 mm. It's provided with anticondensation insulation shells available in polystyrene or polyethylene BL-s1, d0.

SIZE	INSULATION	CODE
Ø 20 mm	polystyrene	6510065
Ø 20 mm	polyethylene	6510066



Elbow Push-fit Fitting 20-20 mm

This ELBOW push-fit fitting is used as 90° shifting for polybutylene pipes Ø 20 mm. It's provided with polyethylene BL-sl, d0 insulation or without it.

SIZE	INSULATION	CODE
Ø 20 mm	- -	6510075
Ø 20 mm	polyethylene	6510076



Pre-insulated PB Pipe Ø 6 mm

PB pipe Ø 6 mm with oxygen barrier according to DIN 4726 EN 12319-2, pipe insulation made of expanded polyethylene, reaction to fire class BL-sl,d0, thickness 6 mm. It is used to connect b!klimax+ and Quadrotto panels to the distributors.

SIZE	CODE
Ø 6 mm	6210006

Note:
for further technical data see page 51



Lubricant for Push-fit Pipe Fittings

This lubricant is used to guarantee better insertion of the pipes into the fittings and better preservation of O-rings. (1 package every 75 circuits).

SIZE	CODE
20 ml	6603000



Closing Plugs for Outlets Ø 6 and 20 mm

Plastic plugs are used to close the unused outlets in a distributor.

SIZE	CODE
Ø 6 mm	6510040
Ø 20 mm	6510050



Industry System Elbow

Elbow for 90° shifting with pipes Ø 20 mm.

SIZE	CODE
Ø 20 mm	1140025



Spare parts kit

Replacement kit for b!klimax fittings and distributors including all the components needed to restore a pipe connection.

SIZE	CODE
for Ø 6 mm pipe	6510070
for Ø 20 mm pipe	6510080

**Ceiling and wall
radiant systems**

Complements



COMPLEMENTS FOR B!KLIMAX SYSTEMS



b!klimax Cabinet

This cabinet made of zinc-plated sheet iron is used to contain b!klimax manifolds. There are suitable outlets for pipes both upwards and downwards. The cabinet is equipped with a protective cover for plaster, a white metal door painted with epoxy powders, and lockset.

Model	A [cm]	B [cm]	C [cm]	Code
60	76	60	14	6431060
80	76	80	14	6431080
100	76	100	14	6431100

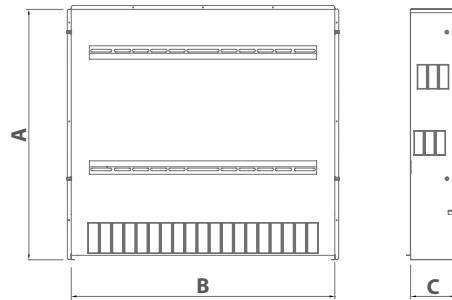

b!klimax Manifolds

The b!klimax manifold with female connection $\varnothing 1 \frac{1}{4}$ " is made of plastic material and has been designed for high flow-rate. It is equipped with shut-off valves suitable for electro-thermal heads, air vent and discharge valves, thermometers on supply and return flow, fixing brackets, Y filter and push-fit fittings with key for pipes $\varnothing 20$ mm. The b!klimax manifold can be installed horizontally or vertically with the pipes upwards or downwards. Anti-condensation shells are supplied as standard.

Performance and dimensions	Value
Liquid	water / glycolic water 50% at most
Normal operation pressure	0÷6 bar
Max. testing pressure	10 bar
Burst pressure	> 22 bar with room temperature / > 15 bar with 50 °C
Normal operation temperature	5÷55 °C
Max. temperature	90 °C a 3 bar
Main outlet of the manifold	1" 1/4 F Turning brass thread for the connection with circulation pump
Derivations	Pipe connection $\varnothing 20$ mm through push fit fitting with key sliding Distance between axis: 46.5 mm

Dimensions of the manifold												
Code		6302102	6302103	6302104	6302105	6302106	6302107	6302108	6302109	6302110	6302111	6302112
No. outlets		2+2	3+3	4+4	5+5	6+6	7+7	8+8	9+9	10+10	11+11	12+12
Manifold width	cm.	32	36	41	46	50	55	60	64	69	73	78

Eurocone adapter $\varnothing \frac{3}{4}$ " for b!klimax manifolds



Clutch Eurocone adapter $\varnothing \frac{3}{4}$ " to connect the pipes with b!klimax manifold.

CODE

6302140



Closing Plug for b!klimax Manifolds

Push button joint to close unused circuits on b!klimax manifolds.

CODE

6302135

RDZ Electrothermic Head



The thermo-electric actuator performs the shut-off function on each circuit with control by the room thermostat. It can be installed in any position, even upside-down. The function display of the actuator allows identifying the operating condition (open/closed). Easy slot assembly thanks to the adapter (supplied as standard). Voltage: 230V with or without micro-switch or 24V with micro-switch. Protection class: IP54 (all assembly positions). It can be used with b!klimax, TOP COMPOSIT, CONTROL and High-Temperature outlets for KITS.

VOLTAGE	CODE
230 V	1057230
230 V w/micro	1057240
24 V w/micro	1057250

Head characteristics	230 V	24 V
Operating voltage	230 V AC, +10%...-10%, 50/60 Hz	24 V AC/DC, +20%...-10%
Max. inrush current	< 550 mA during max. 100 ms	< 300 mA during max. 2 ms
Operating power	1 W *	1 W *
Stroke (actuator travel)	4.0 mm	4.0 mm
Actuating force	100 N ±5%	100 N ±5%
Fluid temperature	0 to +100°C **	0 to +100°C **
Storage temperature	-25°C to +60°C	-25°C to +60°C
Ambient temperature	0 to +60°C	0 °C to +60 °C
Type of protection / Class of protection	IP 54 *** / II	IP 54 (EN 60529) / II
CE conformity according to	EN 60730	EN 60730
Casing	Polyamide, colour: light grey (RAL 7035)	Polyamide, colour: light grey (RAL 7035)
Connection line	type: 2 x 0.75 mm ² PVC, colour: light gray (RAL 7035), length: 1 m	type: 4 x 0.75 mm ² PVC, colour: light gray (RAL 7035), length: 1 m
Weight with connecting cable (1 m)	100 g	(1 m): approx. 150 g
Surge protection according to EN 60730-1	min. 2.5 kV	

* measured with precision reference instrument LMG95 ** or higher, depending on the adapter length *** in all installation positions

Electrical connection

Electrothermic head 24 V with micro

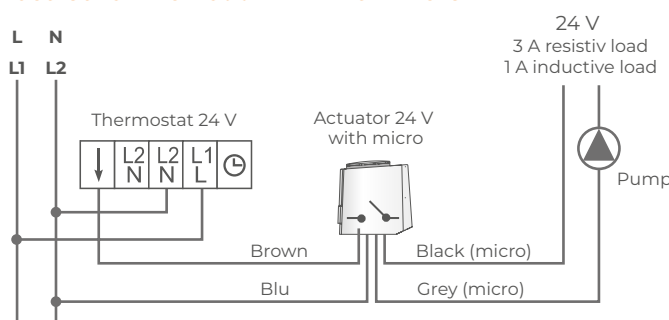

Electrical connection

Electrothermic head 230 V

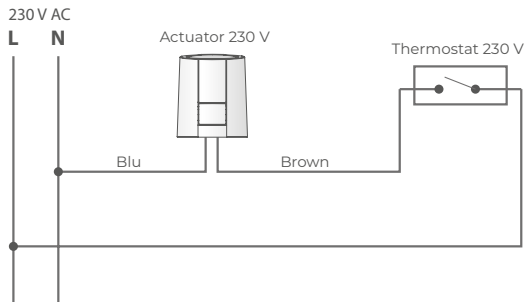

Electrothermic head 230 V with micro

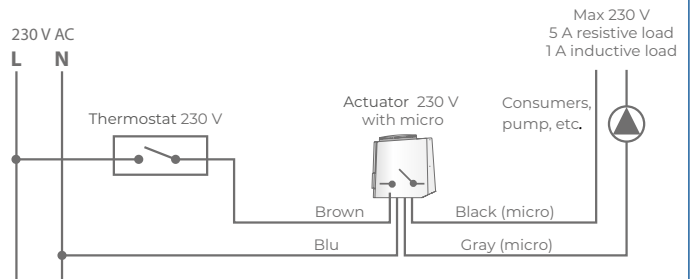

Air Trap

The air separator is made of brass, and it is used to collect the air that accumulates in the hydraulic circuit so that it can be eliminated. It is a necessary component in b!klimax and b!klimax+ systems, but it is recommended also in the other systems. FF (female - female) pipe connections.



With horizontal connections

FLOW RATE	SURFACE	SIZE	CODE
1.9 m ³ /h	up to 60 m ²	Ø 3/4"	6440020
2.6 m ³ /h	up to 85 m ²	Ø 1"	6440025
5.3 m ³ /h	up to 175 m ²	Ø 1 1/4"	6440032
6.3 m ³ /h	up to 210 m ²	Ø 1 1/2"	6440040
9.0 m ³ /h	up to 300 m ²	Ø 2"	6440050

With vertical connections

FLOW RATE	SURFACE	SIZE	CODE
1.9 m ³ /h	up to 60 m ²	Ø 3/4"	6440021
2.6 m ³ /h	up to 85 m ²	Ø 1"	6440026

Hygroscopic plug for air trap 6440055

Operating principle

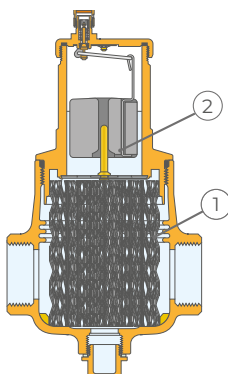

The air separator uses the combined action of several physical principles. The active part consists of an assembly of concentric metal mesh surfaces (1). These elements create the whirling movement required to facilitate the release of micro-bubbles and their adhesion to these surfaces.

The bubbles, fusing with each other, increase in volume until the hydrostatic thrust is such as to overcome the adhesion force to the structure. They rise towards the top of the unit from which they are released through a float-operated automatic air release valve (2). It is designed in such a way that the direction of the fluid flows makes no difference.



Pre-insulated Ø 20 mm pipe

PB pipe with oxygen barrier according to DIN 4726 EN 12319-2, Ø 20 mm, pipe insulation made of expanded polyethylene, thickness 6 mm. Reaction to fire class: BL-s2,d0. It is used to connect distributors with b!klimax manifolds.

DIAMETER	COLOR	PACKAGE	CODE
20 mm	red	roll 50 m	6200020
20 mm	blu	roll 50 m	6201020

Application field	CLASS 4	For use with hot and cold water (Tmax 60 °C)
	CLASS 5	For use with hot and cold water (Tmax 80 °C)

Outside diam. (mm)	Thickness (mm)	Weight (g/m)	CLASS 4 (bar)	CLASS 5 (bar)	Water content (l/m)
20	2	120	8	8	0,201

Pipe characteristics	Value	Unit	Standard
Standard			DIN 16968
Oxygen tightness	≤ 0.32	mg O ₂ / (m ² ·d)	DIN 4726
Degree of cross-linking	≥ 70	%	
Density	0.920	g/cm ³	ISO 1183
Thermal expansion coefficient at 20 °C	1.3 · 10 ⁻⁴	m/(m·K)	
Thermal conductivity	0.22	W/(m·K)	
Softening temperature	> 130	°C	
Elongation at break a 20 °C	> 300	%	ISO 8986-1
Ultimate Tensile Stress at 20 °C	19	MPa	ISO 8986-2
Roughness factor	0.0005		

Pipe insulation characteristics	Value	Unit	Standard
Thickness	6	mm	
Density	0.03 ÷ 0.05	g/cm ³	ISO 1183
Temperature range	-45 / +95	°C	
Thermal conductivity at 40 °C	0.039	W/(m·K)	
Thermal conductivity at 0 °C	0.033	W/(m·K)	
Water vapour permeability	> 5000		
Reaction to fire (Euroclass)	BL-s1, d0		EN 13501-1



Pre-insulated PB pipe Ø 6 mm

PB Ø 6 mm pipewith oxygen barrier according to DIN 4726 EN 12319-2, pipe insulation made of expanded polyethylene, reaction to fire class BL -s1, d0, thickness 6 mm. It is used to connect b!klimax+ and Quadrotto panels to the distributors.

DIAMETER	CODE
6 mm	6210006

Application field	CLASS 4	For use with hot and cold water (Tmax 60 °C)
	CLASS 5	For use with hot and cold water (Tmax 80 °C)

Outside diam. (mm)	Thickness (mm)	Weight (g/m)	CLASS 4 (bar)	CLASS 5 (bar)	Water content (l/m)
6	1	15.4	10	10	0,013

Pipe characteristics	Value	Unit	Standard
Standard			DIN 16968
Oxygen tightness	≤ 0.32	mg O ₂ / (m ² ·d)	DIN 4726
Degree of cross-linking	≥ 70	%	
Density	0.920	g/cm ³	ISO 1183
Thermal expansion coefficient at 20 °C	1.3 · 10 ⁻⁴	m/(m·K)	
Thermal conductivity	0.22	W/(m·K)	
Softening temperature	> 130	°C	
Elongation at break a 20 °C	> 300	%	ISO 8986-1
Ultimate Tensile Stress at 20 °C	19	MPa	ISO 8986-2
Roughness factor	0.0005		

Pipe insulation for Ø 6 mm pipe

Closed-cell elastomeric foam insulating sleeve, smooth on the surface, for thermal insulation of PB Ø 6 mm pipe. Thickness 6 mm.



DIAMETER	CODE
6 mm	6320010

Pipe insulation characteristics	Value	Unit	Standard
Thickness	6	mm	
Density	0.03 ÷ 0.05	g/cm ³	ISO 1183
Temperature range	-45 / +95	°C	
Thermal conductivity at 40 °C	0.039	W/(m·K)	
Thermal conductivity at 0 °C	0.033	W/(m·K)	
Water vapour permeability	> 5000		
Reaction to fire (Euroclass)	BL-s1, d0		EN 13501-1



PE-RT Ø 8 pipe

PE-RT Ø 8 mm pipe with oxygen barrier according to DIN 4726 DIN EN ISO 21003-2, thickness 1 mm. It is used to connect b!klimax+ panels with the distributors.

DIAMETER	CODE
8 mm	6210018

PE-RT pipe characteristics

Application field		CLASS 4	For use with hot and cold water	T _{max} 70 °C	Pressure 8 bar
		CLASS 5	For use with hot and cold water	T _{max} 90 °C	Pressure 6 bar
Outside diam. (mm)	Thickness (mm)	Weight (g/m)		Water content (l/m)	
8	1	22		0.028	



Insulation for PE-RT pipe

Insulation for PE-RT Ø 8 mm pipe made of expanded polyethylene, thickness 6 mm. Reaction to fire class: BL -s1, d0.

DIAMETER	CODE
8 mm	6320008



Biocida XR40

This sanitiser provides protection for surface heating and cooling systems against bacterial and fungal contamination. Such contamination can cause blockages in some parts of the installation, for example in the pipes, manifolds, valves or heat exchanger. Non-corrosive substance, easy and quick to dose. Biocida XR40 is compatible with Inhibitor XR20, and they shall be both used at first fill of the radiant system in the primary circuit.

SIZE	CODE
3 liters	1091301

Dosage	Application instructions
<p>BIOCIDA XR40 should be dosed at 1% of the water volume, i.e. 1 litre per 100 litres of water contained in the system. The 3-litre pack satisfies a typical civil heating system: 80-140 m² house, underfloor heating and/or radiators.</p>	<p>For an empty system introduce the product at any point of it before loading water. For a full system, use a dosing device to inject BIOCIDE XR40 in any access point of the system.</p> <p>Permanent treatment: leave in the system.</p>



Inibitor XR20

The inhibiting treatment provides protection for heating systems against corrosion. It can be used in installations with aluminium components, and it is suitable for any kind of installation.

SIZE	CODE
3 liters	1091105
10 liters	1091111

Dosage	Application instructions
<p>INIBITOR XR20 should be dosed at 2% of the water volume, i.e. 2 litres per 100 litres of water contained in the system. The 3-litre pack satisfies a typical civil heating system: 15- 25 kW boiler, 80-140 m² house, floor heating system and/or radiators. For larger systems, 10 litre packs can be used. An excess of product does not cause any issues.</p>	<p>For an empty system, introduce the product at any point in the system before filling with water. For a full system, use a dosing device to inject INIBITOR XR20 in any access point of the system.</p> <p>Permanent treatment: leave in the system.</p>



***Underfloor radiant
systems
with low thermal
inertia***





Innovation, with high performance

Underfloor heating systems with low thermal inertia are characterised by their ability to respond quickly to the climatic demands of the room in which they are installed, as the floor quickly reaches the desired temperature. Thus it is possible to always obtain the right indoor comfort and optimise energy consumption.

This particular characteristic makes low thermal inertia systems an ideal solution for any type of building and in particular for contemporary ones characterised by airtight envelopes and low thermal requirements.

Thanks to their very low thickness, they are also ideal for building renovations where the floor space available for the system is limited.

Available in a wide range of thicknesses, weights and materials, they can meet a variety of design and installation needs, reduce running costs and provide a pleasant, healthy and quiet climate all year round.

THE ADVANTAGES OF UNDERFLOOR SYSTEMS WITH LOW THERMAL INERTIA:



***IDEAL FOR RENOVATIONS AND
CONTEMPORARY BUILDINGS***



***SMALL FOOTPRINT AND
LOW WEIGHT***



***LOW THERMAL
THERMAL***



***HEATING AND COOLING
IN A SINGLE SOLUTION***



***COMFORT AND
ENERGY SAVING***

■ HIGH PERFORMANCE AND FAST RESPONSE FOR ALL BUILDINGS

Low-thickness systems for new buildings

In modern buildings characterised by hermetically sealed and insulated envelopes, it is increasingly important to use systems with high thermal responsiveness, which are able to follow the sudden changes in the internal thermal load, adapting the temperature of the rooms to the need for comfort.

In the case of buildings characterised by large glass surfaces, for example, it can happen that in mid-season, when the sun is not yet high above the horizon, there is a high heat input that causes a sudden increase in the indoor temperature. The same increase could also be generated in the presence of significant internal endogenous loads.

In these cases, the high inertia system, if poorly managed, would not be able to satisfy the thermal load (solar+endogenous) thus bringing the rooms to temperatures higher than the comfort limit.

The ideal, in these cases, is to have a system that is able in a few minutes to adapt its parameters to the variation of the thermal load, constantly guaranteeing the best conditions of comfort in the rooms.

The graphs below show the speed at which the systems start up and shut down, highlighting the different reactivity of traditional and low thermal inertia systems.

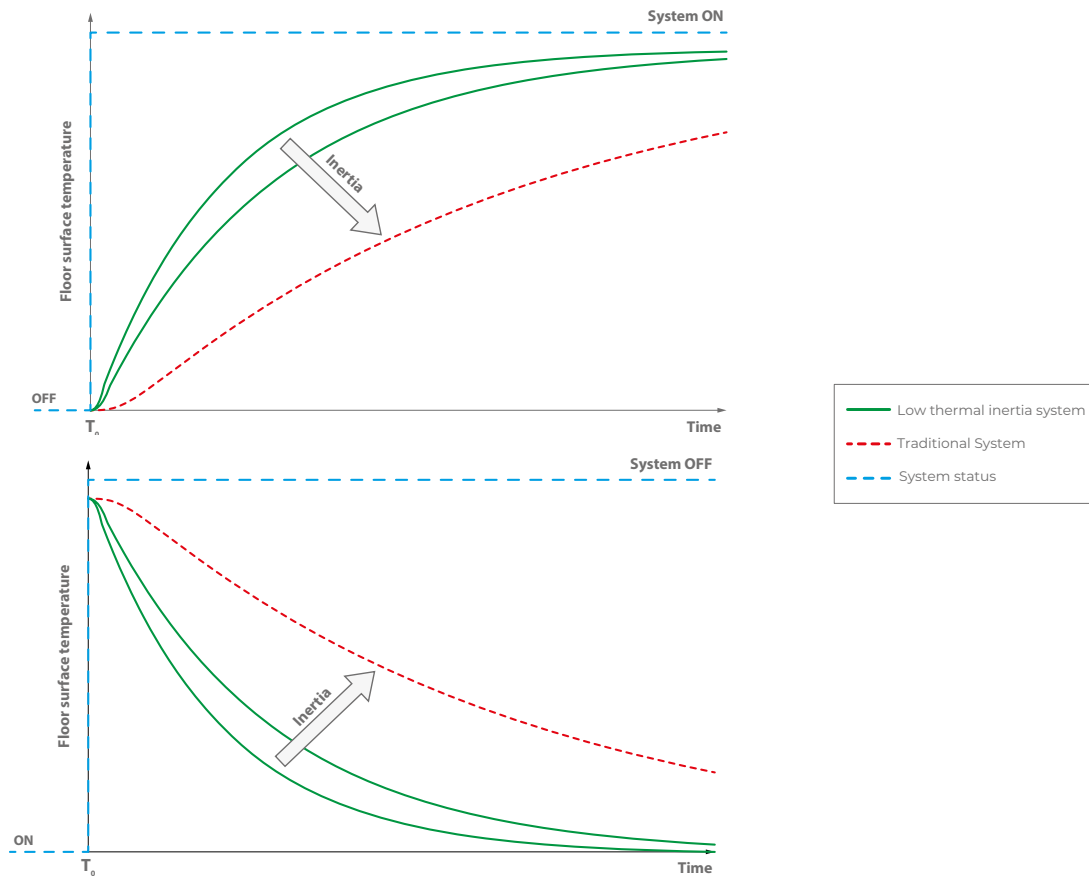

Low-thickness systems for renovations



In buildings subject to renovation or extraordinary maintenance, the radiant floor system with reduced thickness and low thermal inertia is the ideal solution.



Often, in fact, interventions on existing buildings, lead to encounter situations that hinder the installation of panels for traditional radiant underfloor systems, such as in the case of:

- buildings in which there are not the necessary heights for the installation of standard systems (the latter generally require from 7.5 to 13 cm excluding flooring)
- very old houses with subfloor that are not dimensioned to support the weight of a standard system (about 120 kg/m²)

In these circumstances, the low inertia and reduced thickness systems, thanks to their small footprint and reduced weight, make it possible to benefit of all the advantages offered by a floor system, even in contexts characterised by considerable structural constraints.

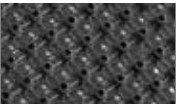
SYSTEM SELECTION BY THICKNESS

Concrete systems		Panel thickness [mm]	Pipe [mm]	Base [mm]	Stud [mm]	Concrete [mm]	Total [mm]
Rapid US pag. 58		3	PE-RT Ø 17	3	-	10	30
Neo Super D17 page 64		15	PE-Xa Ø 17	15	18	10	43
		24		24	19	10	53
		34		34	18	10	62
Super D page 70		10	PB Ø 12	10	16	10	36
Zero Level AD page 76		18	PB Ø 12	0	18.5	5	24

Dry systems		Panel thickness [mm]	Pipe [mm]	Total thickness [mm]	Allocator of load [mm]	Total [mm]
e-Dry Tech page 82		25	Multilayer Ø 16	25	4	29
e-Dry Evo page 88		25	Multilayer Ø 16	25	9	34

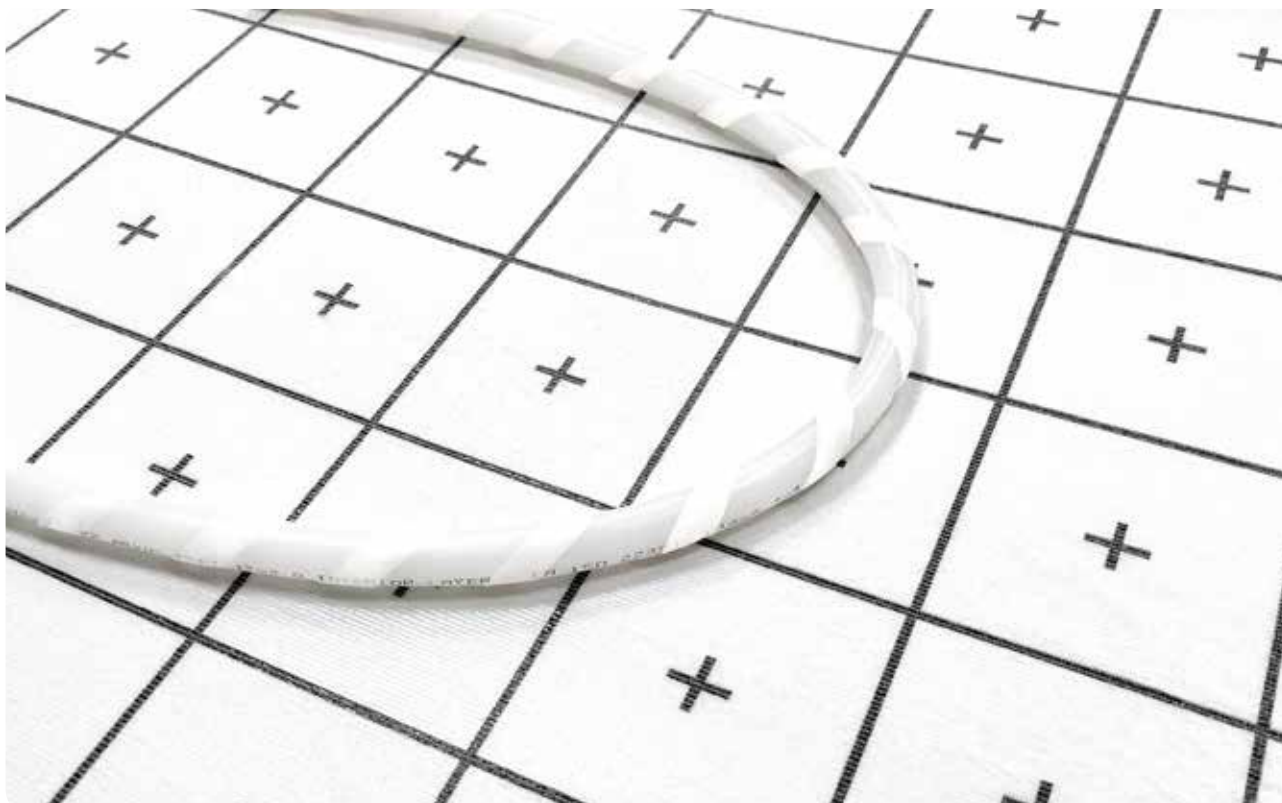

Rapid US is an underfloor heating and cooling system with low thermal inertia and reduced thickness, characterised by \varnothing 17 mm PE-Xa pipe anchored to an insulated base through a hook-and-loop fastening system and embedded in the special lowered screed.

Thanks to the overall thickness of only 30 mm, it is ideal for building renovations where the space available for the installation is limited.

Moreover, its low thermal inertia makes it highly suited to contemporary low-energy buildings which require systems capable of responding to changes in the internal thermal loads quickly and efficiently.

The system's core element is the Rapid US panel made of plastic material coated with a non-woven fabric sheet screen-printed with a 50 mm pitch, which functions as a support for the PE-RT pipe. The latter, equipped with a system of hooks, attaches to the panel without the aid of clips.

The panel consists of sheets folded in the middle like a book, measuring 2x1 m, which have compact overall dimensions and are easy to transport, due to their low bulk and light weight.

The system is completed by the open support elbow, the manifold, the Slim 5 perimeter belt, the paper adhesive tape for sealing between panels and the Isocoll 160 adhesive for gluing the panel to the substrate.

FEATURES

- Low thickness and low thermal inertia system
- Ideal for renovations and contemporary buildings
- Tear-off fastening of Rapid PE-RT pipe \varnothing 17 mm
- Quick and easy to install



SECTION AND DIMENSIONS

- 1 Skirting board
- 2 Flooring
- 3 Concrete
- 4 Rapid PE-RT pipe Ø 17 mm
- 5 SLIM 5 perimeter belt
- 6 Rapid US panel
- 7 Stable, solid and planar subfloor

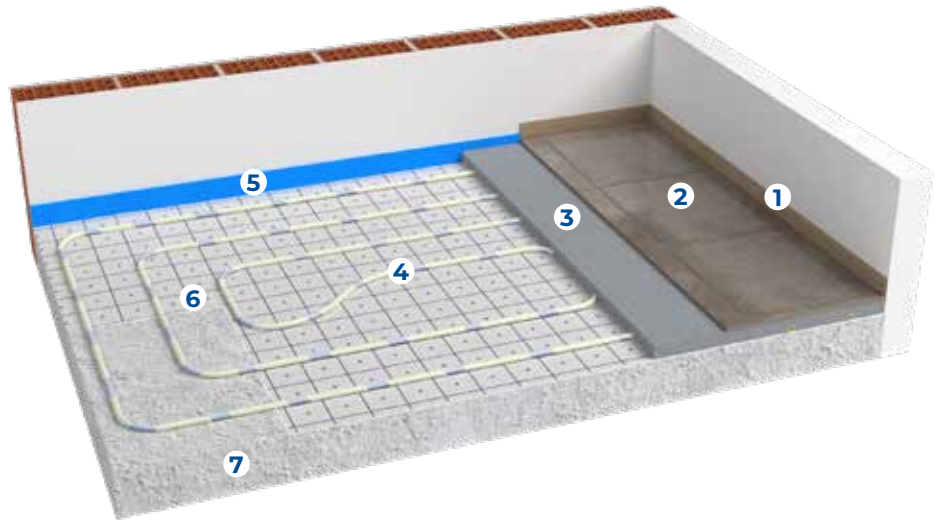

Weight of the system calculated with 10 mm level above pipe

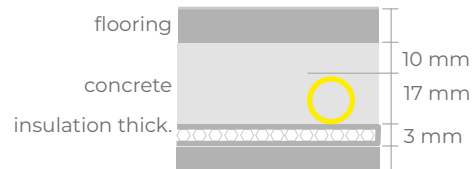

Indicative quotas

Panel thickness	3 mm
Quote with Tiles - Parquet flooring	4.0 - 5.0 cm
Quote with Marble - Blockboard flooring	5.0 - 6.0 cm

Suggested Screeds

PRODUCER	SPECIAL LEVELLING SCREED
KNAUF	NE 425 Autolivellina
KNAUF	NE 499 Superlivellina
LATERLITE	PaRis SLIM
LATERLITE	PaRis FLUID for screed thickness above pipe ≥ 20 mm
MAPEI	Novoplan Maxi for screed thickness above pipe ≥ 20 mm

Note: please refer to the Rapid US installation manual and the data sheets of the suggested products.

Installation notes

- If the floor is in direct contact with the ground (i.e. without a sanitary void or insulating sheathing), provide adequate waterproofing and subsequent levelling concrete
- Check the suitability of the substrate: flatness, surface suitable for gluing
- Check the available heights (minimum thickness of screed: 10 mm above the studs)
- Proceed with the installation of the perimeter belt
- After carefully cleaning the substrate by removing dust and residues, glue the panels with the appropriate adhesive
- Complete the system by laying the pipe as stated in the project
- Test the system and leave it under pressure until all subsequent installation and works are completed
- For the construction of the special screed, follow the screed manufacturer's installation instructions

Note: Please refer to the installation manual for more information.

PRODUCTS THAT COMPOSE THE SYSTEM

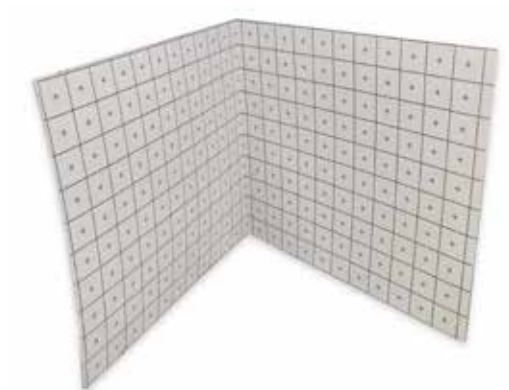

RAPID US Panel

Honeycomb polypropylene panel covered with a TNT sheet appropriately screen-printed in a 50 mm pitch chequered pattern, which serves as a support for the tubing with a suitable hook system. The panel is presented in sheets folded in two with useful dimensions of 2x1 m and a thickness of 3 mm.

SIZE	THICKNESS	CODE
2000x1000 mm	3 mm	1201007

Panel characteristics	15	U.M.
Necessary length	2000	mm
Necessary width	1000	mm
Total thickness	3	mm
Thermal resistance	0,071	(m ² ·K)/W
Maximum applicable surface load	≤ 5	kPa
Fire reaction (DIN EN 13501-1)	E	
Panel weight	1.9	Kg
Packaging	20	m ²



Rapid PE-RT Pipe Ø 17

RDZ 17-13 polyethylene pipe with EVOH oxygen diffusion barrier which complies with DIN 4726. It consists in 5 layers PE-RT/EVOH/PE-RT ensuring outstanding flexibility & easy handling. A micro-interlocking band is helically wound around the pipe.

SIZE	TYPE	CODE
Ø 17-13 mm	PE-RT	1013890

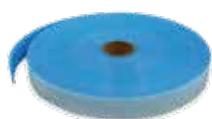

Slim 5 Perimeter Belt

The edge insulation Slim 5 absorbs floor expansions and acts as thermo-acoustic insulation for the walls.

SIZE	CODE
5x50 mm	1200050



Paper adhesive tape

Paper adhesive tape for fixing the synthetic fibre load divider.

SIZE	CODE
50 m	1202165



Open Elbow

Open Ø 17 elbow made of plastic material. It is used to support the pipes near the manifolds vertically and to protect them from any damage.

SIZE	CODE
Ø 17 mm	1130517



Isocoll ECO 6051

A high-performances single component lilyl-terminated adhesive.
Consumption: one cartridge for every 3 m².

SIZE	CODE
290 ml	1111113

Tips for material calculation

Mandatory product	Requirements
Rapid US panel	Area to be covered +5%
Rapid PE-RT pipe Ø 17	Based on the average laying pitch. Total = area / pitch [m ² /m]
Slim 5 perimeter belt	1 metre per m ²
Open elbow Ø 17	2 for each circuit
Isocoll ECO 6051	1 can each 3 m ² approx

Optional product	Requirements
Inhibitor XR20	2% of WHOLE water content
Biocide XR40	1% of WHOLE water content

Manifolds, electrothermal heads, accessories and optional products (from page 160).

Note: The requirements in the table are indicative. Please refer to the construction project for confirmation.

THERMAL OUTPUT OF THE SYSTEM

Thermal output in heating

Input data			
Piper external diameter	d_o	0.017	m
Pipe wall thickness	s_R	0.002	m
Pipe heat conductivity	λ_R	0.40	W(m·k)

K_H [$m^2 \cdot k$]															
$R_{\lambda,B}$ [$m^2 \cdot k/W$]															
T cm	0.01	0.02	0.03	0.04	0.05	0.06	0.07	0.08	0.09	0.10	0.11	0.12	0.13	0.14	0.15
5	7,456	6,919	6,462	6,064	5,713	5,401	5,122	4,871	4,643	4,436	4,246	4,072	3,912	3,764	3,626
10	6,000	5,612	5,288	5,007	4,756	4,531	4,326	4,140	3,970	3,813	3,669	3,535	3,411	3,295	3,187
15	4,747	4,406	4,155	3,948	3,768	3,607	3,463	3,331	3,209	3,097	2,993	2,897	2,807	2,722	2,643

$R_{\lambda,B}$: Heat conduction resistance of the floor covering
 T: Pipe spacing
 K_H : Equivalent thermal transmission coefficient

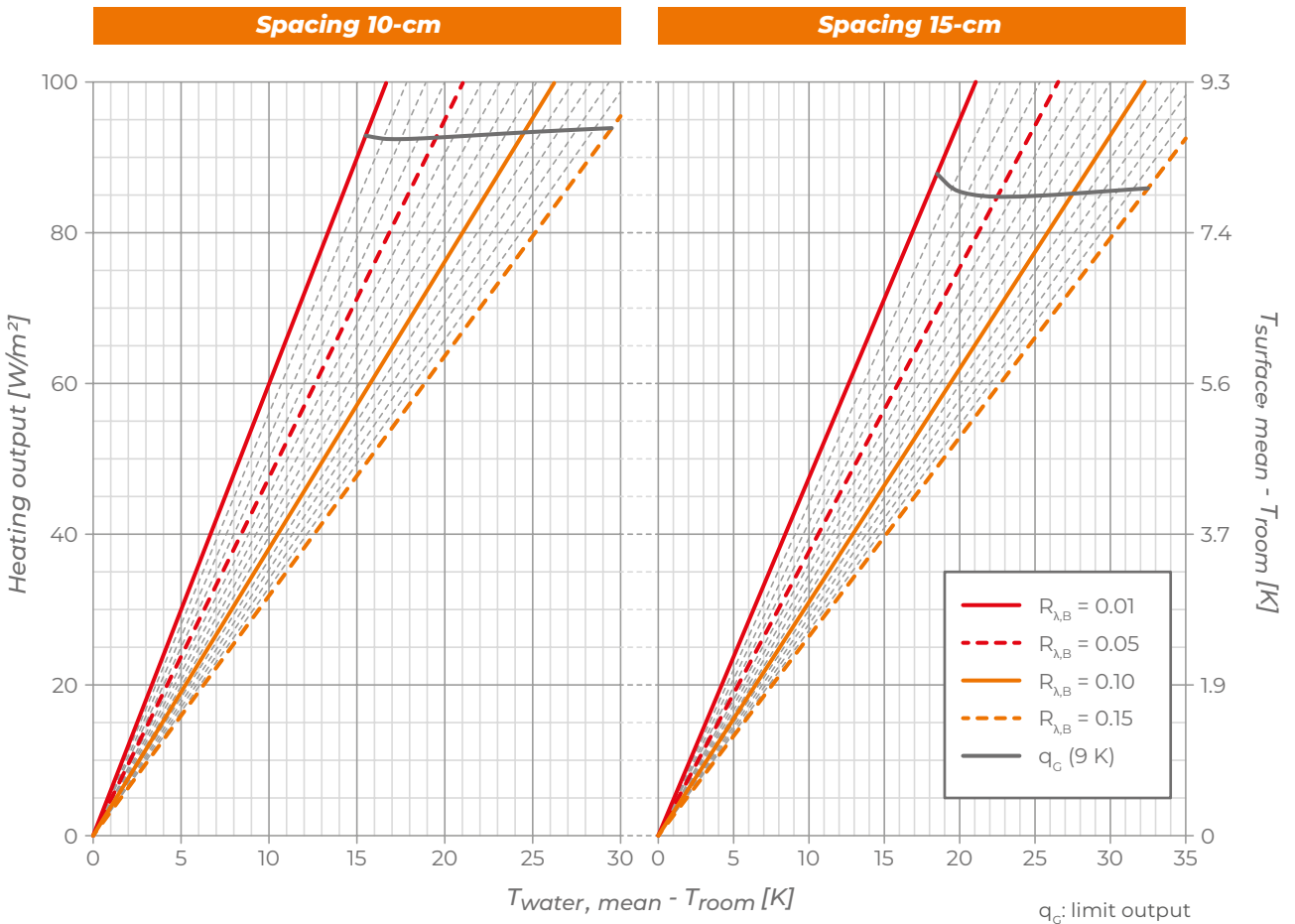

Thermal output in cooling

Input data			
Piper external diameter	d_o	0.017	m
Pipe wall thickness	s_R	0.002	m
Pipe heat conductivity	λ_R	0.40	W(m·k)

K_H [$m^2 \cdot k$]															
$R_{\lambda,B}$ [$m^2 \cdot k/W$]															
T cm	0.01	0.02	0.03	0.04	0.05	0.06	0.07	0.08	0.09	0.10	0.11	0.12	0.13	0.14	0.15
5	5,111	4,853	4,624	4,416	4,227	4,054	3,895	3,747	3,611	3,484	3,366	3,256	3,153	3,056	2,965
10	4,374	4,163	3,982	3,819	3,671	3,536	3,410	3,293	3,184	3,083	2,988	2,898	2,814	2,735	2,660
15	3,617	3,406	3,251	3,121	3,007	2,903	2,809	2,721	2,640	2,564	2,492	2,425	2,362	2,302	2,245

$R_{\lambda,B}$: Heat conduction resistance of the floor covering
 T: Pipe spacing
 K_H : Equivalent thermal transmission coefficient

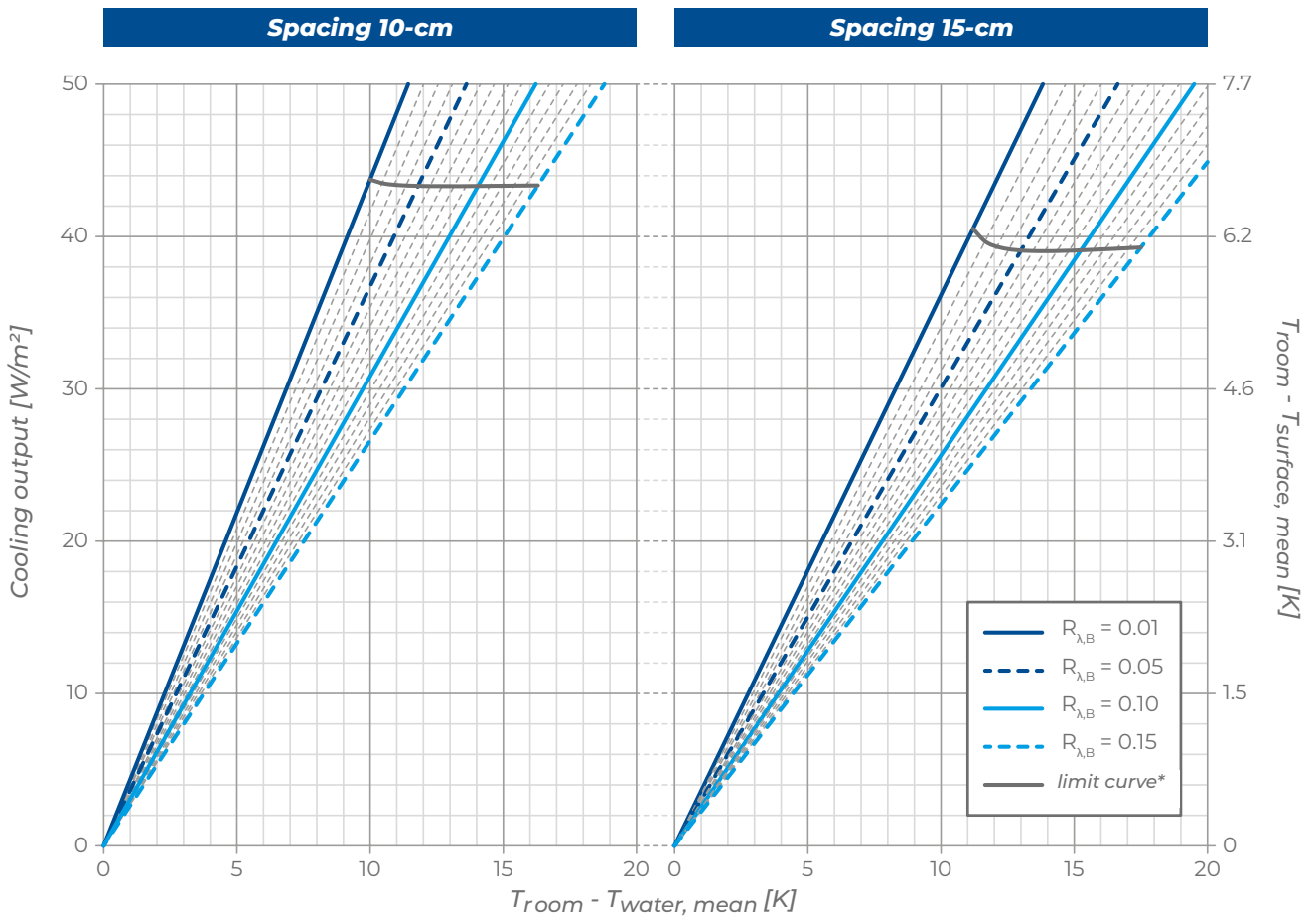

*valid only for room temperature = 26 °C

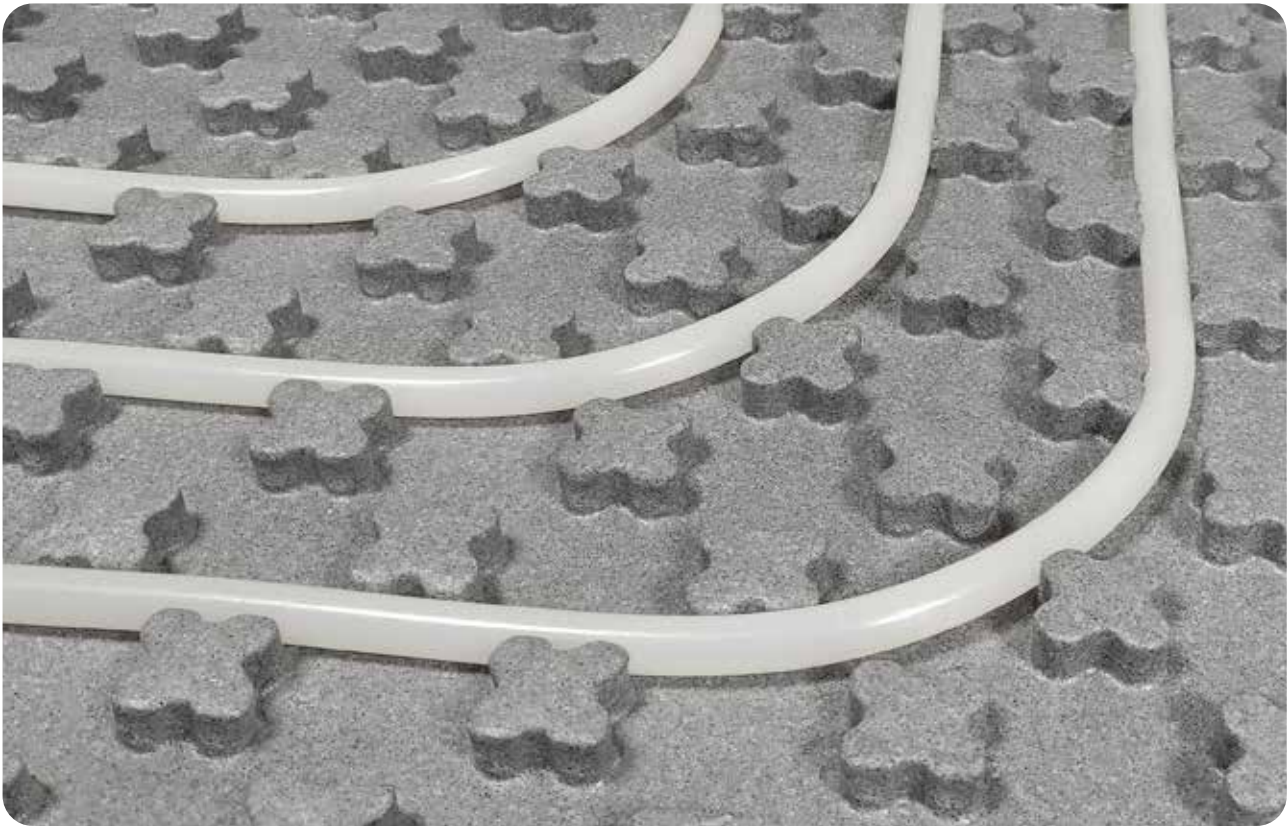

Neo Super D17 is an underfloor heating and cooling system with low thermal inertia and reduced thickness, characterised by \varnothing 17 mm PE-Xa pipe anchored to an insulated base and embedded in the special lowered screed.

Thanks to its small dimensions, it is ideal for building renovations where the space available for the installation is limited. The low thermal inertia also makes it particularly suitable for contemporary buildings which, being low energy users, require rapid responsiveness to varying of thermal loads.

The central element of the system is the Neo Super D17 studded panel made of sintered expanded polystyrene with graphite, in compliance with UNI EN 13163 and characterised by very high mechanical resistance. Designed to be glued to the substrate using a special polyurethane adhesive, it can also be placed on top of existing flooring, avoiding its demolition.

Available in thicknesses of 15, 24 and 34 mm, thanks to the use of 17 mm diameter pipe, it allows a reduced number of radiant circuits and enables large areas to be served with a single manifold.

The system is completed by RDZ Tech PE-Xa pipe \varnothing 17 mm in cross-linked high-density polyethylene, equipped with anti-oxygen barrier according to DIN 4726, the open support elbows, the manifold, the Slim 9 perimetric belt and the adhesive Isocoll 160 for gluing the panel to the laying surface.

FEATURES

- Low thickness and low thermal inertia system
- PE-Xa \varnothing 17 mm pipe
- Possibility of gluing the panel to the existing flooring
- Ideal for renovations and contemporary buildings



SECTION AND DIMENSIONS

- 1 Skirting board
- 2 Flooring
- 3 Concrete
- 4 PE-Xa pipe Ø 17 mm
- 5 Perimeter belt
- 6 Neo Super D17 panel
- 7 Stable, solid and planar subfloor

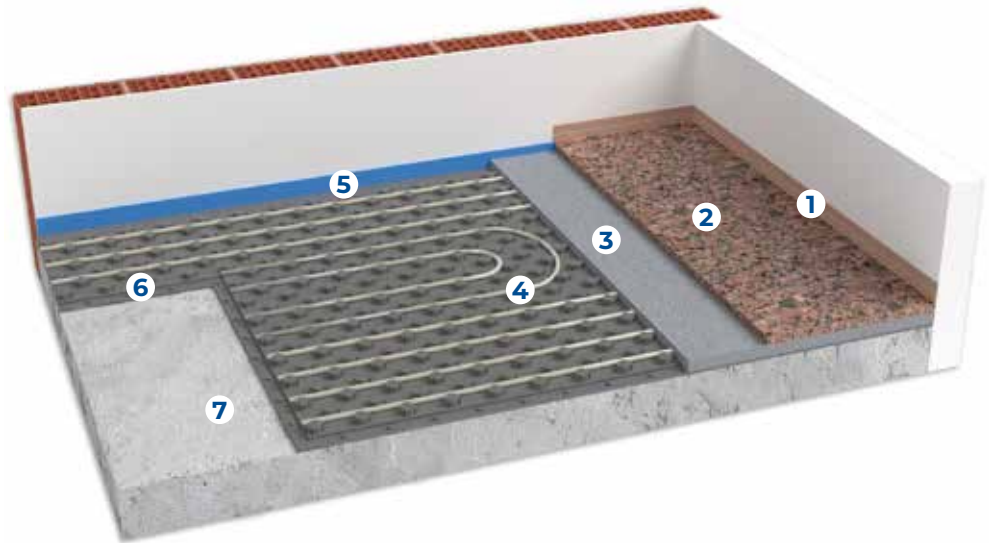

Weight of the system calculated with 10 mm level on top of the studs

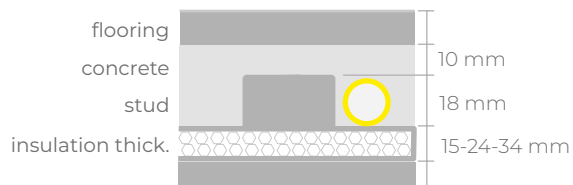

Indicative quotas

Panel thickness	15 mm	24 mm	34 mm
Quote with Tiles - Parquet flooring	5.3 - 6.3 cm	6.3 - 7.3 cm	7.3 - 8.3 cm
Quote with Marble - Blockboard flooring	6.3 - 8.3 cm	7.3 - 9.3 cm	8.3 - 10.3 cm

Suggested Screeds

PRODUCER	SPECIAL LEVELLING SCREED
KNAUF	NE 425
KNAUF	NE 499
LATERLITE	PaRis SLIM
LATERLITE	PaRis FLUID for screed thickness above stud ≥ 20 mm

Note: please refer to the Neo Super D17 installation manual and the data sheets of the suggested products.

Installation notes

- If the floor is in direct contact with the ground (i.e. without a sanitary void or insulating sheathing), provide adequate waterproofing and subsequent levelling concrete
- Check the suitability of the substrate: flatness, surface suitable for gluing
- Check the available heights (minimum thickness of screed: 10 mm above the studs)
- Proceed with the installation of the perimeter belt
- After carefully cleaning the substrate by removing dust and residues, glue the panels with the appropriate adhesive
- Complete the system by laying the pipe as stated in the project
- Test the system and leave it under pressure until all subsequent installation and works are completed
- For the construction of the special screed, follow the screed manufacturer's installation instructions

Note: Please refer to the installation manual for more information.

PRODUCTS THAT COMPOSE THE SYSTEM



Neo Super D17 Panel

Grooved insulation panel made of sintered expanded polystyrene with graphite complying with UNI EN 13163. High compressive strength (500 kPa). These panels have a tongue along the perimeter to connect them for proper combination. They have a moulded surface with reliefs of 18 mm so that the 17-mm pipe can be fitted into the tabs of the panel. Pipe spacing: 5 cm.

SIZE	THICKNESS	CODE
1400x800 mm	15 mm	1500315E
1400x800 mm	24 mm	1500324E
1400x800 mm	34 mm	1500344E

Panel characteristics	Symbol	15	24	34	Unit	Standard
Necessary length	L3	1400			mm	UNI EN 13163:2017
Necessary width	W3	800			mm	
Total thickness	T2	33	42	52	mm	
Insulation base thickness		15	24	34	mm	
Equivalent thickness		20	29	39	mm	
Resistance to compression with 10% deformation	CS(10)	500			kPa	
Thermal conductivity 10 °C	λ_D	0.030			W/(m·K)	
Thermal resistance	R_D	0.50	0.75	1.10	(m ² ·K)/W	
Water vapour diffusion resistance factor	μ (MU)	100 ÷ 160				
Water vapour permeability	δ	0.004 ÷ 0.007			mg/(Pa·h·m)	
Dimension stability 48h / 70°C	DS(70,-)	< 1			%	
Fire reaction		E			Euroclass	
Long-term water absorption by total immersion	WL(T)	≤ 5			%	
Limit of operating temperature		70			°C	
EPS panel weight		1150	1740	2440	g	
Specific heat	C	1450			J/kg·°k	
Class: EPS 500						
Declaration according to UNI EN 13163		EPS-UNI EN 13163:2017-L3-W3-T2-CS(10)500-WL(T)5-MU(100-160)				



RDZ Tech PE-Xa Pipe Ø 17 Interior Layer

RDZ Tech pipe Ø 17-13 made of high-density cross-linked polyethylene with the oxygen barrier between the PE-Xa layer and an outer layer made of PE, which ensures further protection during installation in the building site. The layers are combined thanks to a special glue. This pipe is produced according to DIN 16892 and DIN 4726 concerning oxygen permeability. This solution offers even and stable cross-links and constant characteristics over time. Natural colour

DIAMETER	ROLL	CODE
17-13 mm	240 m	1013840
17-13 mm	600 m	1013850

Note:
for further technical data see page 178



Slim 9 Perimeter Belt

The edge insulation Slim 9 absorbs floor expansions and acts as thermo-acoustic insulation for the walls.

SIZE	CODE
5x90 mm	1071100



Open Elbow

Open Ø 17 elbow made of plastic material. It is used to support the pipes near the manifolds vertically and to protect them from any damage.

SIZE	CODE
Ø 17 mm	1130517



Isocoll 160

One-component polyurethane adhesive. Moisture hardener with low viscosity, flexible in use. This solventless glue reacts to the moisture in the air and turns to a fine and restrained foam.

SIZE	CODE
500 gr	1111112

Tips for material calculation

Mandatory product	Requirements
Neo Super D17 panel	Area to be covered +5%.
RDZ Tech pipe PE-Xa Ø 17	Based on the average laying pitch. Total = area / pitch [m ² /m]
Slim 9 perimeter belt	1 metre per m ²
Open elbow Ø 17	2 for each circuit
Isocoll 160	1 bottle each 5 m ² approx
Optional product	Requirements
Inibitor XR20	2% of WHOLE water content
Biocide XR40	1% of WHOLE water content

Manifolds, electrothermal heads, accessories and optional products (from page 160).

Note: The requirements in the table are indicative. Please refer to the construction project for confirmation.

THERMAL OUTPUT OF THE SYSTEM

Thermal output in heating

Input data			
Piper external diameter	d_o	0.017	m
Pipe wall thickness	s_R	0.002	m
Pipe heat conductivity	λ_R	0.35	W(m·k)

K_H [m ² ·k]															
$R_{\lambda,B}$ [m ² ·k/W]															
T cm	0.01	0.02	0.03	0.04	0.05	0.06	0.07	0.08	0.09	0.10	0.11	0.12	0.13	0.14	0.15
5	7,456	6,919	6,462	6,064	5,713	5,401	5,122	4,871	4,643	4,436	4,246	4,072	3,912	3,764	3,626
10	6,000	5,612	5,288	5,007	4,756	4,531	4,326	4,140	3,970	3,813	3,669	3,535	3,411	3,295	3,187
15	4,747	4,406	4,155	3,948	3,768	3,607	3,463	3,331	3,209	3,097	2,993	2,897	2,807	2,722	2,643

$R_{\lambda,B}$: Heat conduction resistance of the floor covering
 T: Pipe spacing
 K_H : Equivalent thermal transmission coefficient

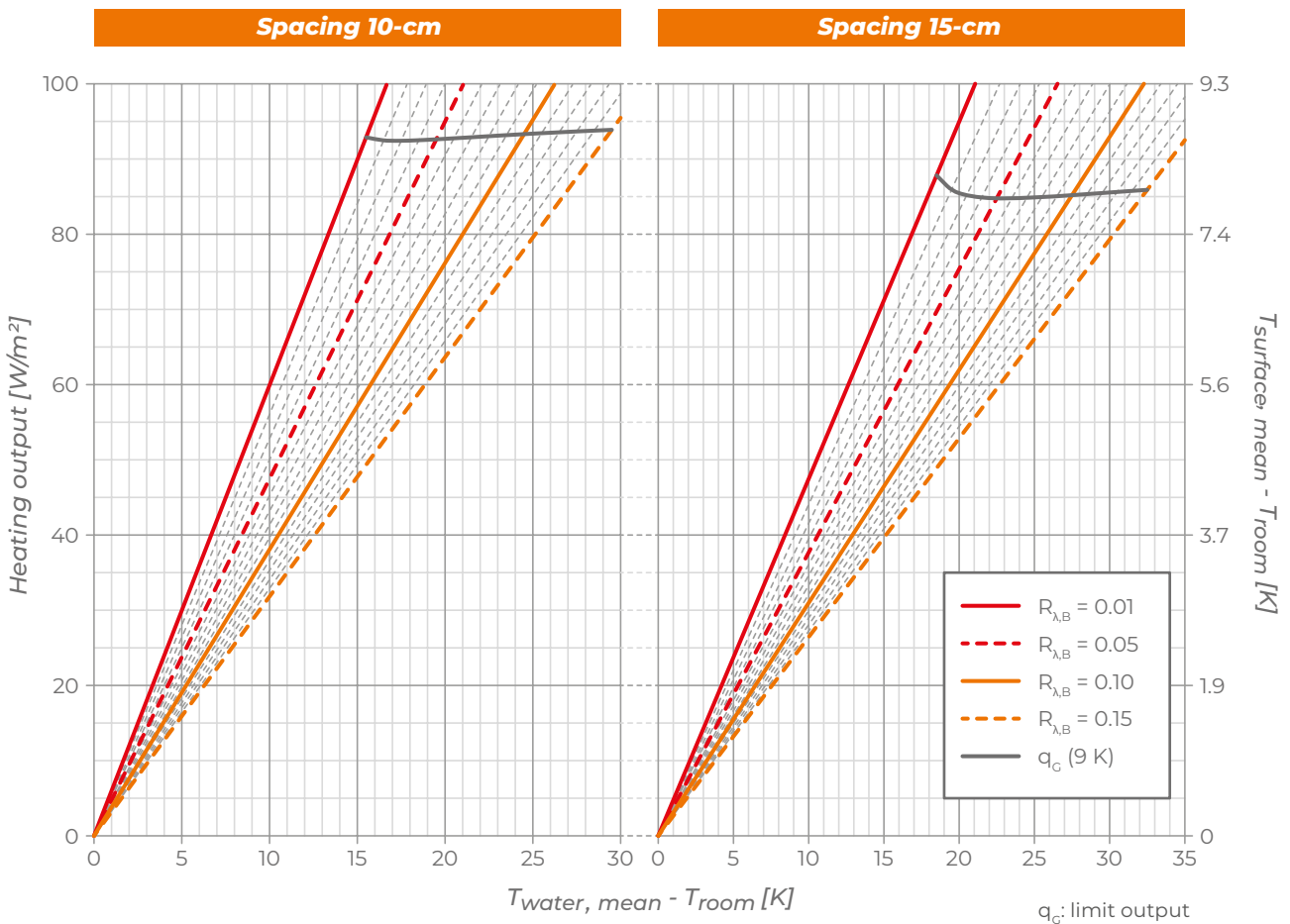

Thermal output in cooling

Input data			
Piper external diameter	d_o	0.017	m
Pipe wall thickness	s_R	0.002	m
Pipe heat conductivity	λ_R	0.35	W(m·k)

K_H [$m^2 \cdot k$]															
$R_{\lambda,B}$ [$m^2 \cdot k/W$]															
T cm	0.01	0.02	0.03	0.04	0.05	0.06	0.07	0.08	0.09	0.10	0.11	0.12	0.13	0.14	0.15
5	5,111	4,853	4,624	4,416	4,227	4,054	3,895	3,747	3,611	3,484	3,366	3,256	3,153	3,056	2,965
10	4,374	4,163	3,982	3,819	3,671	3,536	3,410	3,293	3,184	3,083	2,988	2,898	2,814	2,735	2,660
15	3,617	3,406	3,251	3,121	3,007	2,903	2,809	2,721	2,640	2,564	2,492	2,425	2,362	2,302	2,245

$R_{\lambda,B}$: Heat conduction resistance of the floor covering
 T: Pipe spacing
 K_H : Equivalent thermal transmission coefficient

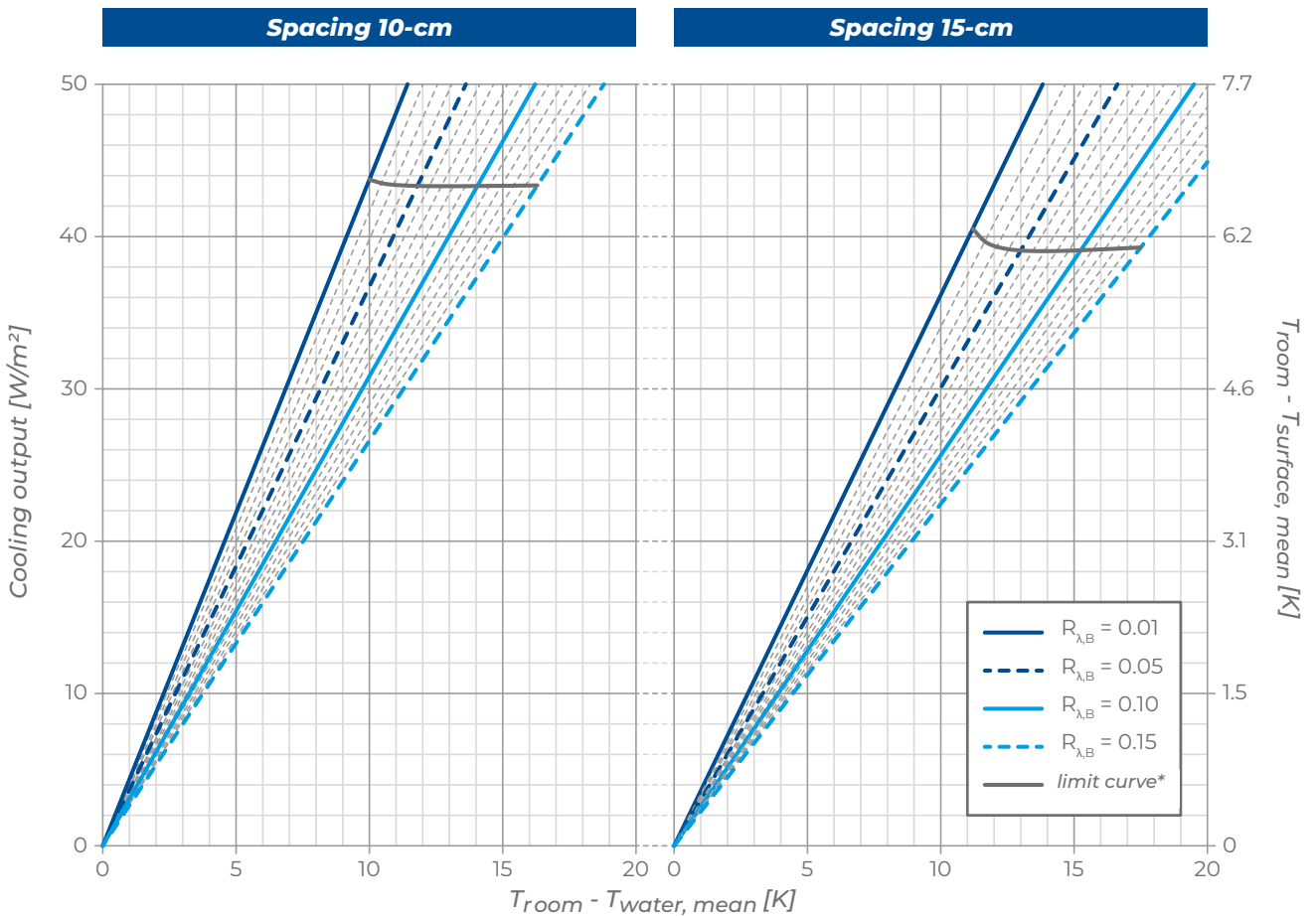

*valid only for room temperature = 26 °C

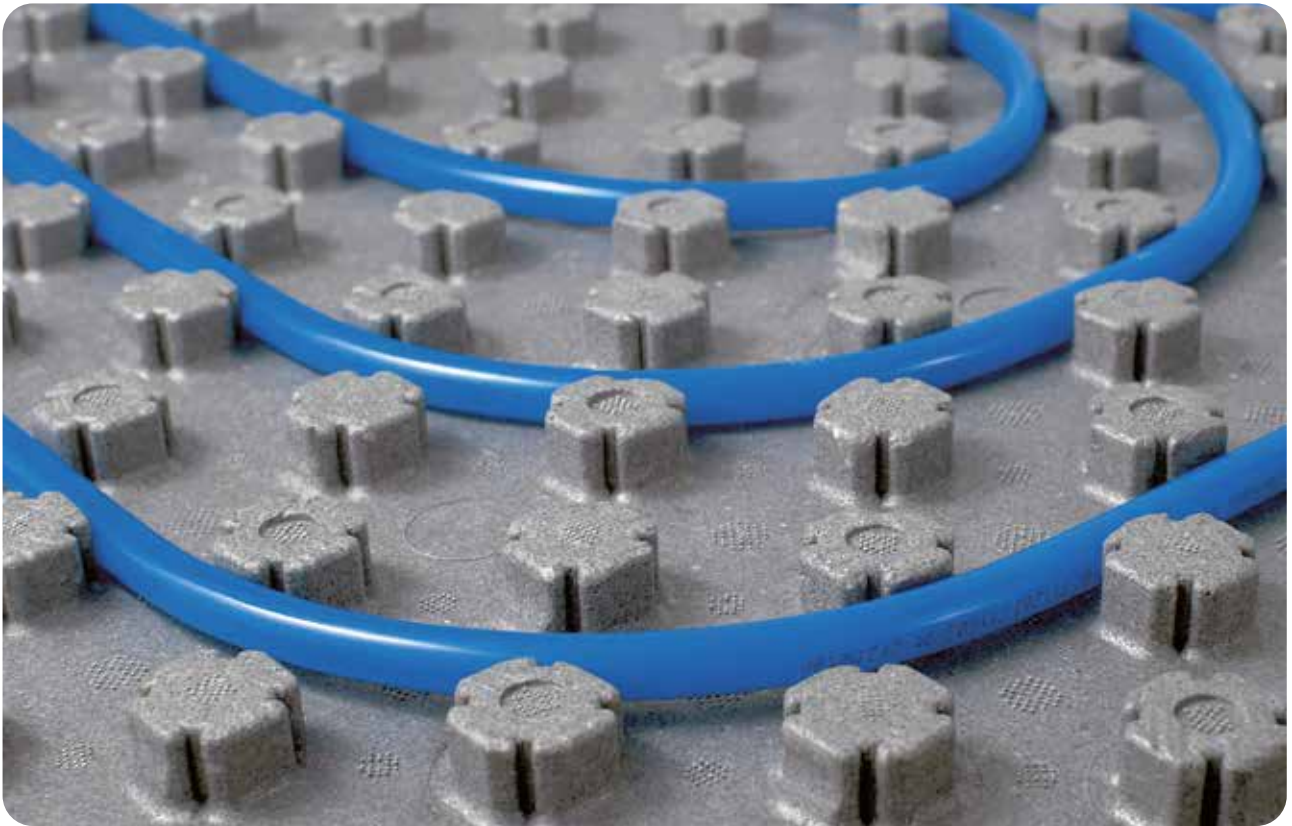

Super D is an underfloor heating and cooling system with low thermal inertia and low thickness, characterised by Ø 12 mm PB pipe anchored to an insulated base and embedded in the special lowered screed.

Thanks to its very small footprint, it is ideal for building renovations where the space available for the installation is limited. The low thermal inertia also makes it particularly suitable for contemporary buildings which, being low energy users, require rapid responsiveness to varying of thermal loads.

The central element of the system is the Super D studded panel made of sintered expanded polystyrene with graphite, in compliance with UNI EN 13163, characterised by extremely high mechanical resistance. Designed to be glued to the substrate using a special polyurethane adhesive, it can also be placed on top of the existing flooring, avoiding its demolition.

The system is completed by the RDZ Clima PB pipe Ø 12 mm with excellent flexibility to facilitate the installation of the circuits, the open support elbows, the manifold, the Slim 9 perimeteric belt and the adhesive Isocoll 160 for gluing the panel to the substrate.

FEATURES

- Lowered system, low thermal inertia
- PB Ø 12 mm pipe
- Possibility of gluing the panel to the existing flooring
- Ideal for renovations and contemporary buildings



SECTION AND DIMENSIONS

- 1 Skirting board
- 2 Flooring
- 3 Concrete
- 4 PB pipe Ø 12 mm
- 5 Perimeter belt
- 6 Super D panel
- 7 Stable, solid and planar subfloor

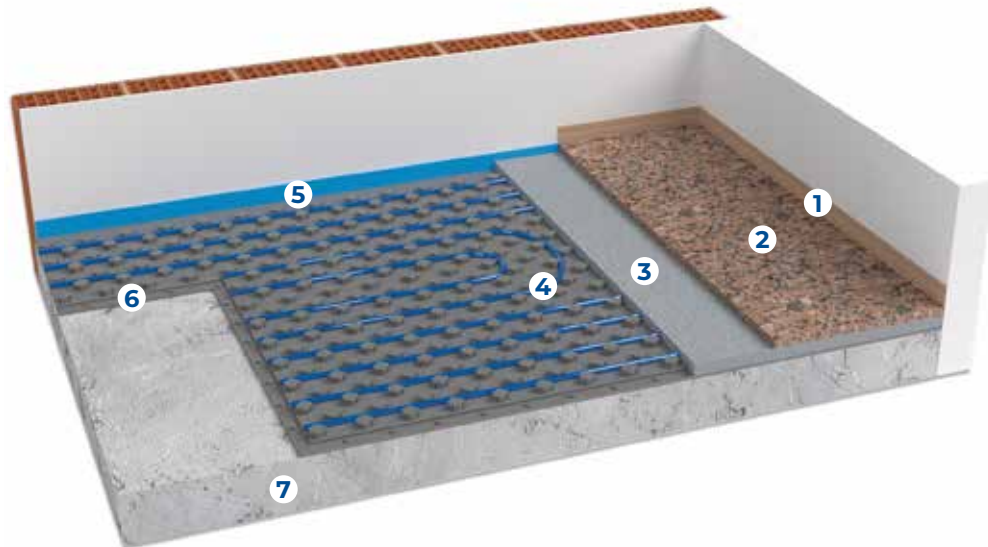

Weight of the system calculated with 10 mm level on top of the studs

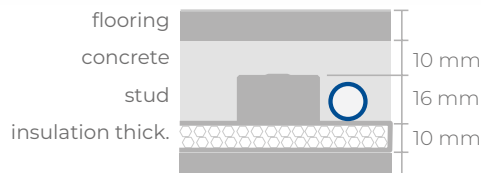

Indicative quotas (with 10 mm concrete)

Panel thickness	10 mm
Quote with Tiles - Parquet flooring	4.6 - 5.6 cm
Quote with Marble - Blockboard flooring	5.6 - 7.6 cm

Suggested Screeds

PRODUCER	SPECIAL LEVELLING SCREED
KNAUF	NE 425 Autolivellina
KNAUF	NE 499 Superlivellina
LATERLITE	PaRis SLIM
LATERLITE	PaRis FLUID for screed thickness above studs ≥ 20 mm
MAPEI	Novoplan Maxi for screed thickness above studs ≥ 20 mm

Note: please refer to the Super D installation manual and the data sheets of the suggested products.

Installation notes

- If the floor is in direct contact with the ground (i.e. without a sanitary void or insulating sheathing), provide adequate waterproofing and subsequent levelling concrete
- Check the suitability of the substrate: flatness, surface suitable for gluing
- Check the available heights (minimum thickness of screed: 10 mm above the studs)
- Proceed with the installation of the perimeter belt
- After carefully cleaning the substrate by removing dust and residues, glue the panels with the appropriate adhesive
- Complete the system by laying the pipe as stated in the project
- Test the system and leave it under pressure until all subsequent installation and works are completed
- For the construction of the special screed, follow the screed manufacturer's installation instructions

Note: Please refer to the installation manual for more information.

PRODUCTS THAT COMPOSE THE SYSTEM

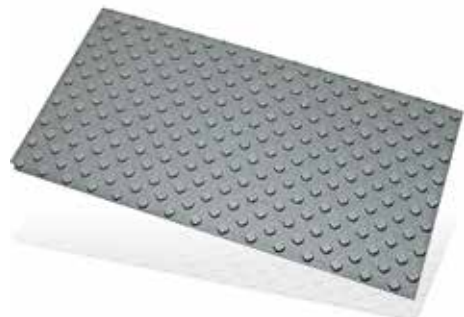

Super D Panel

Super D panel with studs made of waterproof sintered expanded polystyrene with graphite, produced in conformity with UNI EN 13163, with closed-cell structure and high compression strength (≥ 500 kPa). These panels have a tongue along the perimeter to connect them for proper combination. They have a moulded surface with reliefs of 16 mm so that the polybutylene pipes $\varnothing 12 \times 1.3$ mm can be fitted into the tabs of the panel at spacing of 4 cm or multiples.

SIZE	THICKNESS	CODE
1200x640 mm	10 mm	1500110

Panel characteristics	Symbol	10	Unit	Standard
Necessary length	L3	1200	mm	UNI EN 822
Necessary width	W3	640	mm	UNI EN 822
Total thickness	T2	26	mm	UNI EN 823
Insulation base thickness		10	mm	
Equivalent thickness		13.3	mm	UNI EN 1264/3
Resistance to compression with 10% deformation	CS(10)	≥ 500	kPa	UNI EN 826
Thermal conductivity 10 °C	λ_D	0.032	W/(m·K)	UNI EN 13163
Thermal resistance	R_D	0.30	(m ² ·K)/W	UNI EN 13163
Water vapour diffusion resistance factor	μ (MU)	40 ÷ 100		UNI EN 12086
Water vapour permeability	δ	0.006 ÷ 0.015	mg/(Pa·h·m)	UNI EN 12086
Dimension stability 48 h / 70 °C	DS(70,-)	≤ 1	%	UNI EN 1604
Fire reaction		E	Euroclass	UNI EN 13501-1
Long-term water absorption by total immersion	WL(T)	≤ 5	%	UNI EN 12087
Limit of operating temperature		70	°C	
Specific heat	C	1210	J/kg·°K	UNI EN 10456
Declaration according to UNI EN 13163	EPS-EN 13163-T2-L3-W3-S2-P5-BS 750-CS(10)500-DS(70,-)1-WL(T)5-MU(40-100)			



RDZ Klima pipe $\varnothing 12$

RDZ Klima pipe $\varnothing 12$ made of polybutylene with oxygen barrier, excellent flexibility for easy installation even in cold climates. It conforms to DIN 16968 and DIN 4726.

DIAMETER	ROLL	CODE
12 mm	300 m	1115120

Note:
for further technical data see page 173



Slim 9 Perimeter Belt

The edge insulation Slim 9 absorbs floor expansions and acts as thermo-acoustic insulation for the walls.

SIZE	CODE
5x90 mm	1071100



Open Elbow

Open Ø 12 elbow made of plastic material. It is used to support the pipes near the manifolds vertically and to protect them from any damage.

SIZE	CODE
Ø 12 mm	1130512



Isocoll 160

One-component polyurethane adhesive. Moisture hardener with low viscosity, flexible in use. This solventless glue reacts to the moisture in the air and turns to a fine and restrained foam.

SIZE	CODE
500 gr	1111112

Tips for material calculation

Mandatory product	Requirements
Super D Panel	Area to be covered +5%
RDZ Clima PB pipe Ø 12	Based on the average pitch. Total = area / pitch [m ² /m]
Slim 9 perimeter belt	1 metre per m ²
Open elbow Ø 12	2 for each circuit
Isocoll 160	1 bottle each 5 m ² approx

Optional product	Requirements
Inibitor XR20	2% of WHOLE water content
Biocide XR40	1% of WHOLE water content

Manifolds, electrothermal heads, accessories and optional products (from page 160).

Note: The requirements in the table are indicative. Please refer to the construction project for confirmation.

THERMAL OUTPUT OF THE SYSTEM

Thermal output in heating

Input data			
Screed coverings above the pipe	s_U	0.01	m
Heat conductivity of screed	λ_E	1.4	W(m·k)
Piper external diameter	d_a	0.012	m
Pipe wall thickness	s_R	0.0013	m
Pipe heat conductivity	λ_R	0.22	W(m·k)

T cm	K_H [m ² ·k]														
	$R_{\lambda,B}$ [m ² ·k/W]														
	0.01	0.02	0.03	0.04	0.05	0.06	0.07	0.08	0.09	0.10	0.11	0.12	0.13	0.14	0.15
8.1	7.125	6.596	6.158	5.779	5.448	5.153	4.890	4.653	4.438	4.242	4.063	3.898	3.747	3.606	3.476
12.2	5.696	5.233	4.889	4.605	4.360	4.145	3.952	3.778	3.620	3.476	3.343	3.220	3.106	3.000	2.901
16.3	4.893	4.453	4.154	3.916	3.715	3.540	3.384	3.244	3.116	2.998	2.891	2.791	2.698	2.612	2.531

$R_{\lambda,B}$: Heat conduction resistance of the floor covering
 T: Pipe spacing
 K_H : Equivalent thermal transmission coefficient

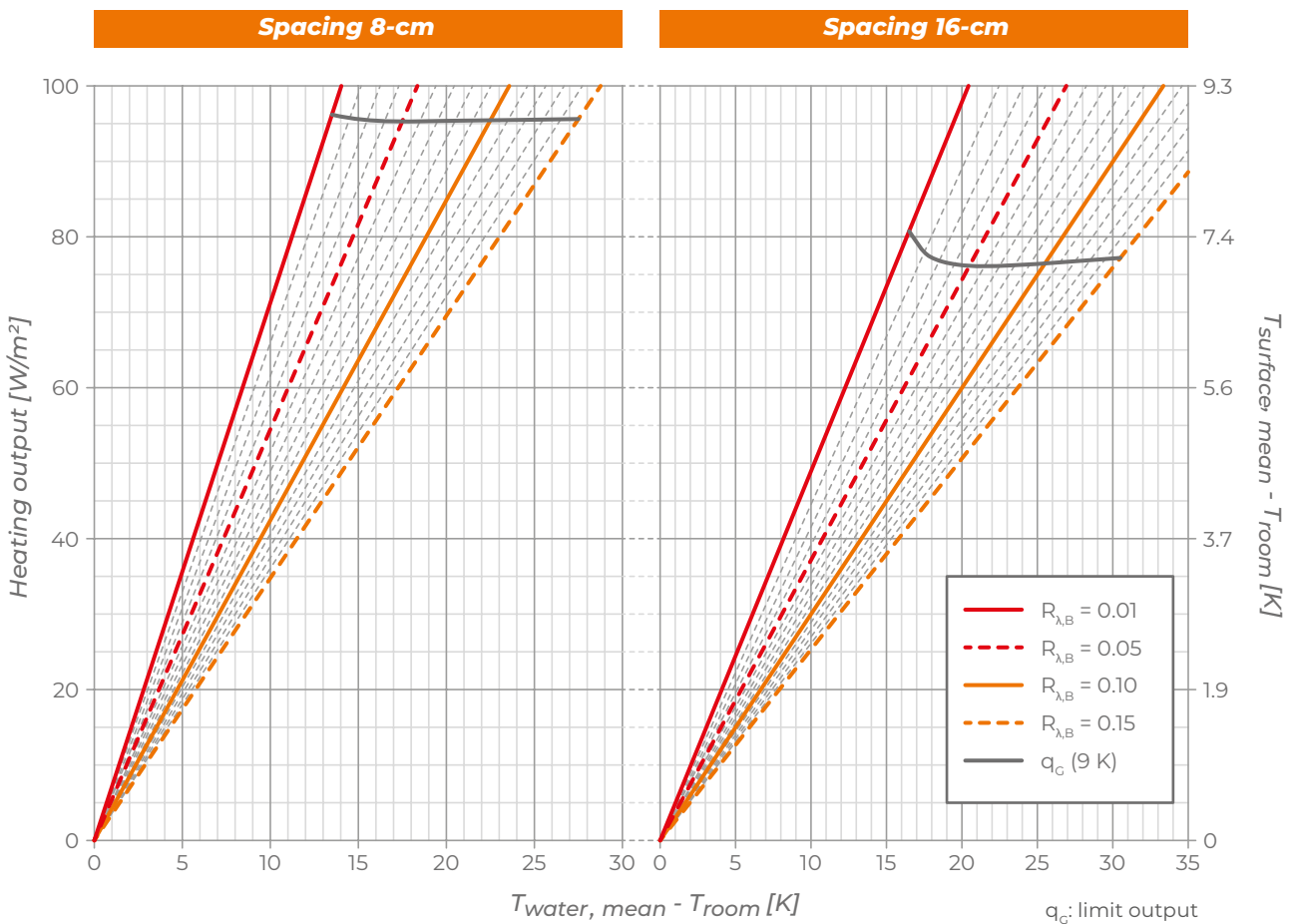

Thermal output in cooling

Input data			
Screed coverings above the pipe	s_U	0.01	m
Heat conductivity of screed	λ_E	1.4	W(m·k)
Piper external diameter	d_a	0.012	m
Pipe wall thickness	s_R	0.0013	m
Pipe heat conductivity	λ_R	0.22	W(m·k)

K_H [m ² ·k]															
$R_{\lambda,B}$ [m ² ·k/W]															
T cm	0.01	0.02	0.03	0.04	0.05	0.06	0.07	0.08	0.09	0.10	0.11	0.12	0.13	0.14	0.15
8.1	4.897	4.639	4.416	4.216	4.036	3.871	3.720	3.580	3.451	3.331	3.219	3.115	3.017	2.925	2.838
12.2	4.095	3.835	3.640	3.476	3.333	3.203	3.085	2.977	2.877	2.783	2.697	2.615	2.539	2.467	2.399
16.3	3.608	3.342	3.160	3.015	2.892	2.782	2.682	2.592	2.508	2.430	2.358	2.290	2.226	2.166	2.109

$R_{\lambda,B}$: Heat conduction resistance of the floor covering
 T: Pipe spacing
 K_H : Equivalent thermal transmission coefficient

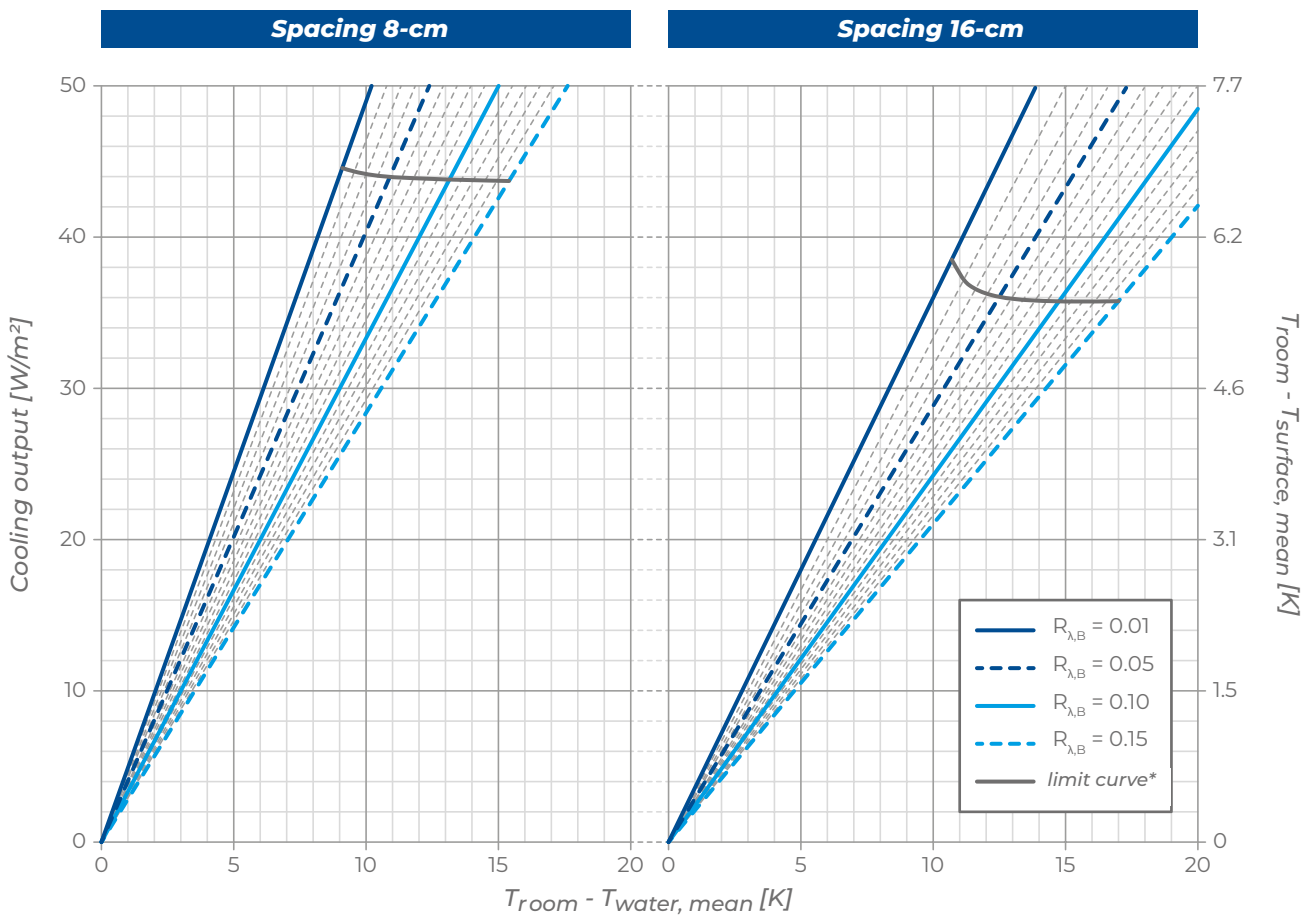

*valid only for room temperature = 26 °C



Zero Level AD is an underfloor heating and cooling system with low thermal inertia and very low thickness, characterised by \varnothing 12 mm PB pipe anchored to a thermoformed slab and embedded in the self-levelling concrete.

Thanks to its very small size, it is ideal for building renovation projects where the height available for the installation is limited.

The central element of the system is the thermoformed Zero Level AD panel, made of 1 mm thick regenerated plastic material. Used as a support for the pipe, it is equipped with a self-adhesive lower part for easy anchoring to the existing floor and with holes specially made to allow the self-levelling concrete to penetrate and cling to the substrate.

Without thermal insulation, the panel can be installed on top of any existing flooring or on an insulating support layer with a compressive strength greater than 400 kPa.

The system is completed by the RDZ Clima PB \varnothing 12 mm pipe with excellent flexibility to facilitate the installation of the circuits, the open support elbows, the manifold, the Slim 5 perimeteric belt and the Isocoll 160 adhesive for gluing the panel to the substrate.

FEATURES

- Very low thickness and low thermal inertia system
- PB \varnothing 12 mm pipe
- Panel without insulation
- Possibility of gluing the panel to the existing flooring
- Ideal for renovations and contemporary buildings



SECTION AND DIMENSIONS

- 1 Skirting board
- 2 Flooring
- 3 Special liquid concrete
- 4 PB pipe Ø 12x1.3 mm
- 5 Slim 5 insulation edge
- 6 Zero Level AD Panel
- 7 Primer
- 8 Substrate + levelling



System weight calculated with 5 mm level on the studs



Indicatives quotas

Panel thickness	18 mm
Quote with Tiles - Parquet flooring	3.3 - 4.3 cm
Quote with Marble - Blockboard flooring	4.3 - 6.3 cm

Suggested screeds

PRODUCER	SPECIAL LEVELLING SCREED	PRIMER
BASF	PCI Periplan extra	PCI Gisogrund 404
MAPEI	Ultraplan Maxi Novoplan Maxi	ECOPRIM T
KNAUF	NE 425	E-Grund
ROFIX	FN 645	AP 300
LATERLITE	PARIS SLIM	Latex CentroStorico

Note: please refer to the Zero Level AD installation manual and the data sheets of the suggested products.

Installation notes

- If the floor is in direct contact with the ground (i.e. without a sanitary void or insulating sheathing), provide adequate waterproofing and subsequent self-levelling concrete
- Check the suitability of the substrate: flatness, surface suitable for gluing
- Check the available height (minimum thickness of concrete: 5 mm above the studs)
- Proceed with the installation of the perimeter belt
- After carefully cleaning the substrate by removing dust and residues, remove the protection film from the panel adhesive layer and add Isocoll 160 for a stronger gluing
- Complete the system by laying the pipe as stated in the project
- Test the system and leave it under pressure until all subsequent installation and works are completed
- For the construction of the special concrete, follow the screed manufacturer's installation instructions

Note: Please refer to the installation manual for more information.

PRODUCTS THAT COMPOSE THE SYSTEM

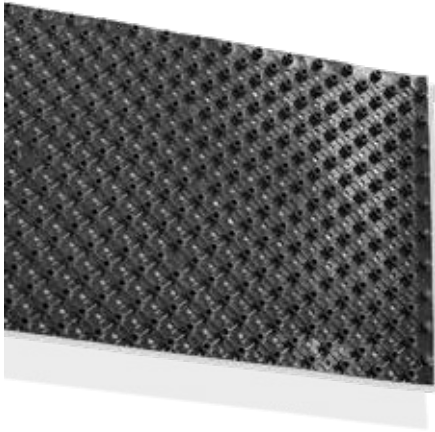

Zero Level AD Panel

Zero Level AD Panel is made of regenerated plastic material with high density and 1-mm thickness; it ensures a solid base in the building site and can be walked on. These panels have a tongue along the perimeter to connect them for accurate, secure join. Adhesive layer on the back, moulded surface with studs of 16 mm for 12-mm pipe laying, pipe spacing of 4 cm.

SIZE	THICKNESS	CODE
1215x810 mm	18 mm	1500000

Panel characteristics	Value	Unit	Standard
Size	1215x810x18	mm	
Thickness	1	mm	
Fluidity Index	4 ÷ 6	g/10min	ISO 1133
Vicat softening temperature	99	°C	ISO 306
Density at 23 °C	1.02 ÷ 1.05	g/cm ³	ASTM D792
Izod Impact Resistance at 23 °C	6 ÷ 8	KJ/m ²	ISO 180
Glue Specifications	Value	Unit	Standard
Viscosity according to Brookfield parameters at 160 °C	5.500	mPa/s	ICAT MI 13
Softening temperature	80	°C	ICAT MI 12
Open time at 160 °C	Limitless	s	ICAT MI 10



RDZ Clima PB Pipe Ø 12

RDZ Clima pipe Ø 12 made of polybutylene with anti-oxygen barrier, excellent flexibility for easy installation on low-temperature. It is produced in compliance with DIN 16968 and DIN 4726.

DIAMETER	ROLL	CODE
12 mm	300 m	1115120

Note:
for further technical data see page 173



Slim 5 Perimeter Belt

The edge insulation Slim 5 absorbs floor expansions and acts as thermo-acoustic insulation for the walls.

SIZE	CODE
5x50 mm	1200050



Open Elbow

Open Ø 12 elbow made of plastic material. It is used to support the pipes near the manifolds vertically and to protect them from any damage.

SIZE	CODE
Ø 12 mm	1130512



Isocoll 160

One-component polyurethane adhesive. Moisture hardener with low viscosity, flexible in use. This solventless glue reacts to the moisture in the air and turns to a fine and restrained foam.

SIZE	CODE
500 gr	1111112

Tips for material calculation

Mandatory product	Requirements
Zero Level AD panel	Area to be covered +5%
RDZ Clima PB pipe Ø 12	Based on the average laying pitch. Total = area / pitch [m ² /m]
Slim 5 perimeter belt	1 metre per m ²
Open elbow Ø 12	2 for each circuit
Isocoll 160	1 can each 16 m ² approx

Optional product	Requirements
Inibitor XR20	2% of WHOLE water content
Biocide XR40	1% of WHOLE water content

Manifolds, electrothermal heads, accessories and optional products (from page 160).

Note: The requirements in the table are indicative. Please refer to the construction project for confirmation.

THERMAL OUTPUT OF THE SYSTEM

Thermal output in heating

Input data			
Screed coverings above the pipe	s_U	0.005	m
Heat conductivity of screed	λ_E	1.4	W(m·k)
Piper external diameter	d_σ	0.012	m
Pipe wall thickness	s_R	0.0013	m
Pipe heat conductivity	λ_R	0.22	W(m·k)

K_H [m ² ·k]															
$R_{\lambda,B}$ [m ² ·k/W]															
T cm	0.01	0.02	0.03	0.04	0.05	0.06	0.07	0.08	0.09	0.10	0.11	0.12	0.13	0.14	0.15
8.1	7.469	6.819	6.312	5.891	5.529	5.211	4.930	4.679	4.454	4.249	4.062	3.892	3.735	3.591	3.457
12.2	6.260	5.645	5.217	4.875	4.587	4.339	4.118	3.921	3.743	3.583	3.436	3.300	3.175	3.061	2.954
16.3	5.228	4.656	4.292	4.012	3.781	3.583	3.410	3.254	3.114	2.987	2.871	2.764	2.665	2.574	2.488

$R_{\lambda,B}$: Heat conduction resistance of the floor covering
 T: Pipe spacing
 K_H : Equivalent thermal transmission coefficient

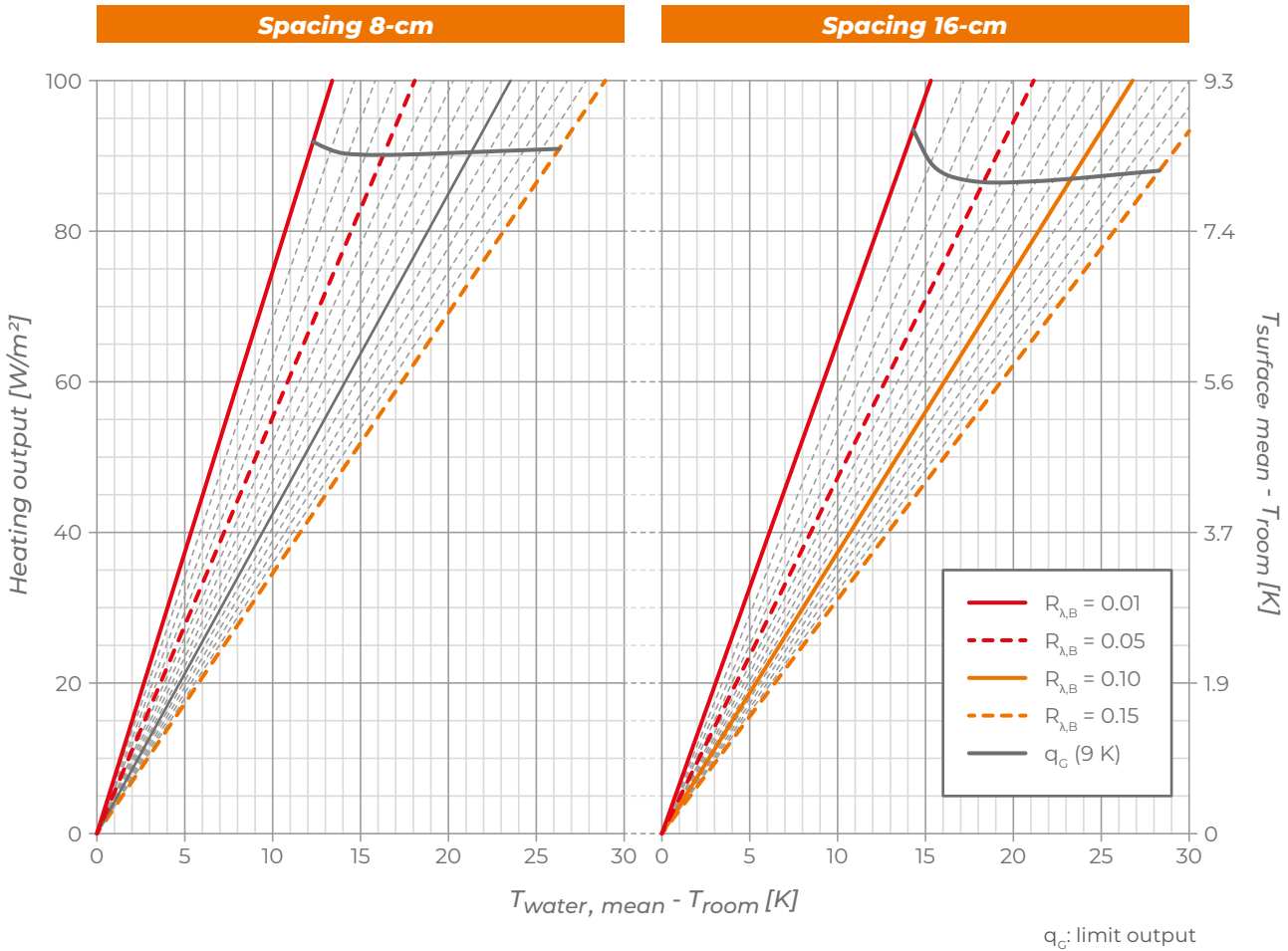

Thermal output in cooling

Input data			
Screed coverings above the pipe	s_U	0.005	m
Heat conductivity of screed	λ_E	1.4	W(m·k)
Piper external diameter	d_σ	0.012	m
Pipe wall thickness	s_R	0.0013	m
Pipe heat conductivity	λ_R	0.22	W(m·k)

K_H [m ² ·k]															
$R_{\lambda,B}$ [m ² ·k/W]															
T cm	0.01	0.02	0.03	0.04	0.05	0.06	0.07	0.08	0.09	0.10	0.11	0.12	0.13	0.14	0.15
8.1	4.986	4.673	4.422	4.205	4.013	3.839	3.682	3.538	3.405	3.282	3.168	3.061	2.962	2.869	2.782
12.2	4.297	3.970	3.736	3.548	3.386	3.242	3.113	2.995	2.887	2.787	2.694	2.607	2.526	2.450	2.380
16.3	3.673	3.340	3.128	2.964	2.828	2.708	2.602	2.506	2.418	2.337	2.262	2.192	2.126	2.065	2.007

$R_{\lambda,B}$: Heat conduction resistance of the floor covering
 T: Pipe spacing
 K_H : Equivalent thermal transmission coefficient

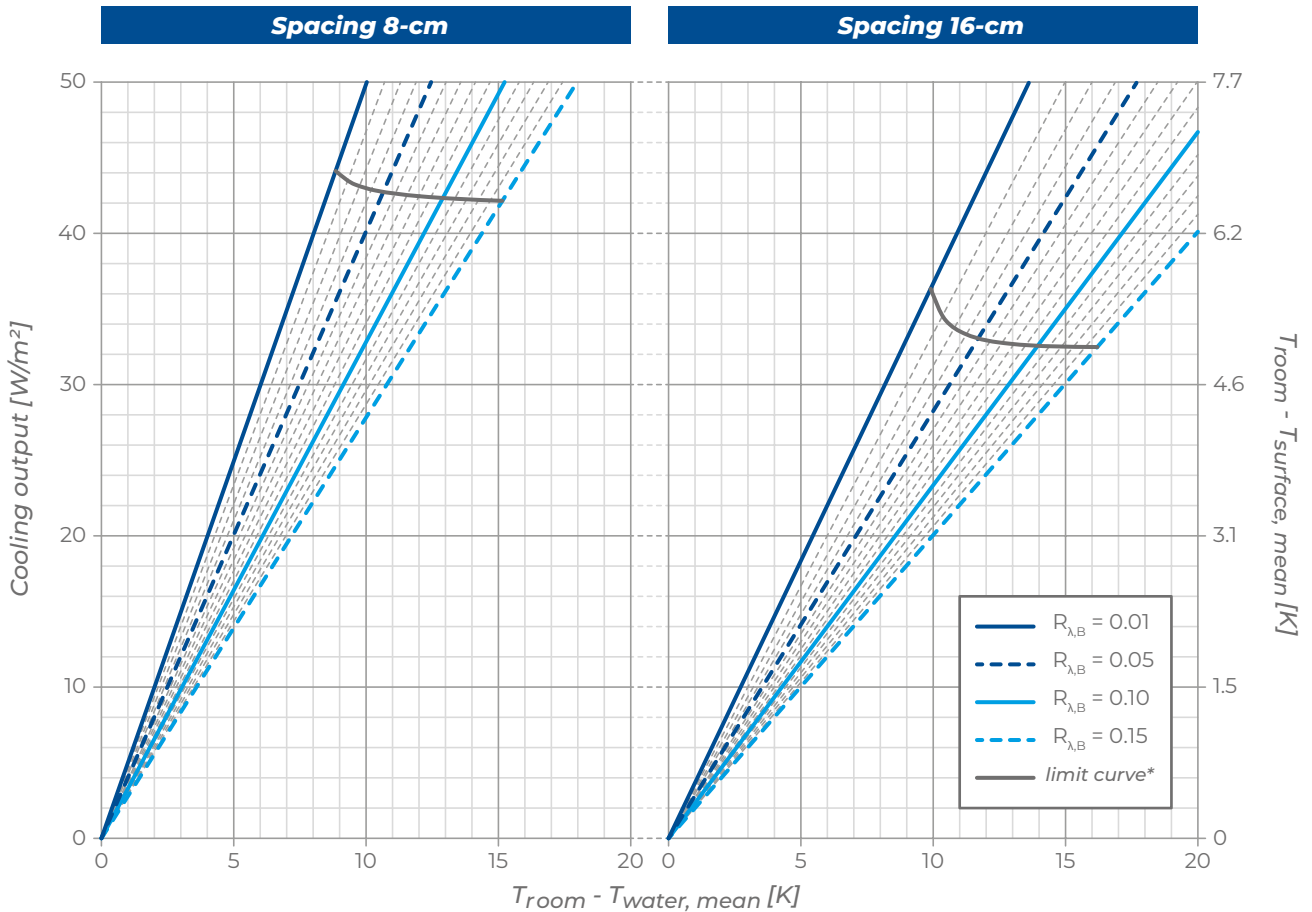

*valid only for room temperature = 26 °C

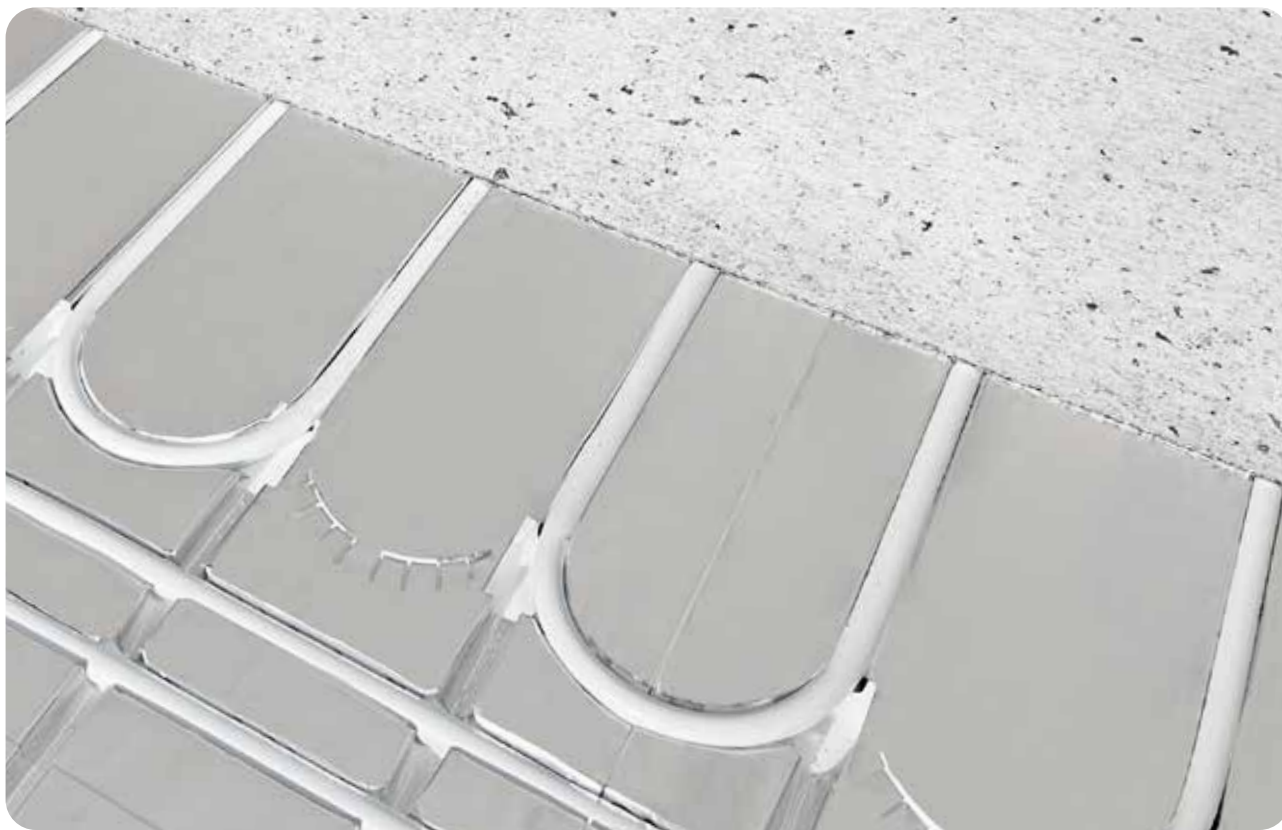

e-Dry Tech is an ultra-light dry underfloor heating and cooling system (weight less than 6 kg/m²) ideal in applications with limited available floor space or where the peculiarities of the building site make it difficult to use either traditional or lowered components.

The thickness of e-Dry Tech is only 29 mm, including both the panel and the load divider laid in place of the component. The absence of the component makes it possible to gain several centimetres in thickness, to have a floor immediately ready for flooring and makes the system operational without having to wait for the time needed for the component to dry.

The central element of the system is the e-Dry panel in sintered expanded polystyrene in compliance with UNI EN 13163, pre-coupled with an aluminium heat-diffusing layer and equipped with grooves to house the Ø 16 mm PE-RT/AL/PE-RT multilayer pipe.

The load divider is made up of laminated synthetic fibre sheets with very high mechanical resistance and impact noise attenuation properties. These, positioned over the radiant panel and joined together with RDZ paper adhesive tape, allow the creation of a single and uniform surface suitable for the application of the adhesive for the gluing of the tiles or to be covered with wood with a floating installation.

The system is completed with the pipe, the manifold, the Slim 5 perimeter belt, the open support elbows and the Isocoll 160 adhesive for gluing the panel to the substrate.

FEATURES

- Ultra-light dry system
- Only 2.9 cm thick (excluding flooring)
- Synthetic fibre load divider
- Multilayer Ø 16 mm pipe
- Ideal for mezzanines, renovations and contemporary buildings



SECTION AND DIMENSIONS

- 1 Skirting board
- 2 Flooring
- 3 Multilayer Pipe Ø 16
- 4 Slim 5 perimetral belt
- 5 Thermal diffuser
- 6 Paper adhesive tape
- 7 e-Dry panel
- 8 Isocoll 160
- 9 Substrate + levelling

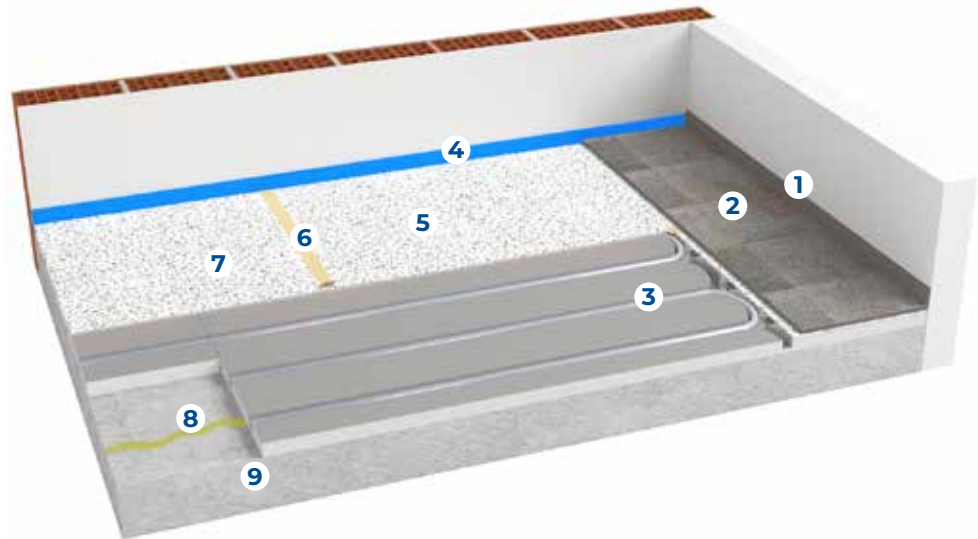

Weight of the system

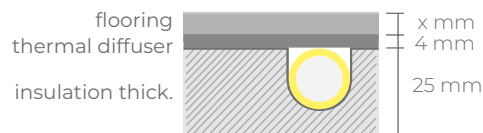

Indicatives quotas

Panel thickness	25 mm
Quote with Tiles - Parquet flooring	4.0 - 5.0 cm

For special coatings please refer to the installation manual

Installation notes

- If the floor is in direct contact with the ground (i.e. without a sanitary void or insulating sheathing), provide adequate waterproofing and subsequent levelling screed
- Check the suitability of the substrate: flatness, surface suitable for gluing
- Check the available dimensions
- Proceed with the installation of the perimeter belt
- After carefully cleaning the substrate by removing dust and material residues, glue the panels with the appropriate adhesive
- Lay the pipes as stated the project
- Test the system and leave it under pressure until all subsequent work is completed
- Coat the system with the synthetic fibre slabs joining them together using the appropriate adhesive paper tape

Notes for coverings

When laying square or rectangular tiles, the size of the longest side must not exceed 40 cm.

It is forbidden to lay gap-free coverings.

Bonding of wooden coverings is FORBIDDEN, as the thermal and hygrometric fluctuations in the covering can cause warping or lifting of the edges of the glued package.

For sizes other than those specified above, contact your trusted dealer for information on feasibility and the type of installation and glue to be used.

N.B.: for further information consult the installation manual.

■ PRODUCTS THAT COMPOSE THE SYSTEM



e-Dry Panel

Grooved insulation panel made of sintered expanded polystyrene complying with UNI EN 13163 (EPS 300). Prefabricated and applied aluminium foil on the top surface for heat emission. Special grooves to support the pipe coming from manifold. Pipe spacing: 15cm.

SIZE	THICKNESS	CODE
1200x750 mm	25 mm	1201006

Panel features	Level/Class	Value	Unit	Standard
Standard classification	Class	300		
Necessary Length	L(3)	1200 (± 3)	mm	UNI EN 13163:2015
Necessary Width	W(3)	750 (± 3)		
Total Thickness	T(2)	25 (± 2)		
Insulation base thickness		7		
Equivalent thickness		22.44		
Orthogonality	S(2)	± 2	mm/m	
Flatness	P(5)	5		
Thermal conductivity 10 °C		λ_D 0.032	W/(m·K)	
Calculated thermal resistance equivalent thickness		R_D 0.70	(m ² ·K)/W	
Resistance to compression with 10% deformation	CS(10)300	300	kPa	
Water vapour diffusion resistance factor		$\mu = 40 \div 100$		
Long-term water absorption by total immersion	WL(T) 6	≤ 6	%	
Water vapour permeability		$\delta = 0.006 \div 0.015$	mg/(Pa·h·m)	
Fire reaction of the product as placed on the market		Euroclass E		
Dimension stability 23 °C, 50% R.H.	DS(N)2	± 0.2	%	
Reaction to fire		Euroclass E		
Max. operating temperature		70	°C	
Unique identification code of the product-type according to UNI EN 13163				
Class 300 - EPS-UNI EN 13163:2015-T2-L3-W3-S2-P5-BS450-CS(10)300-WL(T)6-MU(40-100)				



Comfort Multilayer Pipe Ø 16

PE-RT Type II/Al/PE-RT Type II multilayer pipe Ø 16x2 mm according to UNI EN ISO 21003.

THICKNESS	ROLL	CODE
2 mm	300 m	1030016

Note:
for further technical data see page 175



Tech Load Distribution Layer

Load distribution layer made of laminated synthetic fibre with very high compression strength and acoustic properties for trample noise reduction. Reaction to fire Class E according to EN 13501.

SIZE	CODE
1000x600x4 mm	1202110

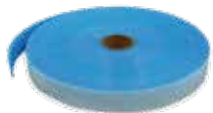

Slim 5 Perimeter Belt

The edge insulation Slim 5 absorbs floor expansions and acts as thermo-acoustic insulation for the walls.

SIZE	CODE
5x50 mm	1200050



Paper adhesive tape

Paper adhesive tape for fixing the synthetic fibre load divider.

SIZE	CODE
50 m	1202165



Open Elbow

Open elbow Ø 17 made of plastic material. It is used to support the pipes near the manifolds vertically and to protect them from any damage.

SIZE	CODE
Ø 17 mm	1130517



Isocoll 160

One-component polyurethane adhesive. Moisture hardener with low viscosity, flexible in use. This solventless glue reacts to the moisture in the air and turns to a fine and restrained foam.

SIZE	CODE
500 gr	1111112

Tips for material calculation

Mandatory product	Requirements
e-Dry panel	Area to be covered +10%
Comfort Multilayer Pipe Ø 16	Average laying pitch 15 cm. Total length = surface area/0.066 [m ² /m]
Slim 5 Perimeter Belt	1 metre per m ²
Tech Load Distribution Layer	Area to be covered +5%
Pape adhesive tape	1 metre per 2,7 m ²
Open elbow Ø 17	2 for each circuit
Isocoll 160	1 bottle each 4 m ²
Optional products	Requirements
Inibitor XR20	2% of WHOLE water content
Biocide XR40	1% of WHOLE water content

Manifolds, electrothermal heads, accessories and optional products (from page 160).

Note: The requirements in the table are indicative. Please refer to the construction project for confirmation.

THERMAL OUTPUT OF THE SYSTEM

Thermal output in heating

Input data			
Piper external diameter	d_o	0.016	m
Pipe wall thickness	s_R	0.002	m
Pipe heat conductivity	λ_R	0.45	W(m·k)

K_H [m ² ·k]																
$R_{\lambda,B}$ [m ² ·k/W]																
T cm	0.00	0.01	0.02	0.03	0.04	0.05	0.06	0.07	0.08	0.09	0.10	0.11	0.12	0.13	0.14	0.15
15	4,716	4,523	4,346	4,182	4,030	3,890	3,760	3,639	3,526	3,420	3,319	3,223	3,130	3,038	2,948	2,857

$R_{\lambda,B}$: Heat conduction resistance of the floor covering
 T : Pipe spacing
 K_H : Equivalent thermal transmission coefficient

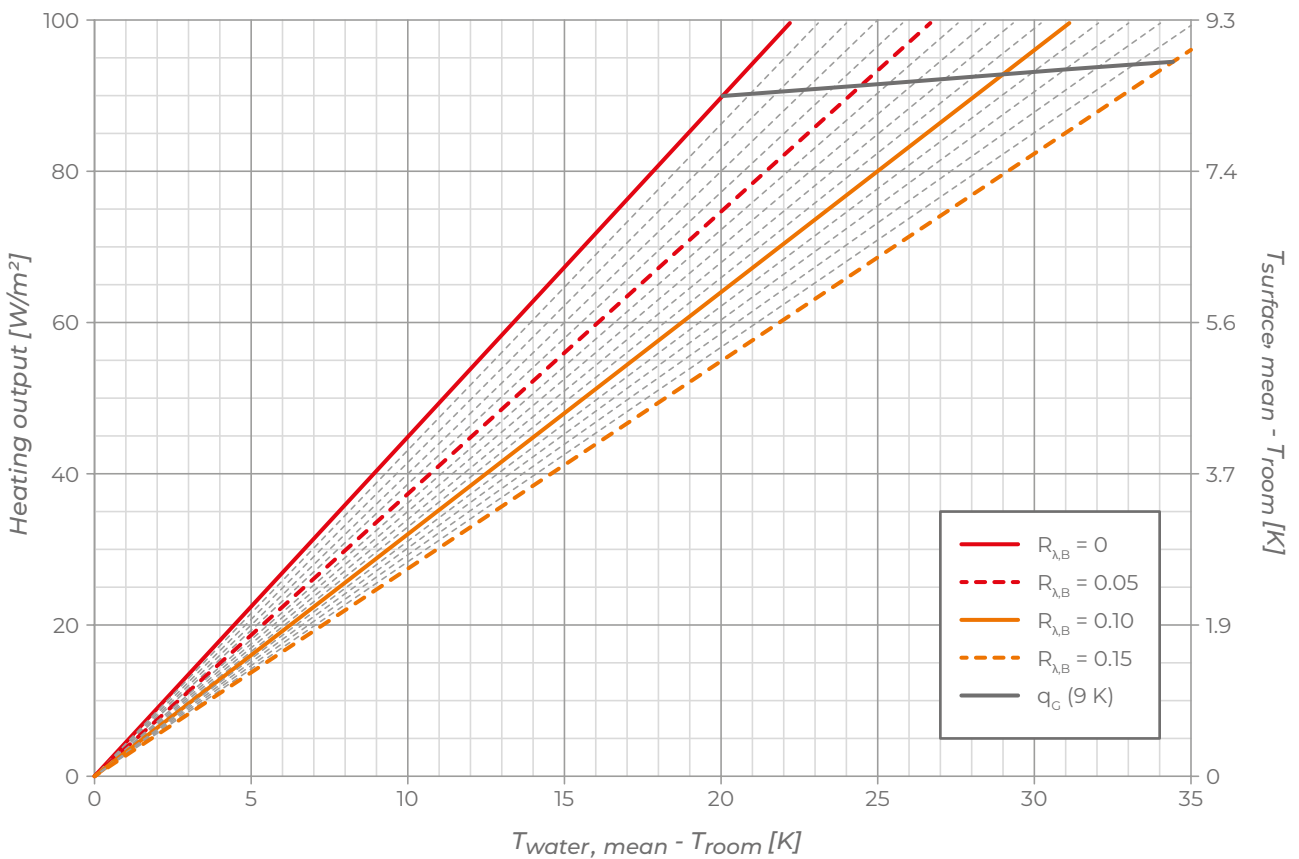

q_G: limit output

Thermal output in cooling

Input data			
Piper external diameter	d_o	0.016	m
Pipe wall thickness	s_R	0.002	m
Pipe heat conductivity	λ_R	0.45	W(m·k)

K_H [$m^2 \cdot k$]																
$R_{\lambda,B}$ [$m^2 \cdot k/W$]																
T cm	0.00	0.01	0.02	0.03	0.04	0.05	0.06	0.07	0.08	0.09	0.10	0.11	0.12	0.13	0.14	0.15
15	3,747	3,625	3,511	3,404	3,303	3,208	3,120	3,036	2,956	2,881	2,809	2,740	2,673	2,608	2,544	2,482

$R_{\lambda,B}$: Heat conduction resistance of the floor covering
 T: Pipe spacing
 K_H : Equivalent thermal transmission coefficient

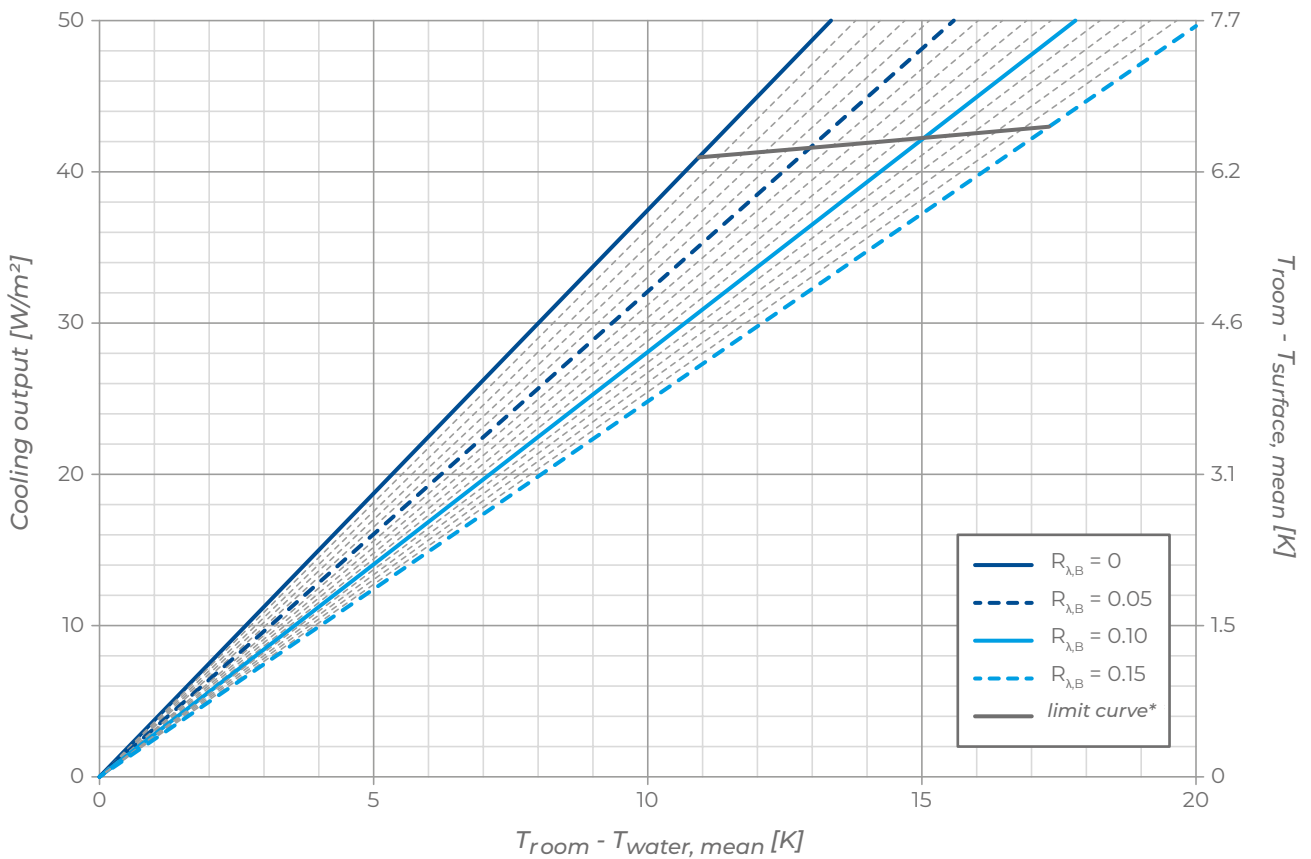

*valid only for room temperature = 26 °C



e-Dry EVO is a dry underfloor heating and cooling system ideal for renovations, lofts and all contemporary buildings that require very high energy efficiency.

In fact, e-Dry Evo is only 34 mm thick, including both the panel and the load distribution board installed instead of the concrete. The absence of the concrete makes it possible to gain several centimetres in thickness, to have a floor immediately ready for flooring and makes the system operational without waiting the time needed for the concrete to dry.

The central element of the system is the e-Dry panel in sintered expanded polystyrene in compliance with UNI EN 13163, pre-coupled with an aluminium heat-diffusing layer and equipped with grooves to house the Ø16 multilayer PE-RT/AL/PE-RT pipe.

The load distribution board, to be positioned above the radiant panel, consists of fireproof, asbestos-free calcium silicate sheets reinforced with cellulose fibres and inorganic additives. Thanks to the hinging, these allow the creation of a single surface without interruptions, suitable for the application of adhesive for the gluing of tiles or to be covered with wood floating installation.

The system is completed with the manifold, the Slim 5 perimeter belt, the open support elbows and Isocoll 160 for gluing the panel to the substrate.

FEATURES

- Very light dry system
- Only 3.4 cm thickness (excluding flooring)
- Calcium silicate load distributor
- Multilayer pipe Ø 16 mm
- Ideal for renovations and contemporary buildings



SECTION AND DIMENSIONS

- 1 Skirting board
- 2 Flooring
- 3 Multilayer Pipe Ø 16
- 4 Slim 5 Perimeter Belt
- 5 Calcium Silicate Board
- 6 E-DRY Panel
- 7 Isocoll 160
- 8 Substrate + levelling

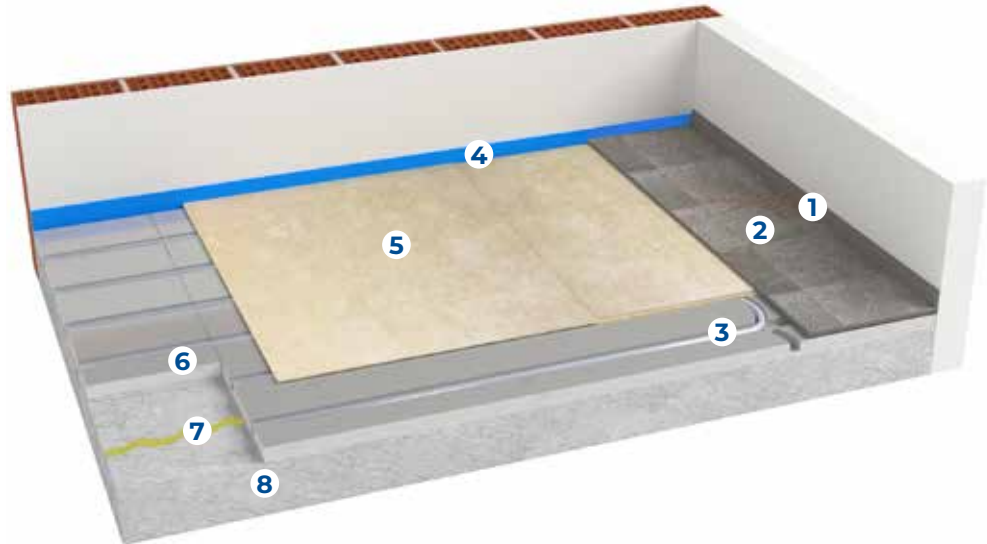

Weight of the system

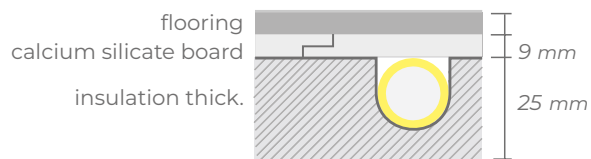

Indicative quotas

Panel thickness	25 mm
Quote with Tiles - Parquet flooring	4.5 - 5.5 cm

For special coatings please refer to the installation manual

Installation notes

- If the floor is in direct contact with the ground (i.e. without a sanitary void or insulating sheathing), provide adequate waterproofing and subsequent levelling screed
- Check the suitability of the substrate: flatness, surface suitable for gluing
- Check the available dimensions
- Proceed with the installation of the perimeter belt
- After carefully cleaning the substrate by removing dust and material residues, glue the panels with the appropriate adhesive
- Lay the pipes as stated the project
- Test the system and leave it under pressure until all subsequent works are completed
- Cover the system with calcium silicate slabs for even load distribution

Notes for coverings

When laying square or rectangular tiles, the size of the longest side must not exceed 40 cm.

It is forbidden to lay gap-free coverings.

Bonding of wooden coverings is FORBIDDEN, as the thermal and hygrometric fluctuations in the covering can cause warping or lifting of the edges of the glued package.

For sizes other than those specified above, contact your trusted dealer for information on feasibility and the type of installation and glue to be used.

N.B.: for further information consult the installation manual.

PRODUCTS THAT COMPOSE THE SYSTEM



e-Dry Panel

Grooved insulation panel made of sintered expanded polystyrene complying with UNI EN 13163 (EPS 300). Prefabricated and applied aluminium foil on the top surface for heat emission. Special grooves to support the pipe coming from manifold. Pipe spacing: 15 cm.

SIZE	THICKNESS	CODE
1200x750 mm	25 mm	1201006

Panel features	Level/Class	Value	Unit	Standard
Standard classification	Class	300		
Necessary Length	L(3)	1200 (± 3)	mm	UNI EN 13163:2015
Necessary Width	W(3)	750 (± 3)		
Total Thickness	T(2)	25 (± 2)		
Insulation base thickness		7		
Equivalent thickness		22.44		
Orthogonality	S(2)	± 2	mm/m	
Flatness	P(5)	5		
Thermal conductivity 10 °C		λ_D 0.032	W/(m·K)	
Calculated thermal resistance equivalent thickness		R_D 0.70	(m ² ·K)/W	
Resistance to compression with 10% deformation	CS(10)300	300	kPa	
Water vapour diffusion resistance factor		$\mu = 40 \div 100$		
Long-term water absorption by total immersion	WL(T) 6	≤ 6	%	
Water vapour permeability		$\delta = 0.006 \div 0.015$	mg/(Pa·h·m)	
Fire reaction of the product as placed on the market		Euroclass E		
Dimension stability 23 °C, 50% R.H.	DS(N)2	± 0.2	%	
Reaction to fire		Euroclass E		
Max. operating temperature		70	°C	
Unique identification code of the product-type according to UNI EN 13163				
Class 300 - EPS-UNI EN 13163:2015-T2-L3-W3-S2-P5-BS450-CS(10)300-WL(T)6-MU(40-100)				



Comfort Multilayer Pipe Ø 16

PE-RT Type II/Al/PE-RT Type II multilayer pipe Ø 16x2 mm according to UNI EN ISO 21003.

THICKNESS	ROLL	CODE
2 mm	300 m	1030016

Note:
for further technical data see page 175



Evo Load Distribution Layer

Tongue-and-groove board, made of hydrated calcium-silicate matrix reinforced with special cellulose fibres and inorganic additives. Reaction to fire Class A1 according to EN 13501.

SIZE	CODE
1200x1200x9 mm	1202255

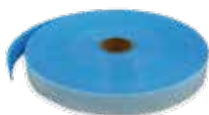

Slim 5 Perimeter Belt

The edge insulation Slim 5 absorbs floor expansions and acts as thermo-acoustic insulation for the walls.

SIZE	CODE
5x50 mm	1200050



Paper adhesive tape

Paper adhesive tape for fixing the synthetic fibre load divider.

SIZE	CODE
50 m	1202165



Open Elbow

Open elbow Ø 17 made of plastic material. It is used to support the pipes near the manifolds vertically and to protect them from any damage.

SIZE	CODE
Ø 17 mm	1130517



Isocoll 160

One-component polyurethane adhesive. Moisture hardener with low viscosity, flexible in use. This solventless glue reacts to the moisture in the air and turns to a fine and restrained foam.

SIZE	CODE
500 gr	1111112

Tips for material calculation

Mandatory product	Requirements
e-Dry panel	Area to be covered +10%
Comfort Multilayer Pipe Ø 16	Average laying pitch 15 cm. Total length = surface area/0.066 [m ² /m]
Slim 5 Perimeter Belt	1 metre per m ²
Calcium Silicate Board	Area to be covered +5%
Open Elbow Ø 17	2 for each circuit
Isocoll 160	1 bottle each 4 m ²

Optional product	Requirements
Inhibitor XR20	2% of WHOLE water content
Biocide XR40	1% of WHOLE water content

Manifolds, electrothermal heads, accessories and optional products (from page 160).

Note: The requirements in the table are indicative. Please refer to the construction project for confirmation..

THERMAL OUTPUT OF THE SYSTEM

Thermal output in heating

Input data			
Piper external diameter	d_a	0.016	m
Pipe wall thickness	s_R	0.002	m
Pipe heat conductivity	λ_R	0.45	W(m·k)

K_H [m ² ·k]																
$R_{\lambda,B}$ [m ² ·k/W]																
T cm	0.00	0.01	0.02	0.03	0.04	0.05	0.06	0.07	0.08	0.09	0.10	0.11	0.12	0.13	0.14	0.15
15	4,505	4,329	4,166	4,016	3,877	3,748	3,628	3,516	3,410	3,309	3,213	3,120	3,029	2,939	2,848	2,755

$R_{\lambda,B}$: Heat conduction resistance of the floor covering
 T : Pipe spacing
 K_H : Equivalent thermal transmission coefficient

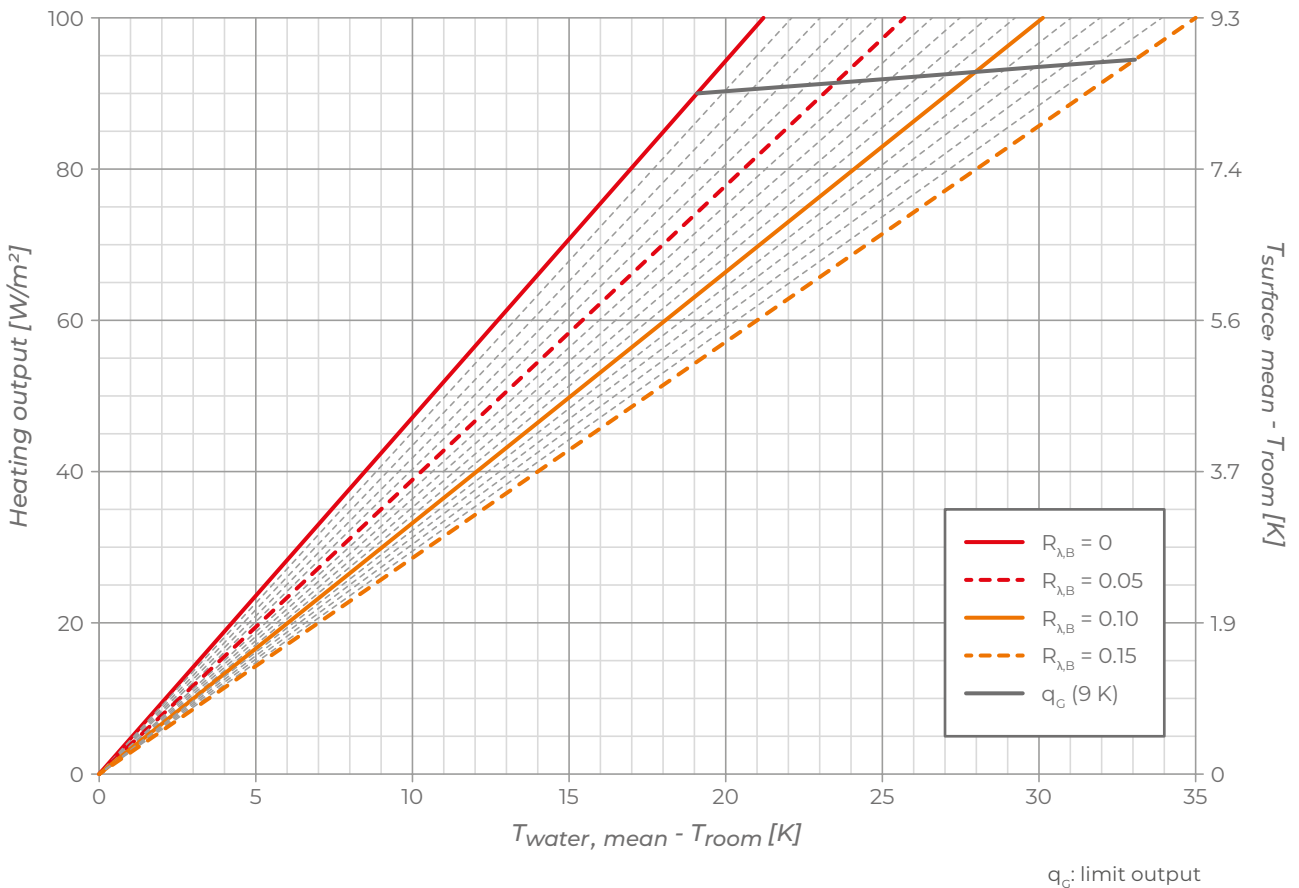

q_c : limit output

Thermal output in cooling

Input data			
Piper external diameter	d_o	0.016	m
Pipe wall thickness	s_R	0.002	m
Pipe heat conductivity	λ_R	0.45	W(m·k)

K_H [$m^2 \cdot k$]																
$R_{\lambda,B}$ [$m^2 \cdot k/W$]																
T cm	0.00	0.01	0.02	0.03	0.04	0.05	0.06	0.07	0.08	0.09	0.10	0.11	0.12	0.13	0.14	0.15
15	3,613	3,500	3,393	3,293	3,199	3,111	3,027	2,948	2,873	2,802	2,733	2,666	2,602	2,538	2,475	2,413

$R_{\lambda,B}$: Heat conduction resistance of the floor covering
 T : Pipe spacing
 K_H : Equivalent thermal transmission coefficient

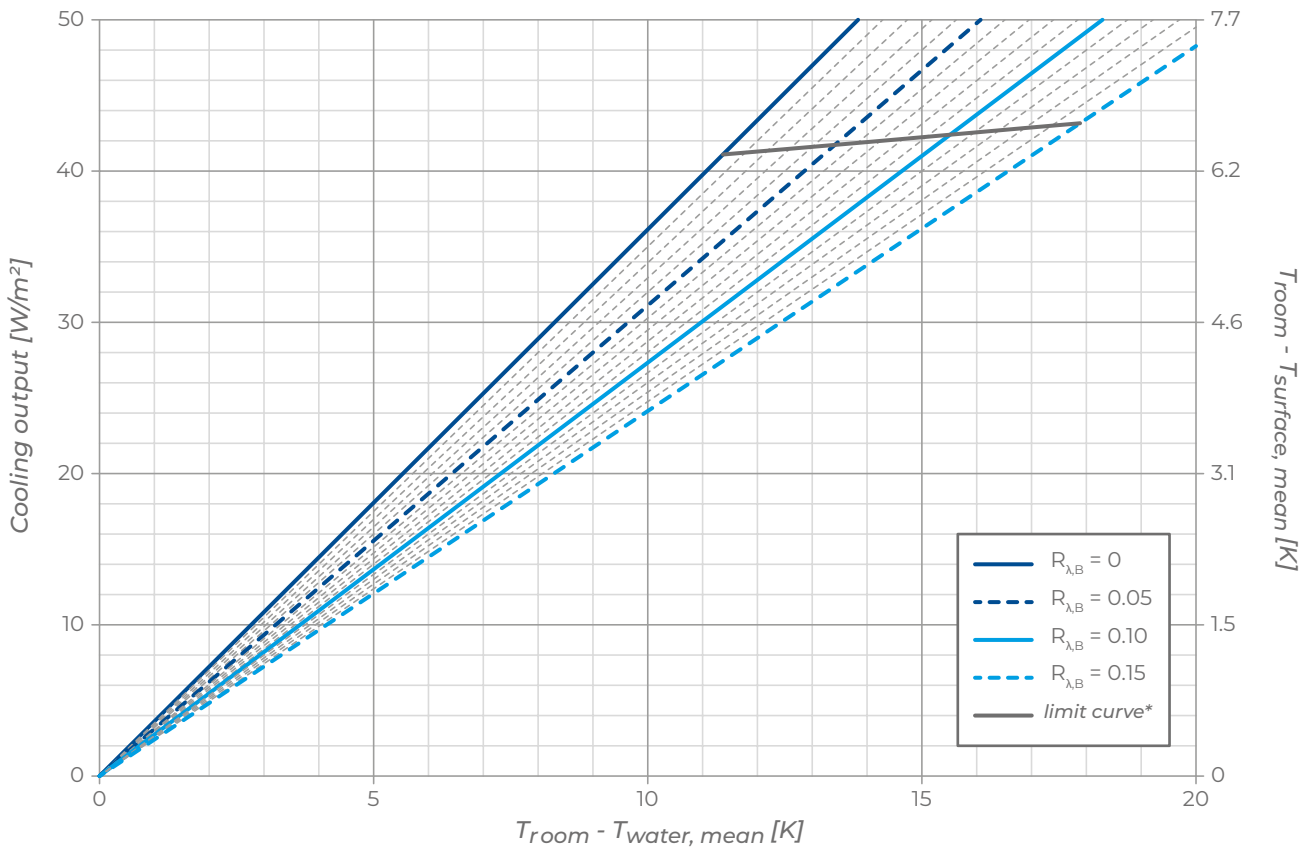

*valid only for room temperature = 26 °C



**Traditional underfloor
radiant system**





Comfort and consumptions reduced in every season

Traditional underfloor heating systems are the ideal choice for residential and commercial buildings, and for all rooms where it is necessary to maintain a constant internal temperature throughout the day.

Made with pipes anchored to an insulating base and embedded in the traditional screed, these systems can be used for both heating and cooling and are able to guarantee beautiful, spacious and clutter-free rooms, where the uniform distribution of temperature and the sensation of physical well-being are combined with considerable energy savings.

In order to meet various design and use requirements, traditional underfloor radiant systems are available in many versions with insulating panels of different composition and thickness: smooth or studded, with graphitic additives to improve thermal insulation performance, designed for greater mechanical resistance or specific for acoustics.

ADVANTAGES OF TRADITIONAL UNDERFLOOR SYSTEMS:



**WIDE RANGE
OF SOLUTIONS**



**UNIQUE SYSTEM FOR
HEATING AND COOLING**



**APPLICATION
VERSATILITY**



**EASY AND FAST
INSTALLATION**



**COMFORT AND
ENERGY SAVING**

PARAMETERS FOR THE CHOICE OF INSULATION

The following is explicitly about the parameters mentioned in the UNI EN 1264-4 standard, which suggests the minimum thermal resistance values to be respected depending on the thermal conditions underneath the room being heated with the floor.

Thermal Resistance $R_{\lambda,ins}$ (m^2K/W)	Heated room below	Unheated or non-continuously heated below or directly on the ground*	external air temperature below		
	0.75	1.25	Design outside Temperature $T_d \geq 0^\circ C$	Design outside Temperature $0 > T_d \geq -5^\circ C$	Design outside Temperature $-5^\circ C > T_d \geq -15^\circ C$
	"A"	"B"		"C"	"D"

(*) With a level of groundwater ≤ 5 m the value should be increased







Studded panels

Panel type	Panel total thickness S [mm]	Thickness of the panel base S [mm]	Thermal resistance according to FprEN 1264(2) (with base thik.) $R_{\lambda,INS}$ [m^2K/W]
COVER HP 24	52	24	0.75
COVER HP 39	67	39	1.25
COVER HP 47	75	47	1.50
COVER HP 62	90	62	2.00
COVER 20	48	20	0.55
COVER 30	58	30	0.85
ACOUSTIC PLUS 20	48	20	0.50
ACOUSTIC PLUS 30	58	30	0.80
NEW PLUS	33	12.5	0.35
T50 20	46	20	0.60
T50 30	56	30	0.85
T50 40	66	40	1.10
T50 46	72	46	1.30
TF HP 10	33	10	0.30
TF HP 20	43	20	0.65
TF HP 33	56	33	1.10
TF HP 40	62	40	1.30
TF 10	33	10	0.25
TF 20	43	20	0.60
TF 30	53	30	0.85
TF 40	63	40	1.15
PRL 20	20	20	0.55
PRL 27	27	27	0.75
PRL 44	44	44	1.25
PRL HP 20	20	20	0.65
PRL HP 23	23	23	0.75
PRL HP 30	30	30	1.00
PRL HP 38	38	38	1.25

Smooth panels

Panel type	Panel total thickness S [mm]	Thickness of the panel base S [mm]	Thermal resistance according to EN 1264(1) (with equivalent thik.) $R_{\lambda,INS}$ [m^2K/W]
ACURAPID B 20	20	20	0.50
ACURAPID B 30	30	30	0.75
SMOOTH COVER HP 24	24	24	0.75
SMOOTH COVER HP 39	39	39	1.25
SMOOTH COVER HP 47	47	47	1.50
SMOOTH COVER HP 62	62	62	2.00

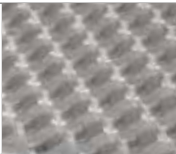
SYSTEM CHOICE BY THICKNESS

System		Thickness [mm]	Pipe [mm]	Base [mm]	Stud/Clips [mm]	Concrete [mm]	Total [mm]			
Cover HP page 98		24	PE-X Ø 17	24	28	40	92			
		39	PE-X Ø 17	39	28	40	107			
		47	PE-X Ø 17	47	28	40	115			
		62	PE-X Ø 17	62	28	40	130			
Cover page 104		20	PE-X Ø 17	20	28	40	88			
		30	PE-X Ø 17	30	28	40	98			
Acoustic Plus page 110		20	PE-X Ø 17	20	28	40	88			
		30	PE-X Ø 17	30	28	40	98			
Acurapid page 116		20	PE-RT Ø 17	20	20	40	80			
		30	PE-RT Ø 17	30	20	40	90			
Smooth Cover HP page 122			PE-X Ø 17	PE-Xa Ø 20						
		24	Ø 17	Ø 20	24	20	23	40	84	87
		39	Ø 17	Ø 20	39	20	23	40	99	102
		47	Ø 17	Ø 20	47	20	23	40	107	110
New Plus page 128		12.5	PE-X Ø 17	12.5	20.5	40	73			
T50 page 134		20	PE-X Ø 17	20	26	40	86			
		30	PE-X Ø 17	30	26	40	96			
		40	PE-X Ø 17	40	26	40	106			
		46	PE-X Ø 17	46	26	40	112			
TF HP page 140		10	PE-RT Ø 17	10	22	40	72			
		20	PE-RT Ø 17	20	22	40	82			
		33	PE-RT Ø 17	33	22	40	95			
		40	PE-RT Ø 17	40	22	40	102			
TF page 146		10	PE-RT Ø 17	10	22	40	72			
		20	PE-RT Ø 17	20	22	40	82			
		30	PE-RT Ø 17	30	22	40	92			
		40	PE-RT Ø 17	40	22	40	102			
PRL HP page 152		20	PE-RT Ø 17	20	20	40	80			
		23	PE-RT Ø 17	23	20	40	83			
		30	PE-RT Ø 17	30	20	40	90			
		38	PE-RT Ø 17	38	20	40	98			
PRL page 152		20	PE-RT Ø 17	20	20	40	80			
		27	PE-RT Ø 17	27	20	40	87			
		44	PE-RT Ø 17	44	20	40	104			



Cover HP is a traditional underfloor heating and cooling system with radiant panels, characterised by pipe anchored to the insulated base and embedded in the screed.

Invisible and efficient, it can be used in both residential and commercial applications and it is ideal for applications where it is necessary to maintain a constant room temperature throughout the day.

The central element of the system is the Cover HP studed panel made of sintered polystyrene with graphite and compliant with UNI EN 13163.

Available in a wide range of thicknesses (24, 39, 47 and 62 mm), it satisfies many different requirements and, thanks to the presence of graphite, offers excellent thermal insulation performance even with reduced overall dimensions.

The system is completed by RDZ Tech PE-X pipe \varnothing 17 mm made of high-density polyethylene, cross-linked and provided with anti-oxygen barrier according to DIN 4726, the hooked clips, the open support elbows, the manifold, the Cover HP smooth panel, the Plus perimeter belt and the 4S thermo-fluidifying additive.

FEATURES

- Sintered polystyrene panel with graphite
- RDZ Tech pipe \varnothing 17 mm
- Provides excellent thermal insulation
- Available in thicknesses 24-39-47-62 mm
- Suitable for residential and commercial applications
- Easy and quick installation



SECTION AND DIMENSIONS

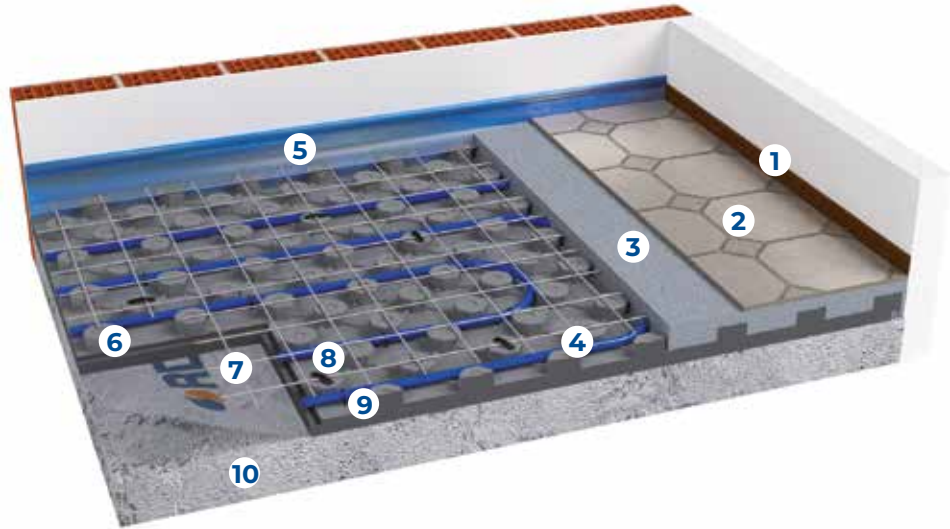

- 1 Skirting board
- 2 Flooring
- 3 Concrete
- 4 RDZ Tech pipe Ø 17-13
- 5 Plus perimeter belt
- 6 Cover HP panel
- 7 Anti-shrinkage mesh
- 8 Clip 75
- 9 Hooked clip
- 10 Substrate + levelling

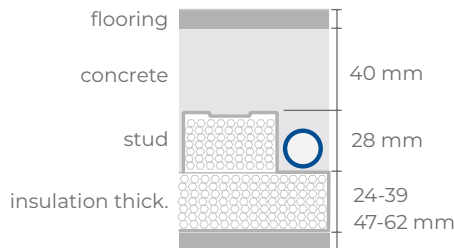

Indicative quotas

Panel thickness	24 mm	39 mm	47 mm	62 mm
Quote with Tiles - Parquet flooring	10.2 - 11.2 cm	11.7 - 12.7 cm	12.5 - 13.5 cm	14 - 15 cm
Quote with Marble - Blockboard flooring	11.2 - 13.2 cm	12.7 - 14.7 cm	13.5 - 15.5 cm	15 - 17 cm

Installation notes

- If the floor is in direct contact with the ground (i.e. without a sanitary void or insulating sheathing), provide a polyethylene sheet to act as a moisture barrier.
- Check that the site is clear and clean
- Check the dimensions available, taking into consideration the thickness of the insulation, screed and flooring chosen.
- Lay the perimeter belt and the insulation panels
- Lay the pipes as stated the project
- Usually, it's not necessary to bend the pipe with a bending radius of less than 12.5 cm, i.e. with a laying pitch of less than 25 cm
- Test the system and leave it under pressure until all subsequent works are completed
- If necessary, install the anti-shrinkage mesh

Note: Please refer to the installation manual for more information.

PRODUCTS THAT COMPOSE THE SYSTEM



Cover HP Panel

Cover HP panel with studs made of waterproof sintered polystyrene with graphite, produced in conformity with UNI EN 13163, with closed-cell structure, which has high compression strength. It is combined with a special plastic film in order to protect it from humidity in compliance with EN 1264. They have a moulded surface with reliefs of 28 mm so that the pipes can be fitted into the tabs of the panel at spacing of 8.3 cm or multiples.

SIZE	THICKNESS	CODE
1161x663 mm	24 mm	1056324
1161x663 mm	39 mm	1056339
1161x663 mm	47 mm	1056347
1161x663 mm	62 mm	1056362

Panel features	Symbol	24	39	47	62	Unit	Standard
Necessary Length	L1	1161				mm	UNI EN 822
Necessary Width	W1	663				mm	UNI EN 822
Total Thickness	T4	52	67	75	90	mm	UNI EN 823
Insulation base thickness		24	39	47	62	mm	
Equivalent thickness		32.97	47.97	55.97	70.97	mm	UNI EN 1264/3
Compressive stress at 10% deformation	CS(10)	120				kPa	UNI EN 826
Thermal conductivity at 10 °C	λ_D	0.031				W/(m·K)	UNI EN 13163
Thermal resistance equivalent thickness	R_D	0.75	1.25	1.50	2.00	(m ² ·K)/W	UNI EN 1264:2021
Transmittance	U	1.33	0.80	0.67	0.50	W/(m ² ·K)	
Water vapour diffusion resistance factor	μ (MU)	30÷70					UNI EN 12086
Dimension stability 48h/70°C	DS(70,-)	≤ 1				%	UNI EN 1604
Reaction to fire class		F				Euroclass	UNI EN 13501-1
Water absorption by partial immersion	Wlp	0.5				kg/m ²	UNI EN 12087
Long-term water absorption by total immersion	WL(T)	≤ 3				%	UNI EN 12087
Max operating temperature		70				°C	
Specific heat	C	1210				J/kg·°k	UNI EN 10456
HIPS Foil thickness		150				µm	
Declaration according to UNI EN 13163							
Unique identification code of the product-type: EPS-EN 13163-T2-L3-W3-S2-P5-BS 170-CS(10)120-DS(70,-)1-WL(T)3-MU(30-70)							

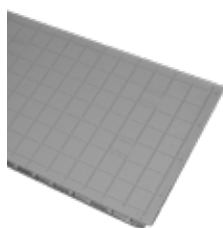

Cover HP Smooth Panel

Smooth Cover HP panel is made of waterproof expanded polystyrene with graphite, produced in conformity with UNI EN 13163, with closed-cell structure, which has high compression strength. It is combined with a special plastic film in order to protect it from humidity in compliance with EN 1264.

SIZE	THICKNESS	CODE
1161x663 mm	24 mm	1056426
1161x663 mm	39 mm	1056436
1161x663 mm	47 mm	1056446
1161x663 mm	62 mm	1056456



RDZ Tech PE-Xa Pipe Ø 17 Interior Layer

RDZ Tech PE-Xa pipe Ø 17-13 made of high-density cross-linked polyethylene with the oxygen barrier between the PE-X layer and an outer layer made of PE, which ensures further protection during installation in the building site. The layers are combined thanks to a special glue.

TYPE	ROLL	CODE
PE-Xa	240 m	1013840
PE-Xa	600 m	1013850

Note: for further technical data see page 178



Plus Perimeter Belt

Plus perimeter belt is the edge insulation, which absorbs floor expansions and acts as thermo-acoustic insulation for the walls.

SIZE	CODE
5x150 mm	1071250



Hooked clip

Hooked clips made of plastic material to ensure secure positioning of the pipe on the insulating panels.

PACKAGE	CODE
100 pieces	1017000



Open Elbow

Open elbow Ø 17 made of plastic material. It is used to support the pipes near the manifolds vertically and to protect them from any damage.

SIZE	CODE
Ø 17 mm	1130517



Thermofluidifying Additive 4S

Superfluxing, multidosage, water reducing admixture for concrete to increase its workability and to improve its mechanical properties and thermal conductivity. It is a product which conforms to EN 934-2; T3.1 - 3.2.

SIZE	CODE
10 liters	1091911
20 liters	1091921

Tips for material calculation

Mandatory product	Requirements
Cover HP panel	Area to be covered +3%
Smooth Cover HP panel	1 pack each manifold
RDZ Tech pipe Ø 17 mm	Average pitch. Total = surface area / pitch [m ² /m]
Plus perimeter belt	1 metre per m ²
Open elbow Ø 17	2 for each circuit
Hooked clip	5 for each circuit
Thermofluidifying Additive 4S	Approx. 0.2 litres per m ²

Optional product	Requirements
Fibreglass Mesh	Area to be covered +10%
RDZ Fiber (polypropylene fibres)	1 kg per 16 m ²
Clip 75	To be used only if anti-shrinkage mesh is used. 5 clips/m ²
Humidity Barrier Sheet	Surface to be covered +20%
Inibitor XR20	2% of ENTIRE water content
Biocide XR40	1% of ENTIRE water content

Manifolds, electrothermal heads, accessories and optional products (from page 160).

Note: The requirements in the table are indicative. Please refer to the construction project for confirmation..

THERMAL OUTPUT OF THE SYSTEM

Thermal output in heating

Input data			
Screed coverings above the pipe	s_U	0.045	m
Heat conductivity of screed	λ_E	1.2	W(m·k)
Piper external diameter	d_a	0.017	m
Pipe wall thickness	s_R	0.002	m
Pipe heat conductivity	λ_R	0.35	W(m·k)

K_H [m ² ·k]																
$R_{\lambda,B}$ [m ² ·k/W]																
T cm	0.00	0.01	0.02	0.03	0.04	0.05	0.06	0.07	0.08	0.09	0.10	0.11	0.12	0.13	0.14	0.15
8.3	6.556	6.111	5.723	5.383	5.081	4.812	4.571	4.352	4.154	3.974	3.809	3.656	3.516	3.386	3.266	3.154
16.6	5.144	4.834	4.565	4.328	4.119	3.934	3.760	3.603	3.461	3.331	3.213	3.099	2.994	2.896	2.806	2.722
24.9	4.067	3.850	3.663	3.500	3.356	3.230	3.105	2.994	2.893	2.802	2.719	2.634	2.555	2.482	2.415	2.353

$R_{\lambda,B}$: Heat conduction resistance of the floor covering
 T: Pipe spacing
 K_H : Equivalent thermal transmission coefficient

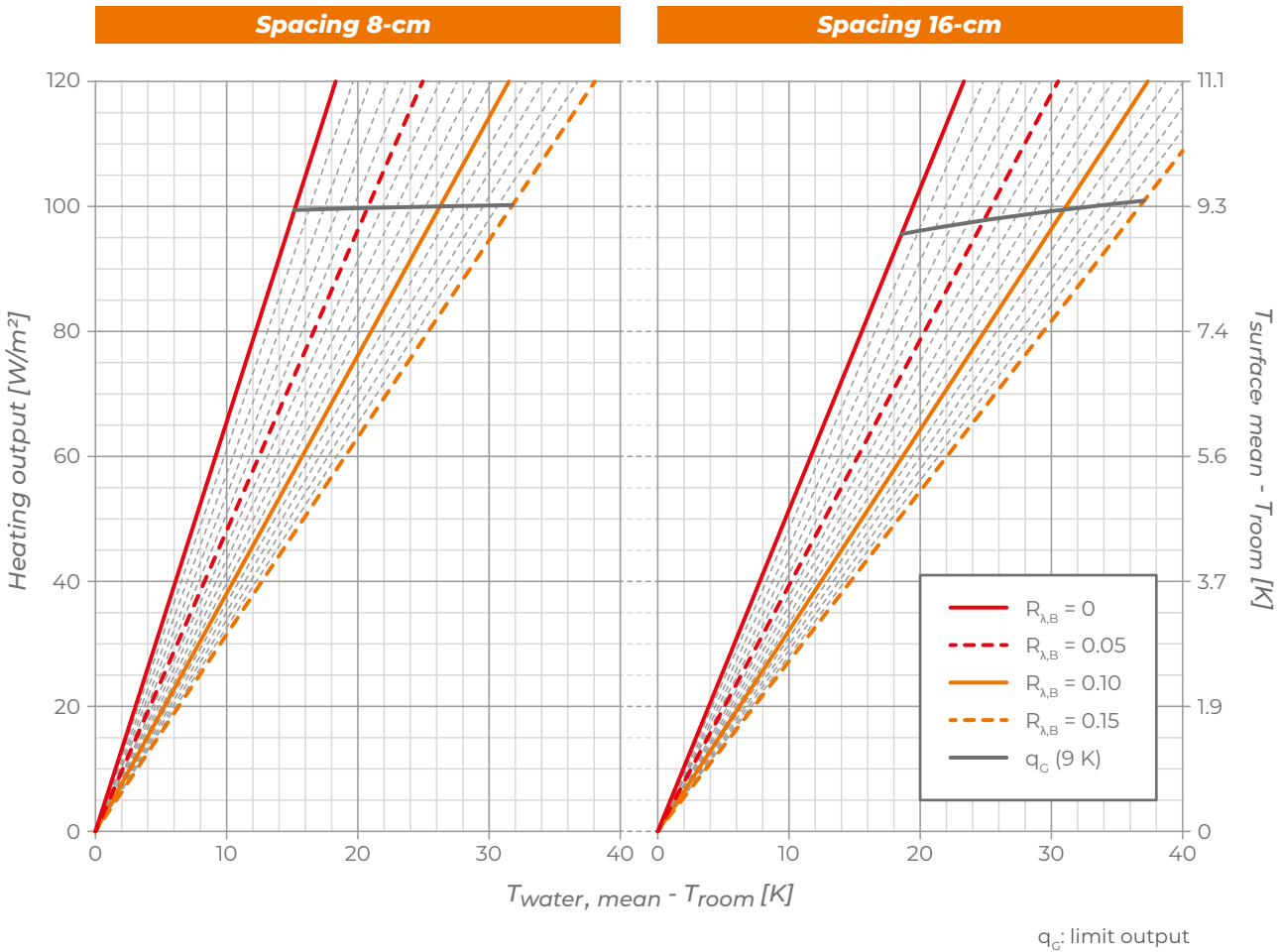

q_G : limit output

Thermal output in cooling

Input data			
Screed coverings above the pipe	s_U	0.045	m
Heat conductivity of screed	λ_E	1.2	W(m·k)
Piper external diameter	d_a	0.017	m
Pipe wall thickness	s_R	0.002	m
Pipe heat conductivity	λ_R	0.35	W(m·k)

K_H [m ² ·k]																
$R_{\lambda,B}$ [m ² ·k/W]																
T cm	0.00	0.01	0.02	0.03	0.04	0.05	0.06	0.07	0.08	0.09	0.10	0.11	0.12	0.13	0.14	0.15
8.3	4.551	4.334	4.138	3.958	3.793	3.642	3.502	3.372	3.252	3.140	3.035	2.938	2.846	2.760	2.679	2.602
16.6	3.774	3.616	3.471	3.338	3.214	3.099	2.992	2.893	2.799	2.712	2.630	2.552	2.479	2.410	2.345	2.283
24.9	3.135	3.022	2.916	2.818	2.727	2.641	2.560	2.484	2.413	2.345	2.281	2.221	2.163	2.109	2.057	2.008

$R_{\lambda,B}$: Heat conduction resistance of the floor covering
 T: Pipe spacing
 K_H : Equivalent thermal transmission coefficient

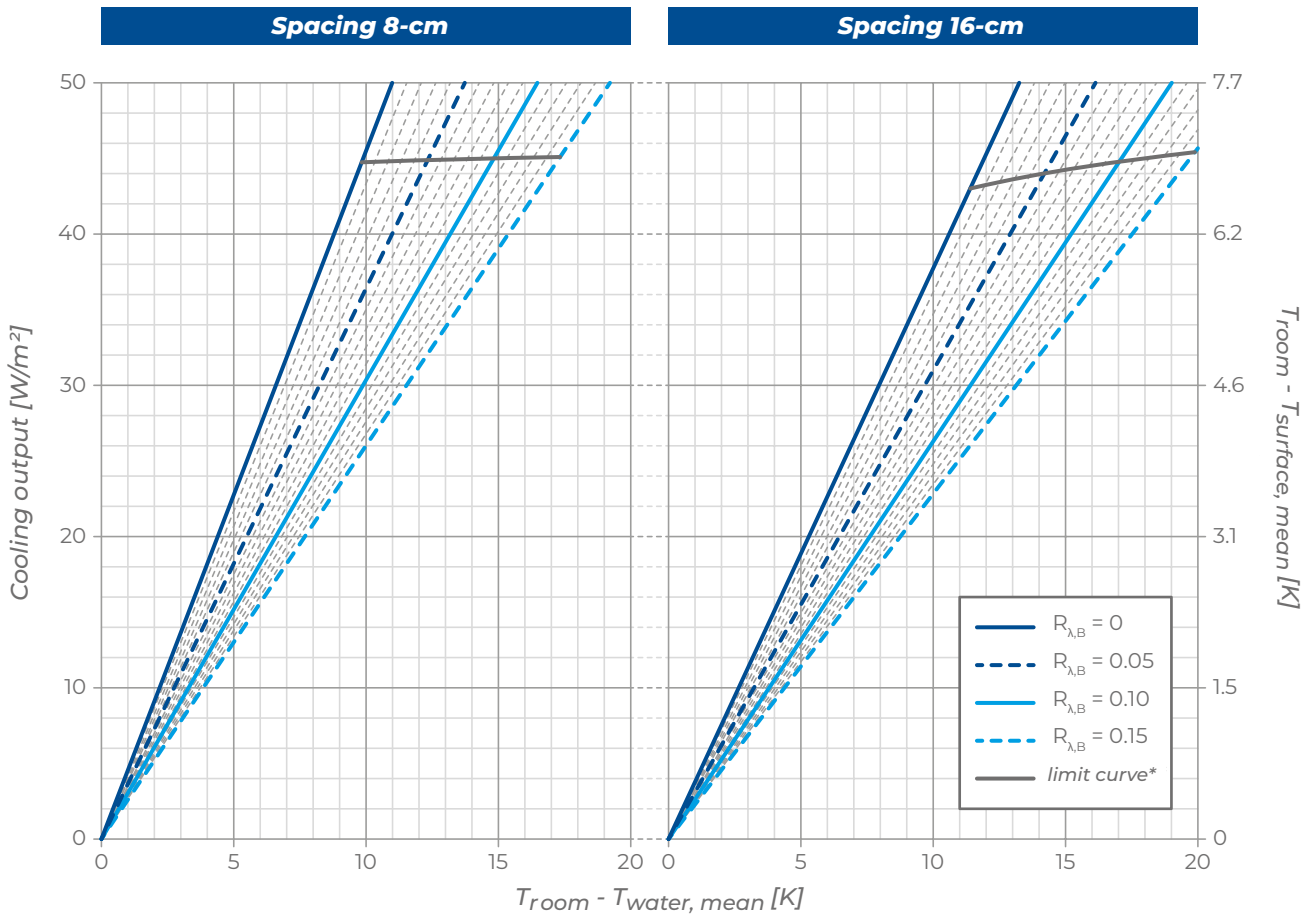

*valid only for room temperature = 26 °C



Cover is a traditional underfloor radiant heating and cooling system, characterised by pipe anchored to an insulated base and embedded in the screed.

Ideal for applications where it is necessary to maintain a constant room temperature throughout the day, it can be used in numerous applications ranging from the residential to the commercial applications.

The central element of the system is the studded Cover panel made of sintered expanded polystyrene produced in compliance with UNI EN 13163, coated on the surface with plastic film and available in thicknesses of 20 and 30 mm.

The system is completed by RDZ Tech PE-X pipe \varnothing 17 mm made of high-density cross-linked polyethylene and provided with anti-oxygen barrier according to DIN 4726, the hooked clips, the open support elbows, the manifold, the smooth Cover panel, the Plus perimeter belt and the 4S thermo-fluidifying additive.

FEATURES

- Excellent thermal insulation
- RDZ Tech \varnothing 17 mm
- High mechanical resistance of the panel
- Suitable for residential and commercial applications
- Easy and quick installation



SECTION AND DIMENSIONS

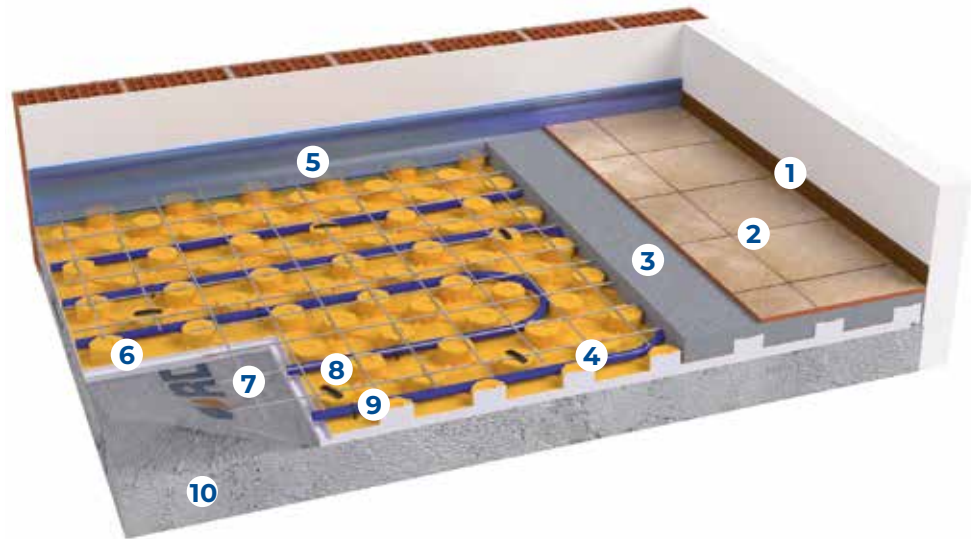

- 1 Skirting board
- 2 Flooring
- 3 Concrete
- 4 RDZ Tech pipe Ø 17-13
- 5 Plus perimeter belt
- 6 Cover panel
- 7 Anti-shrinkage mesh
- 8 Clip 75
- 9 Hooked clip
- 10 Substrate + levelling

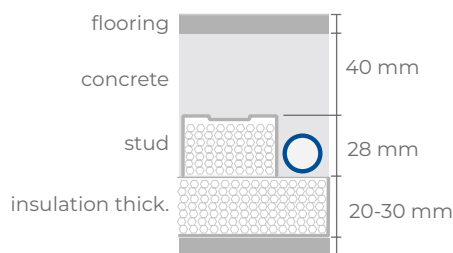

Indicative quotas

Panel thickness	20 mm	30 mm
Quote with Tiles - Parquet flooring	10 - 11 cm	11 - 12 cm
Quote with Marble - Blockboard flooring	11 - 13 cm	12 - 14 cm

Installation notes

- If the floor is in direct contact with the ground (i.e. without a sanitary void or insulating sheathing), provide a polyethylene sheet to act as a moisture barrier.
- Check that the site is clear and clean
- Check the dimensions available, taking into consideration the thickness of the insulation, screed and flooring chosen.
- Lay the perimeter belt and the insulation panels
- Lay the pipes as stated the project
- Usually, it's not necessary to bend the pipe with a bending radius of less than 12.5 cm, i.e. with a laying pitch of less than 25 cm
- Test the system and leave it under pressure until all subsequent works are completed
- If necessary, install the anti-shrinkage mesh

Note: Please refer to the installation manual for more information.

PRODUCTS THAT COMPOSE THE SYSTEM

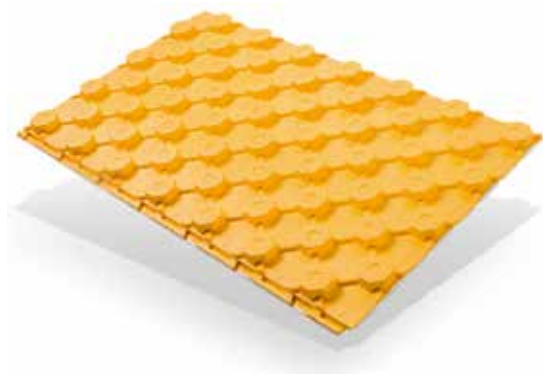

Cover Panel

Cover panel with studs made of waterproof moulded expanded polystyrene, produced in conformity with UNI EN 13163, with closed-cell structure, which has high compression strength. They have a moulded surface with studs of 28 mm so that the pipes can be fitted into the tabs of the panel at spacing of 8.3 cm or multiples.

SIZE	THICKNESS	CODE
1161x663 mm	20 mm	1056020
1161x663 mm	30 mm	1056030

Panel features	Symbol	20	30	Unit	Standard
Necessary Length	L1	1161		mm	UNI EN 822
Necessary Width	W1	663		mm	UNI EN 822
Total Thickness	T4	48	58	mm	UNI EN 823
Insulation base thickness		20	30	mm	
Equivalent thickness		28.96	38.97	mm	UNI EN 1264/3
Compressive stress at 10% deformation	CS(10)	120		kPa	UNI EN 826
Thermal conductivity at 10 °C	λ_D	0.035		W/(m·K)	UNI EN 13163
Thermal resistance base thickness	R_D	0.55	0.85	(m ² ·K)/W	UNI EN 1264:2021
Water vapour diffusion resistance factor	μ (MU)	30 ÷70			UNI EN 12086
Dimension stability 48h / 70°C	DS(70,-)	≤ 0.5		%	UNI EN 1604
Reaction to fire class		F		Euroclass	UNI EN 13501-1
Long term water absorption by partial immersion	Wlp	0.5		kg/m ²	UNI EN 12087
Long-term water absorption by total immersion	WL(T)	≤ 3		%	UNI EN 12087
Limit of operating temperature		70		°C	
Specific heat	C	1450		J/kg·°K	UNI EN 10456
HIPS Foil thickness		150		µm	
Declaration according to UNI EN 13163					
Unique identification code of the product-type: EPS-EN 13163-T2-L3-W3-S2-P5-BS 170-CS(10)120-DS(70,-)1-WL(T)3-MU(30-70)					

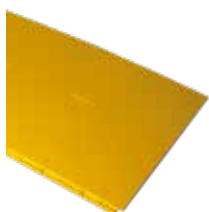

Cover Smooth Panel

Cover smooth panel made of waterproof moulded expanded polystyrene, produced in conformity with UNI EN 13163, with closed-cell structure. This panel is combined with a special plastic film in order to protect it from humidity in compliance with EN 1264.

SIZE	THICKNESS	CODE
1161x663 mm	20 mm	1056120
1161x663 mm	30 mm	1056130



RDZ Tech PE-Xa Pipe Ø 17 Interior Layer

RDZ Tech PE-Xa pipe Ø 17-13 made of high-density cross-linked polyethylene with the oxygen barrier between the PE-X layer and an outer layer made of PE, which ensures further protection during installation in the building site. The layers are combined thanks to a special glue.

TYPE	ROLL	CODE
PE-Xa	240 m	1013840
PE-Xa	600 m	1013850

Note: for further technical data see page 178



Plus perimeter belt

Plus perimeter belt is the edge insulation, which absorbs floor expansions and acts as thermo-acoustic insulation for the walls.

SIZE	CODE
5x150 mm	1071250



Hooked clip

Hooked clips made of plastic material to ensure secure positioning of the pipe on the insulating panels.

PACKAGE	CODE
100 pieces	1017000



Open Elbow

Open elbow Ø 17 made of plastic material. It is used to support the pipes near the manifolds vertically and to protect them from any damage.

SIZE	CODE
Ø 17 mm	1130517



Thermofluidifying Additive 4S

Superfluxing, multidosage, water reducing admixture for concrete to increase its workability and to improve its mechanical properties and thermal conductivity. It is a product which conforms to EN 934-2; T3.1 - 3.2.

SIZE	CODE
10 liters	1091911
20 liters	1091921

Tips for material calculation

Needed products	Requirements
Cover panel	Area to be covered +3%
Smooth COVER panel	1 pack per manifold
RDZ Tech pipe Ø 17 mm	Depending on the average pitch. Total = surface area / pitch [m ² /m]
Plus perimeter belt	1 metre per m ²
Open elbow Ø 17	2 for each circuit
Hooked clip	5 for each circuit
Thermofluidifying Additive 4S	Approx. 0.2 litres per m ²

Optional products	Requirements
Fibreglass Mesh	Area to be covered +10%
RDZ Fiber (polypropylene fibres)	1 kg per 16 m ²
Clip 75	To be used only if anti-shrinkage mesh is used. 5 clips/m ²
Humidity Barrier Sheet	Area to be covered +20%
Inibitor XR20	2% of ENTIRE water content
Biocide XR40	1% of ENTIRE water content

Manifolds, heads, accessories and optional products (from page 160).

Note: The requirements in the table are indicative. Please refer to the construction project for confirmation..

THERMAL OUTPUT OF THE SYSTEM

Thermal output in heating

Input data			
Screed coverings above the pipe	s_U	0.045	m
Heat conductivity of screed	λ_E	1.2	W(m·k)
Piper external diameter	d_o	0.017	m
Pipe wall thickness	s_R	0.002	m
Pipe heat conductivity	λ_R	0.35	W(m·k)

K_H [$m^2 \cdot k$]																
$R_{\lambda,B}$ [$m^2 \cdot k/W$]																
T cm	0.00	0.01	0.02	0.03	0.04	0.05	0.06	0.07	0.08	0.09	0.10	0.11	0.12	0.13	0.14	0.15
8.3	6.555	6.110	5.723	5.382	5.081	4.812	4.570	4.352	4.154	3.973	3.808	3.656	3.516	3.386	3.265	3.153
16.6	5.144	4.833	4.564	4.328	4.119	3.933	3.759	3.602	3.460	3.331	3.213	3.099	2.993	2.896	2.806	2.722
24.9	4.066	3.850	3.662	3.499	3.356	3.230	3.105	2.993	2.893	2.802	2.719	2.633	2.555	2.482	2.415	2.353

$R_{\lambda,B}$: Heat conduction resistance of the floor covering
 T: Pipe spacing
 K_H : Equivalent thermal transmission coefficient

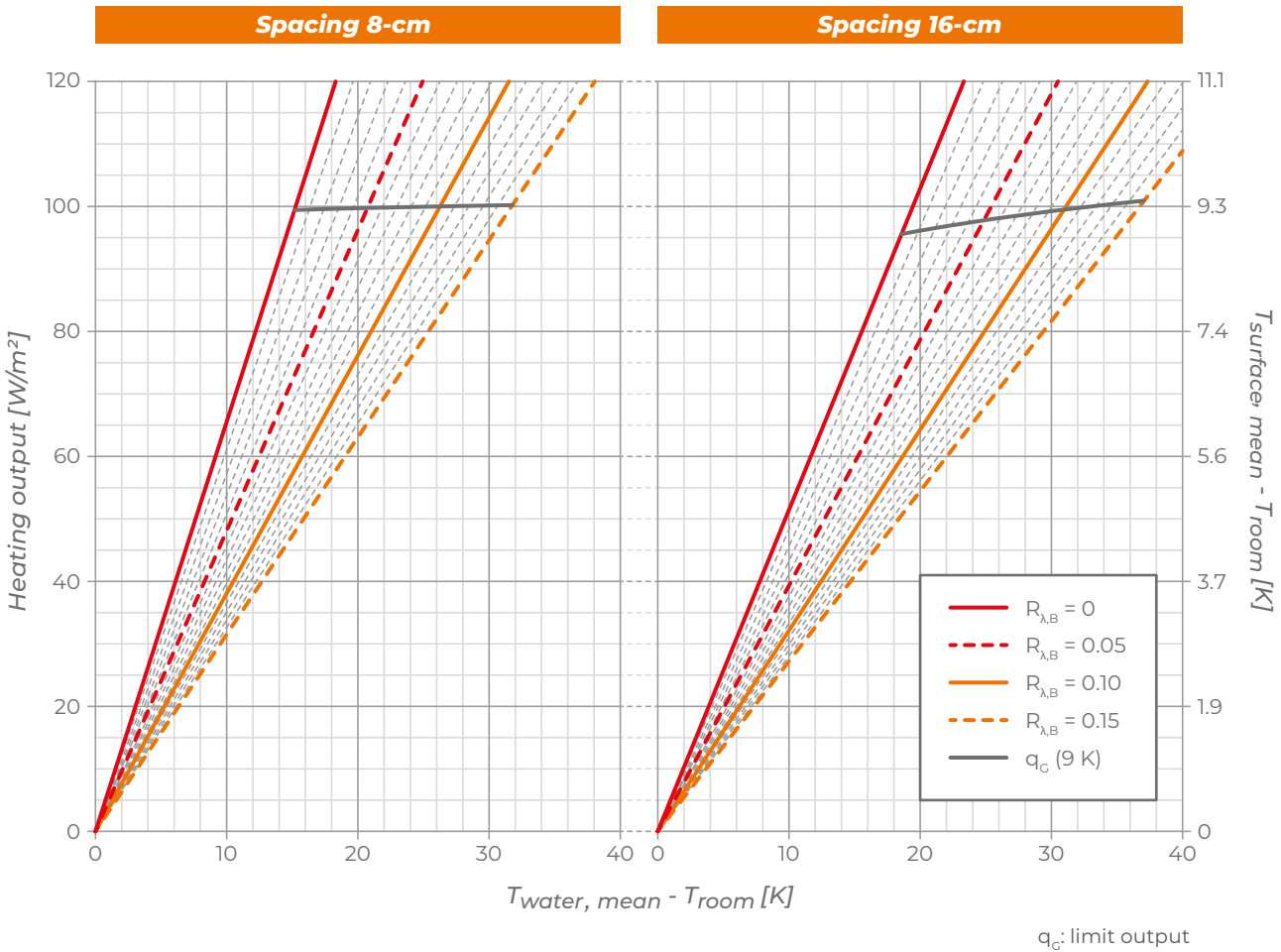

q_G : limit output

Thermal output in cooling

Input data			
Screed coverings above the pipe	s_U	0.045	m
Heat conductivity of screed	λ_E	1.2	W(m·k)
Piper external diameter	d_o	0.017	m
Pipe wall thickness	s_R	0.002	m
Pipe heat conductivity	λ_R	0.35	W(m·k)

K_H [m ² ·k]																
$R_{\lambda,B}$ [m ² ·k/W]																
T cm	0.00	0.01	0.02	0.03	0.04	0.05	0.06	0.07	0.08	0.09	0.10	0.11	0.12	0.13	0.14	0.15
8.3	4.550	4.334	4.137	3.958	3.793	3.641	3.502	3.372	3.252	3.140	3.035	2.937	2.846	2.760	2.678	2.602
16.6	3.773	3.616	3.471	3.338	3.214	3.099	2.992	2.892	2.799	2.712	2.629	2.552	2.479	2.410	2.345	2.283
24.9	3.134	3.021	2.916	2.818	2.726	2.640	2.560	2.484	2.412	2.345	2.281	2.221	2.163	2.109	2.057	2.008

$R_{\lambda,B}$: Heat conduction resistance of the floor covering
 T: Pipe spacing
 K_H : Equivalent thermal transmission coefficient

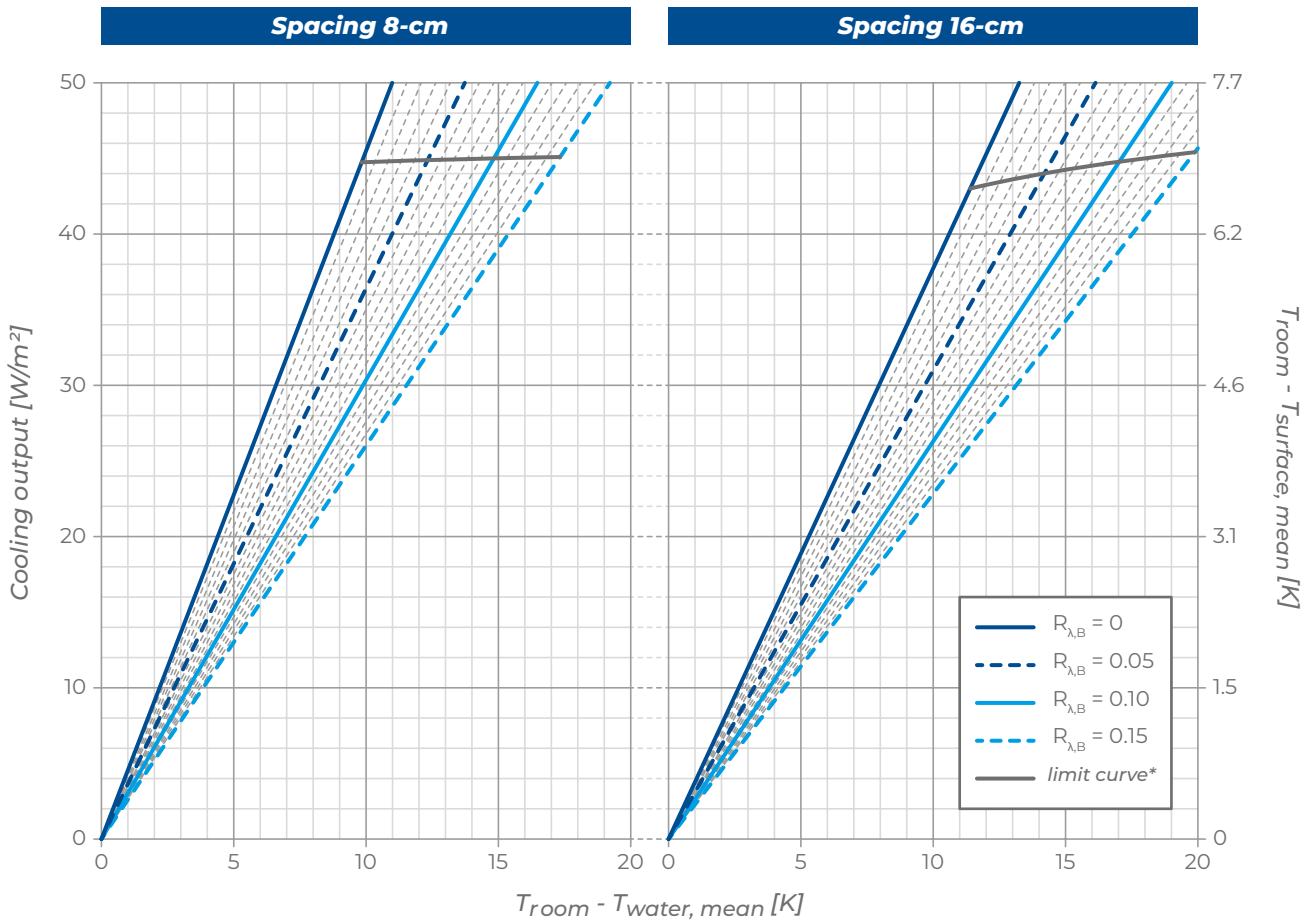

*valid only for room temperature = 26 °C



Acoustic Plus is a traditional underfloor radiant heating and cooling system, characterised by pipe anchored to an insulated base and embedded in the screed.

Ideal for applications where it is necessary to maintain a constant ambient temperature throughout the day, it can be used in both the residential and commercial applications, particularly in buildings where the reduction of trample noise is a particularly important requirement.

The central element of the system is the Acoustic Plus studded panel made of two layers of expanded sintered polystyrene with different densities and excellent acoustic performances. The materials used and the production technology guarantee a reduction in the impact sound level of 29 dB for the 20 mm thick panel and 26 dB for the 30 mm thick panel.

The system is completed by RDZ Tech PE-X Ø 17 mm high density cross-linked polyethylene pipe and equipped with anti-oxygen barrier according to DIN 4726, the hooked clips, the open support elbows, the manifold, the Plus perimeter belt and the 4S thermo-fluidifying additive.

FEATURES

- Reduces trample noise within legal limits
- RDZ Tech pipe Ø 17 mm
- High mechanical resistance
- Suitable for residential and commercial applications
- Easy and quick installation



SECTION AND DIMENSIONS

- 1 Skirting board
- 2 Flooring
- 3 Concrete
- 4 RDZ Tech pipe Ø 17-13
- 5 Plus perimeter belt
- 6 Acoustic Plus panel
- 7 Anti-shrinkage mesh
- 8 Clip 75
- 9 Hooked clip
- 10 Substrate + levelling

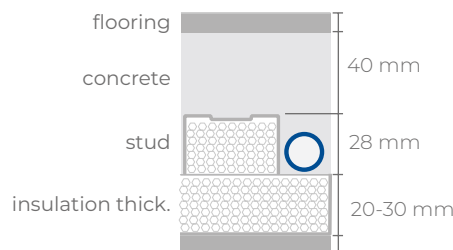
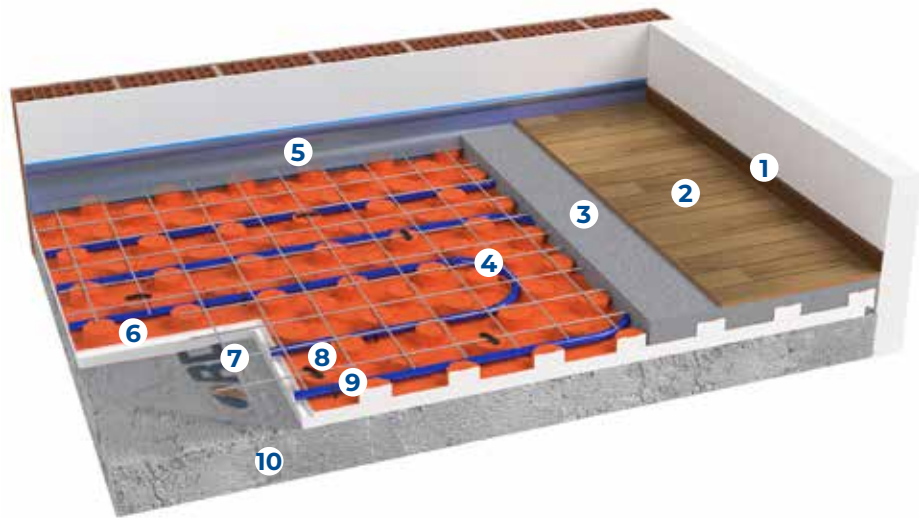

Indicative quotas

Panel thickness	20 mm	30 mm
Quote with Tiles - Parquet flooring	10 - 11 cm	11 - 12 cm
Quote with Marble - Blockboard flooring	11 - 13 cm	12 - 14 cm

Installation notes

- If the floor is in direct contact with the ground (i.e. without a sanitary void or insulating sheathing), provide a polyethylene sheet to act as a moisture barrier
- Check that the site is clear and clean.
- Ensure that the laying surface is free of protrusions that could interrupt the continuity of the insulation layer
- Check the dimensions available, taking into account the thickness of the insulation, the thickness of the screed and the thickness of the flooring chosen.
- Lay the perimeter frame and the insulation panels
- Lay the pipework as stated the project
- As a general rule, it is never necessary to bend the pipe with a bending radius of less than 12.5 cm, i.e. with a bend of less than 25°.
- Test the system and leave it under pressure until all further work has been completed.
- If necessary, install the anti-shrinkage mesh

Note: Please refer to the installation manual for more information.

■ PRODUCTS THAT COMPOSE THE SYSTEM



Acoustic Plus Panel

Acoustic Plus panel with studs made of stretch, expanded, sintered polystyrene with double density, ideal for thermal and acoustic insulation. Acoustic Plus panel is combined with a special plastic film, thickness 0.15 mm, which protects it from humidity (in compliance with EN 1264). Trample noise reduction of ΔL_w 29 dB (according to UNI EN 12354-2), dynamic rigidity $SD \leq 15 \text{ MN/m}^3$. These panels have a tongue along the perimeter to connect them for proper combination, and they have a moulded surface with studs of 28 mm, so that the pipes can be fitted into the tabs of the panel with spacing of 8.3 cm or multiples

Features

SIZE	THICKNESS	CODE
1161x663 mm	20 mm	1054040
1161x663 mm	30 mm	1054050

Panel features	Symbol	20	30	Unit	Standard
Necessary Length	L1	1161		mm	UNI EN 822
Necessary Width	W1	663		mm	UNI EN 822
Total Thickness	T4	48	58	mm	UNI EN 823
Insulation base thickness		20	30	mm	
Equivalent thickness		30.5	40.5	mm	UNI EN 1264/3
Compressibility	CP3	≤ 3		mm	UNI EN 12431
Max load on the surface		≤ 4		kPa	UNI EN 1191-2-1
Thermal conductivity at 10 °C	λ_D	0.037		W/(m·K)	UNI EN 13163
Thermal resistance base thickness	R_D	0.50	0.80	(m ² ·K)/W	UNI EN 1264:2021
Dynamic stiffness SD	SD	≤ 15	≤ 20	mN/m ³	EN 29052-1
Footstep sound absorption	ΔL_w	29*	26	dB	UNI EN ISO 140-8
Water vapour resistance factor	μ (MU)	40 ÷ 100			UNI EN 12086
Water vapour transmission	δ	0.006 ÷ 0.015		mg/(Pa·h·m)	UNI EN 12086
Dimension stability 48h / 70°C	DS(70,-)	1		%	UNI EN 1604
Reaction to fire class		F		Euroclass	UNI EN 13501-1
Long term water absorption by partial immersion	Wlp	≤ 0.5		kg/m ²	UNI EN 12087
Long-term water absorption by total immersion	WL(T)	≤ 3		%	UNI EN 12087
Limit of operating temperature		70		°C	
Weight		660	760	g	
Specific heat	C	1450		J/kg·°k	UNI EN 10456
HIPS Foil thickness		140 ÷ 150		μm	
*: according to UNI EN 12354-2 with floating floors of 80 kg/m ²					
Declaration according to UNI EN 13163					
20 mm - Class: EPS T, Identification code: EPS T-EN 13163-T0-L3-W3-S2-P5-DS(70,-)1-WL(T)3-SD15-CP3-MU(40÷100)					
30 mm - Class: EPS T, Identification code: EPS T-EN 13163-T0-L3-W3-S2-P5-DS(70,-)1-WL(T)3-SD20-CP3-MU(40÷100)					



RDZ Tech PE-Xa Pipe Ø 17 Interior Layer

RDZ Tech PE-Xa pipe Ø 17-13 made of high-density cross-linked polyethylene with the oxygen barrier between the PE-X layer and an outer layer made of PE, which ensures further protection during installation in the building site. The layers are combined thanks to a special glue.

TYPE	ROLL	CODE
PE-Xa	240 m	1013840
PE-Xa	600 m	1013850

Note: for further technical data see page 178



Plus perimeter belt

Plus perimeter belt is the edge insulation, which absorbs floor expansions and acts as thermo-acoustic insulation for the walls.

SIZE	CODE
5x150 mm	1071250



Hooked clip

Hooked clips made of plastic material to ensure secure positioning of the pipe on the insulating panels.

PACKAGE	CODE
100 pieces	1017000



Open Elbow

Open elbow Ø 17 made of plastic material. It is used to support the pipes near the manifolds vertically and to protect them from any damage.

SIZE	CODE
Ø 17 mm	1130517



Thermofluidifying Additive 4S

Superfluxing, multidosage, water reducing admixture for concrete to increase its workability and to improve its mechanical properties and thermal conductivity. It is a product which conforms to EN 934-2; T3.1 - 3.2.

SIZE	CODE
10 liters	1091911
20 liters	1091921

Tips for material calculation

Needed products	Requirements
Acoustic Plus Panel	Area to be covered +3%
RDZ Tech pipe Ø 17 mm	Depending on the average pitch. Total = area / pitch [m ² /m]
Plus perimeter belt	1 metre per m ²
Open elbow Ø 17	2 for each circuit
Hooked clip	5 for each circuit

Optional products	Requirements
Fibreglass Mesh	Area to be covered +10%
RDZ Fiber (polypropylene fibres)	1 kg per 16 m ²
Clip 75	To be used only if anti-shrinkage mesh is used. 5 clips/m ²
Humidity Barrier Sheet	Surface to be covered +20%
Thermofluidifying Additive 4S	Approx. 0.2 litres per m ²
Inhibitor XR20	2% of ENTIRE water content
Biocide XR40	1% of ENTIRE water content

Manifolds, heads, accessories and optional products (from page 160).

Note: The requirements in the table are indicative. Please refer to the construction project for confirmation..

THERMAL OUTPUT OF THE SYSTEM

Thermal output in heating

Input data			
Screed coverings above the pipe	s_U	0.045	m
Heat conductivity of screed	λ_E	1.2	W(m·k)
Piper external diameter	d_o	0.017	m
Pipe wall thickness	s_R	0.002	m
Pipe heat conductivity	λ_R	0.35	W(m·k)

K_H [m ² ·k]																
$R_{\lambda,B}$ [m ² ·k/W]																
T cm	0.00	0.01	0.02	0.03	0.04	0.05	0.06	0.07	0.08	0.09	0.10	0.11	0.12	0.13	0.14	0.15
8.3	6.556	6.111	5.723	5.383	5.081	4.812	4.571	4.352	4.154	3.974	3.809	3.656	3.516	3.386	3.266	3.154
16.6	5.144	4.834	4.565	4.328	4.119	3.934	3.760	3.603	3.461	3.331	3.213	3.099	2.994	2.896	2.806	2.722
24.9	4.067	3.850	3.663	3.500	3.356	3.230	3.105	2.994	2.893	2.802	2.719	2.634	2.555	2.482	2.415	2.353

$R_{\lambda,B}$: Heat conduction resistance of the floor covering
 T: Pipe spacing
 K_H : Equivalent thermal transmission coefficient

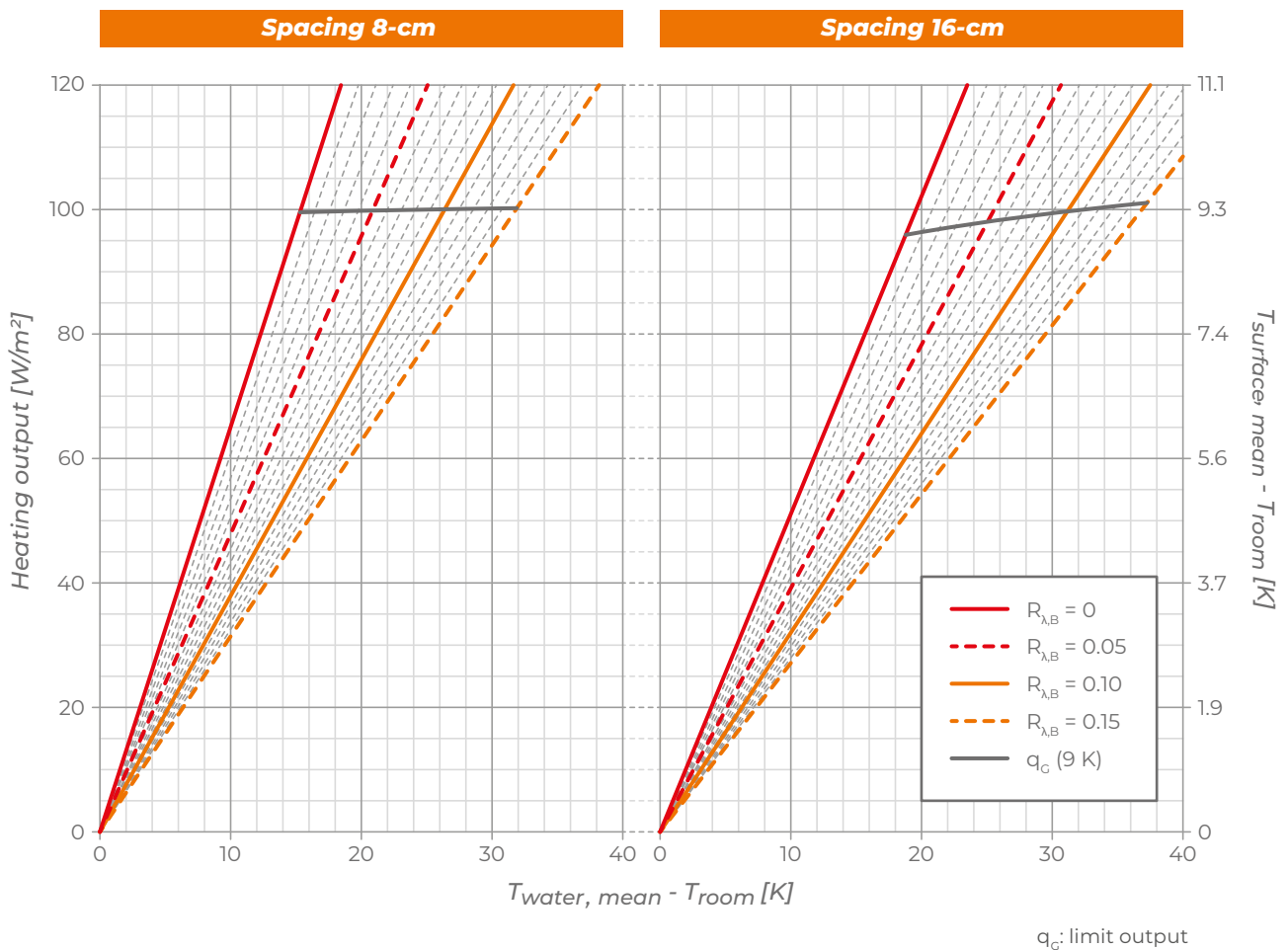

q_G : limit output

Thermal output in cooling

Input data			
Screed coverings above the pipe	s_U	0.045	m
Heat conductivity of screed	λ_E	1.2	W(m·k)
Piper external diameter	d_o	0.017	m
Pipe wall thickness	s_R	0.002	m
Pipe heat conductivity	λ_R	0.35	W(m·k)

K_H [m ² ·k]																
$R_{\lambda,B}$ [m ² ·k/W]																
T cm	0.00	0.01	0.02	0.03	0.04	0.05	0.06	0.07	0.08	0.09	0.10	0.11	0.12	0.13	0.14	0.15
8.3	4.551	4.334	4.138	3.958	3.793	3.642	3.502	3.372	3.252	3.140	3.035	2.938	2.846	2.760	2.679	2.602
16.6	3.774	3.616	3.471	3.338	3.214	3.099	2.992	2.893	2.799	2.712	2.630	2.552	2.479	2.410	2.345	2.283
24.9	3.135	3.022	2.916	2.818	2.727	2.641	2.560	2.484	2.413	2.345	2.281	2.221	2.163	2.109	2.057	2.008

$R_{\lambda,B}$: Heat conduction resistance of the floor covering
 T: Pipe spacing
 K_H : Equivalent thermal transmission coefficient

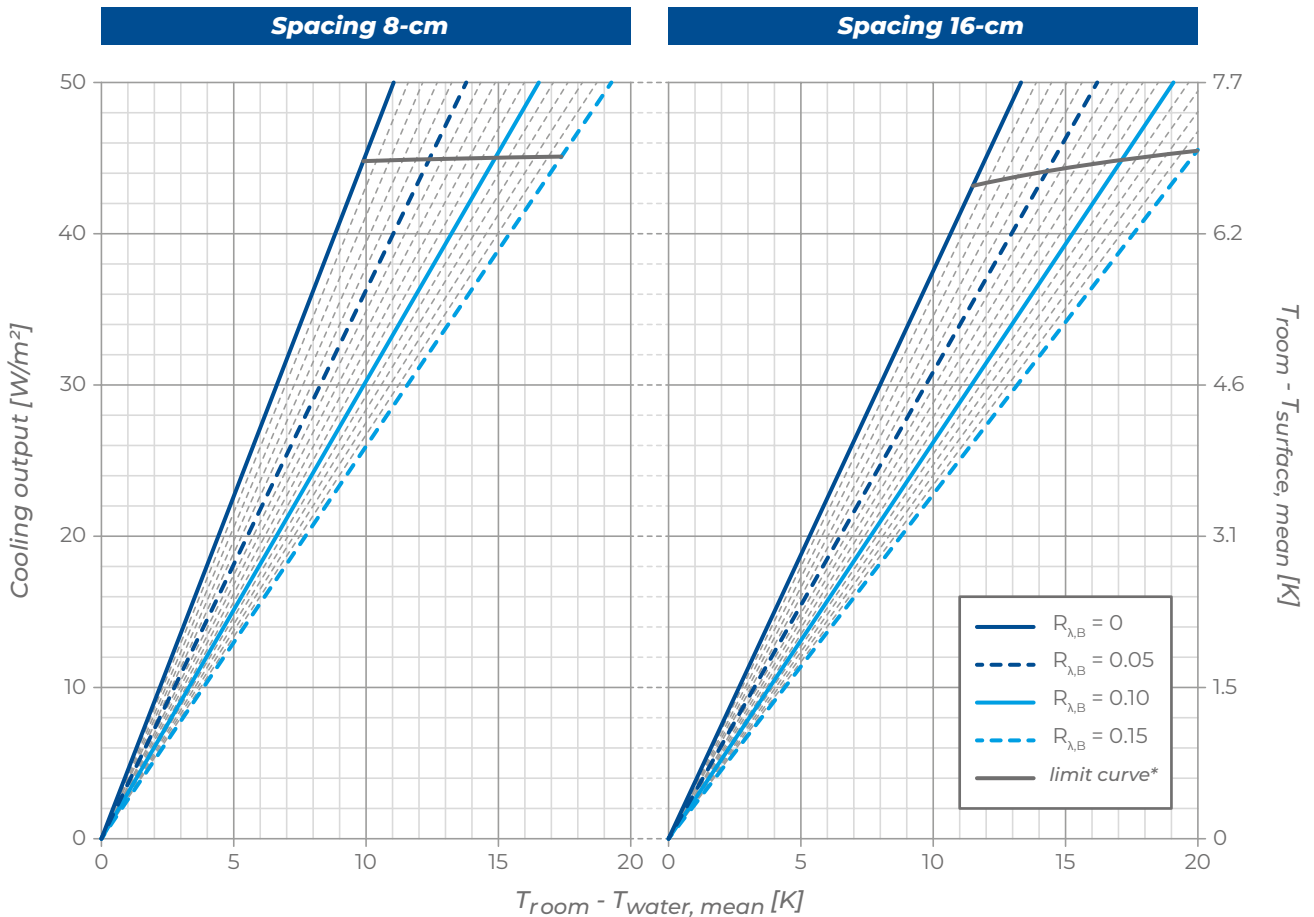

*valid only for room temperature = 26 °C



AcuRapid is an underfloor radiant heating and cooling system, characterised by excellent acoustic properties and quick and easy installation.

The central element of the system is the Acurapid B panel made of EPS T elasticised sintered expanded polystyrene, covered with a special screen-printed fabric to facilitate the installation of the Rapid PE-RT pipe Ø 17 mm.

Available in the 20 and 30 mm versions, it has elastic properties that make it possible to obtain average sound reduction of 26 and 28 dB(A) with a screed of 100 kg/m², according to UNI EN 12354-2.

The installation of AcuRapid is quick and easy thanks to the tear-off connection system: the pipe is wrapped in a band with tiny hooks arranged in a helical pattern that adheres firmly to the panel without the need for additional fastening components.

The system is completed with the Plus perimeter belt, the manifold, the open support elbows and the 4S thermofluidifying additive.

FEATURES

- Tear-off fastening of Rapid PE-RT pipe Ø 17 mm
- Very good acoustic performances
- Suitable for residential and commercial applications
- Quick and easy to install



SECTION AND DIMENSIONS

- 1 Skirting board
- 2 Flooring
- 3 Concrete
- 4 Rapid PE-RT pipe \varnothing 17-13
- 5 Plus perimeter belt
- 6 Acurapid B panel
- 7 Substrate + levelling

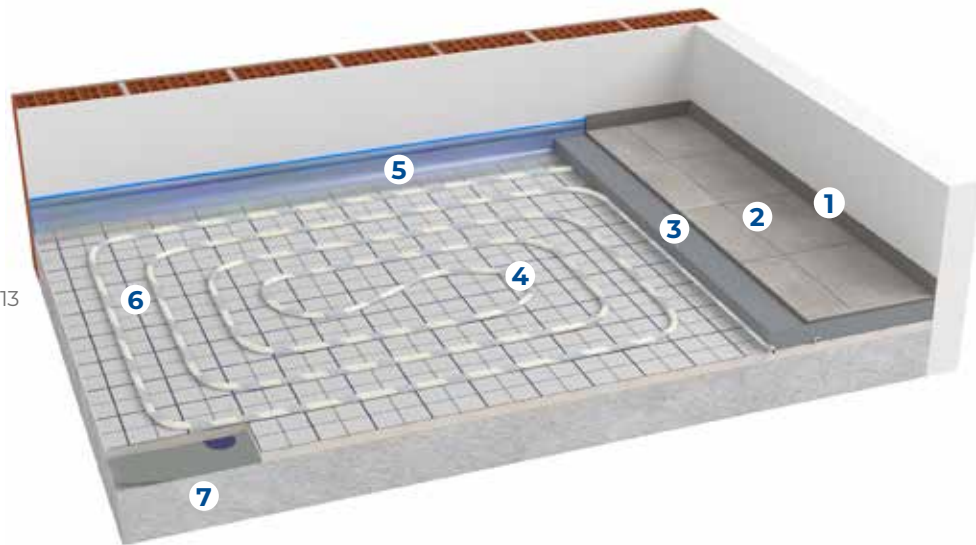

Indicative quotas

Panel thickness	20 mm	30 mm
Quote with Tiles - Parquet flooring	9 - 10 cm	10 - 11 cm
Quote with Marble - Blockboard flooring	10 - 11 cm	11 - 12 cm

Installation notes

- If the floor is in direct contact with the ground (i.e. without a sanitary void or insulating sheathing), provide a polyethylene sheet to act as a moisture barrier
- Check that the site is clear
- Check the available dimensions, taking into consideration the thickness of the insulation, screed and flooring chosen.
- Lay the perimeter belt and the insulation panels
- Lay the pipe as stated in the project
- Usually, it's not necessary to bend the pipe with a bending radius of less than 12.5 cm, i.e. with a laying pitch of less than 25 cm
- Test the system and leave it under pressure until all subsequent works are completed

Note: Please refer to the installation manual for more information.

PRODUCTS THAT COMPOSE THE SYSTEM



AcuRapid B Panel

Smooth panels in rolls made of ESPT elastic expanded sintered polystyrene. It is covered with a special protective film barrier which is suitable for attaching the pipe thanks to its hook fastening tape. The foil overlaps on two sides, therefore the foil layer is continuous.

SIZE	THICKNESS	CODE
1x10 m	20 mm	1045442
1x10 m	30 mm	1045552

Panel features	Level/ Class	Code		Unit	Standard
		1045442	1045552		
Necessary length	L(3)	10000 (± 3)		mm	UNI EN 13163:2015
Necessary width	W(3)	1000 (± 3)			
Total thickness	T(2)	20 (-1, +3)	30 (-1, +3)		
Insulation base thickness		20 (-1, +3)	30 (-1, +3)		
Equivalent thickness		20 (-1, +3)	30 (-1, +3)		
Compressibility	CP2	≤ 2		Kpa	
Maximum applicable load on the surface		≤ 5			
Thermal conductivity at 10 °C		λ_D 0.040		W/(m·K)	
Thermal resistance calculated on the equivalent thickness		R _D 0.50	R _D 0.75	(m ² ·K)/W	
Dynamic stiffness		≤ 30	≤ 20	mN/m ³	
Dimensional stability 23 °C / 50 % U.R.		± 0.5		%	
Water absorption by total immersion		≤ 5		%	
Durability of reaction to fire performance against aging/degradation	The reaction to fire performance for EPS does not reduce over time.				
Durability of thermal resistance against aging/degradation	The thermal conductivity of EPS does not change over time.				
Reaction to fire class	Euroclass E				
Maximum operating temperature		70		°C	
Sound absorption (with 100 Kg/m ² screed)		26	28	dB(A)	EN 12354-2
Unique identification code of the product-type					
Thickness 20 mm: EPS-EN 13163:2015-L3-W3-T1-S2-P5-DS(N)2-BS050-SD30-CP2-MU(20-40)					
Thickness 30 mm: EPS-EN 13163:2015-L3-W3-T1-S2-P5-DS(N)2-BS050-SD20-CP2-MU(20-40)					



Rapid PE-RT Pipe Ø 17

RDZ 17-13 polyethylene pipe with EVOH oxygen diffusion barrier which complies with DIN 4726. It consists in 5 layers PE-RT/EVOH/PE-RT ensuring outstanding flexibility & easy handling. A micro-interlocking band is helically wound around the pipe.

SIZE	TYPE	CODE
Ø 17-13 mm	PE-RT	1013890



Plus perimeter belt

Plus perimeter belt is the edge insulation, which absorbs floor expansions and acts as thermo-acoustic insulation for the walls.

SIZE	CODE
5x150 mm	1071250



Open Elbow

Open elbow Ø 17 made of plastic material. It is used to support the pipes near the manifolds vertically and to protect them from any damage.

SIZE	CODE
Ø 17 mm	1130517



Thermofluidifying Additive 4S

Superfluxing, multidosage, water reducing admixture for concrete to increase its workability and to improve its mechanical properties and thermal conductivity. It is a product which conforms to EN 934-2; T3.1 - 3.2.

SIZE	CODE
10 liters	1091911
20 liters	1091921

Tips for material calculation

Needed products	Requirements
AcuRapid B Panel	Area to be covered +5%
Rapid Pe-RT pipe Ø 17 mm	Depending on the average pitch. Total = area / pitch [m ² /m]
Plus perimeter belt	1 metre per m ²
Open elbow Ø 17	2 for each circuit

Optional products	Requirements
RDZ Fiber (polypropylene fibres)	1 kg per 16 m ²
Humidity Barrier Sheet	Area to be covered +20%
Thermofluidifying Additive 4S	Approx. 0.2 litres per m ²
Inhibitor XR20	2% of ENTIRE water content
Biocide XR40	1% of ENTIRE water content

Manifolds, heads, accessories and optional products (from page 160).

Note: The requirements in the table are indicative. Please refer to the construction project for confirmation

THERMAL OUTPUT OF THE SYSTEM

Thermal output in heating

Input data			
Screed coverings above the pipe	s_U	0.045	m
Heat conductivity of screed	λ_E	1.2	W(m·k)
Piper external diameter	d_o	0.017	m
Pipe wall thickness	s_R	0.002	m
Pipe heat conductivity	λ_R	0.40	W(m·k)

K_H [m ² ·k]																
$R_{\lambda,B}$ [m ² ·k/W]																
T cm	0.00	0.01	0.02	0.03	0.04	0.05	0.06	0.07	0.08	0.09	0.10	0.11	0.12	0.13	0.14	0.15
8.3	6.811	6.332	5.917	5.554	5.233	4.948	4.693	4.463	4.255	4.066	3.893	3.734	3.587	3.452	3.327	3.211
16.6	5.345	5.009	4.719	4.466	4.243	4.045	3.860	3.694	3.544	3.408	3.284	3.165	3.054	2.953	2.859	2.772
24.9	4.225	3.990	3.787	3.611	3.457	3.321	3.188	3.070	2.963	2.867	2.779	2.689	2.607	2.531	2.461	2.396

$R_{\lambda,B}$: Heat conduction resistance of the floor covering
 T: Pipe spacing
 K_H : Equivalent thermal transmission coefficient

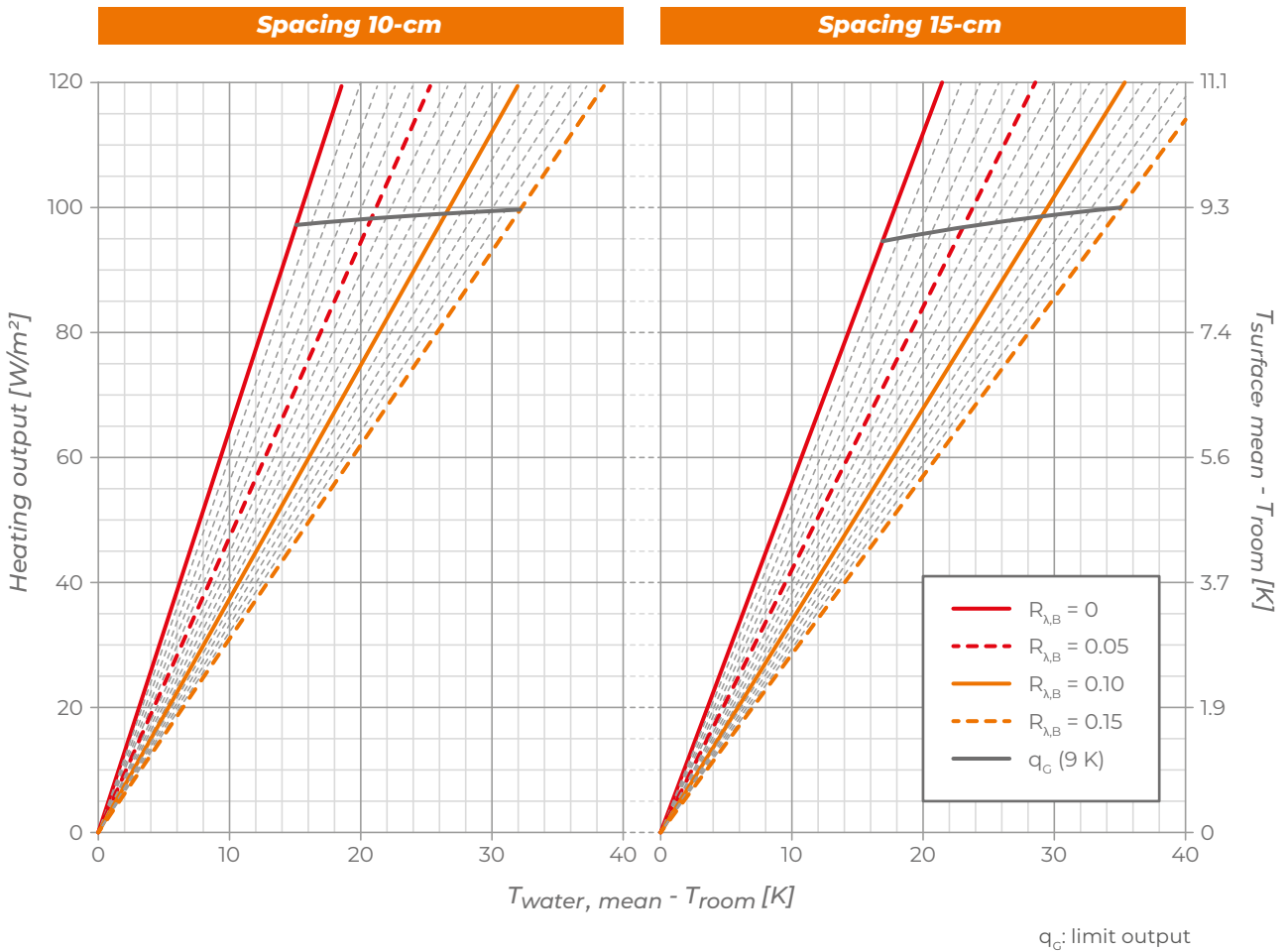

Thermal output in cooling

Input data			
Screed coverings above the pipe	s_U	0.045	m
Heat conductivity of screed	λ_E	1.2	W(m·k)
Piper external diameter	d_o	0.017	m
Pipe wall thickness	s_R	0.002	m
Pipe heat conductivity	λ_R	0.40	W(m·k)

K_H [$m^2 \cdot k$]																
$R_{\lambda,B}$ [$m^2 \cdot k/W$]																
T cm	0.00	0.01	0.02	0.03	0.04	0.05	0.06	0.07	0.08	0.09	0.10	0.11	0.12	0.13	0.14	0.15
8.3	4.672	4.444	4.237	4.049	3.877	3.718	3.573	3.438	3.313	3.197	3.088	2.987	2.892	2.803	2.720	2.641
16.6	3.876	3.709	3.557	3.416	3.286	3.165	3.054	2.949	2.852	2.761	2.675	2.595	2.519	2.448	2.380	2.316
24.9	3.221	3.101	2.989	2.885	2.788	2.698	2.613	2.533	2.458	2.387	2.321	2.258	2.198	2.141	2.087	2.036

$R_{\lambda,B}$: Heat conduction resistance of the floor covering
 T: Pipe spacing
 K_H : Equivalent thermal transmission coefficient

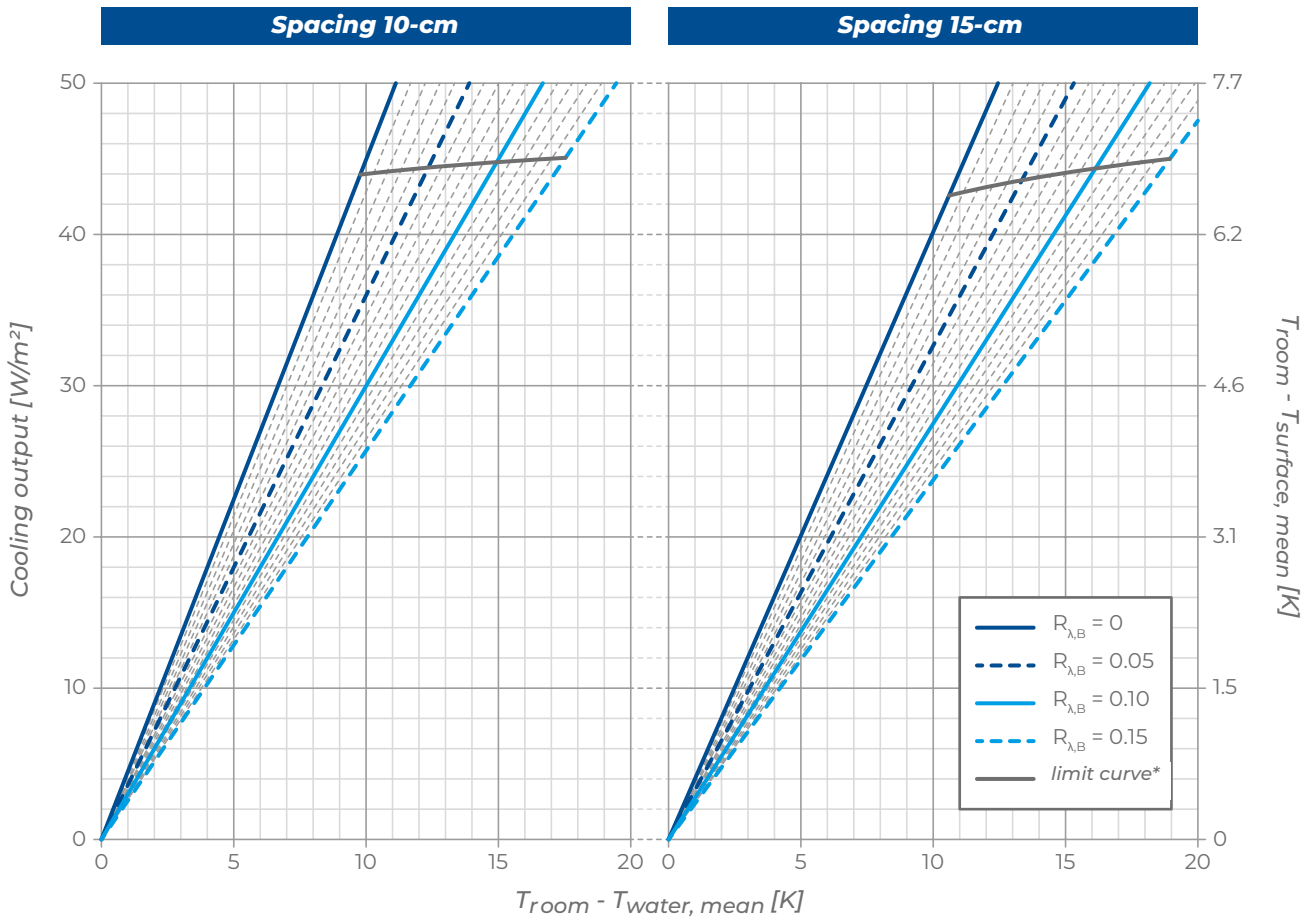

*valid only for room temperature = 26 °C

SMOOTH COVER HP SYSTEM



Smooth Cover HP is a traditional underfloor radiant heating and cooling system, characterised by pipes anchored to an insulated base by special fixing clips and embedded in the screed.

Invisible and efficient, it can be used in both residential and commercial applications and it is ideal for applications where it is necessary to maintain a constant room temperature throughout the day.

The central element of the system is the Smooth Cover HP panel made of sintered polystyrene with graphite compliant with UNI EN 13163, with high mechanical resistance and characterised by special grooves on the surface that facilitate the laying of the pipe. Available in a wide range of thicknesses (24, 39, 47 and 62 mm), it satisfies a variety of requirements and, thanks to the presence of graphite, offers excellent thermal insulation performance even with reduced overall dimensions.

The system is completed by RDZ Tech pipe in PE-X Ø 17 or 20 mm, in high-density cross-linked polyethylene and provided with anti-oxygen barrier according to DIN 4726, the clips for anchoring the pipe to be applied by a special clip fastener, the support curves, the manifold, the Plus perimeter belt and the 4S thermo-fluidifying additive.

FEATURES

- Smooth panel in sintered polystyrene with graphite
- RDZ Tech pipe Ø 17 mm and Ø 20 mm
- Excellent thermal insulation
- Available in thicknesses 24-39-47-62 mm
- Suitable for residential and commercial applications
- Easy and quick installation



SECTION AND DIMENSIONS

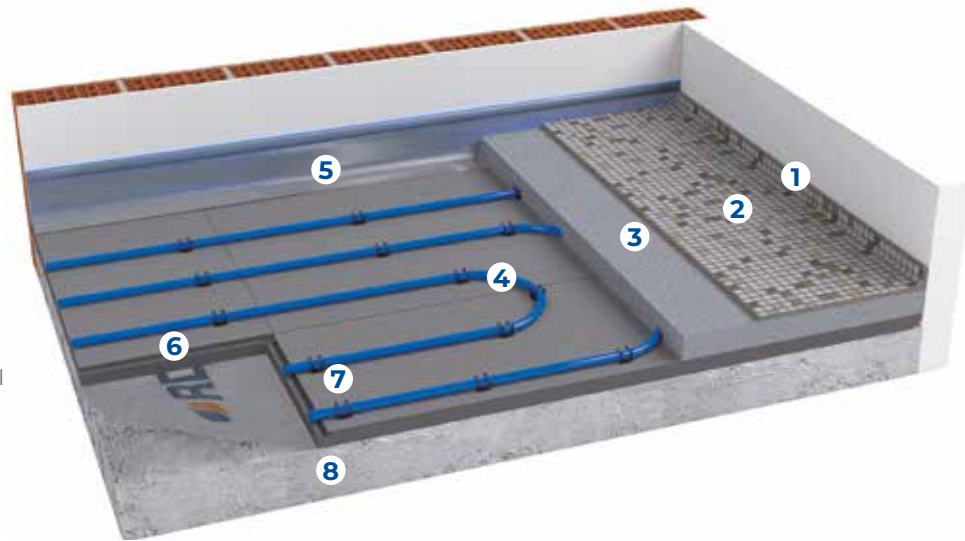

- 1 Skirting board
- 2 Flooring
- 3 Concrete
- 4 RDZ Tech pipe Ø 20-16
- 5 Plus perimeter belt
- 6 Smooth Cover HP panel
- 7 Fixing clip
- 8 Substrate + levelling

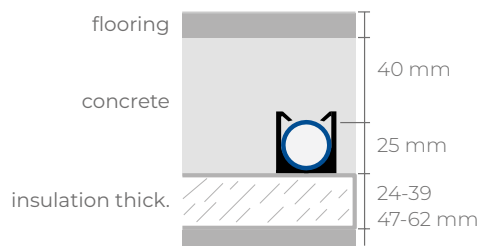

Indicative quotas

Panel thickness	24 mm	39 mm	47 mm	62 mm
Quote with Tiles - Parquet flooring	9.6 - 10.6 cm	11.1 - 12.1 cm	11.9 - 12.9 cm	13.4 - 14.4 cm
Quote with Marble - Blockboard flooring	10.6 - 12.6 cm	12.1 - 14.1 cm	12.9 - 14.9 cm	14.4 - 16.4 cm

Installation notes

- If the floor is in direct contact with the ground (i.e. without a sanitary void or insulating sheathing), provide a polyethylene sheet to act as a moisture barrier.
- Check that the site is clear
- Check the dimensions available, taking into consideration the thickness of the insulation, screed and flooring chosen
- Lay the perimeter belt and the insulation panels
- Lay the pipe fixing clips according to the circuit paths specified in the project
- Lay the pipe
- Usually, it's not necessary to bend the pipe with a bending radius of less than 12.5 cm, i.e. with a laying pitch of less than 25 cm
- Test the system and leave it under pressure until all subsequent works are completed

Note: Please refer to the installation manual for more information.

PRODUCTS THAT COMPOSE THE SYSTEM

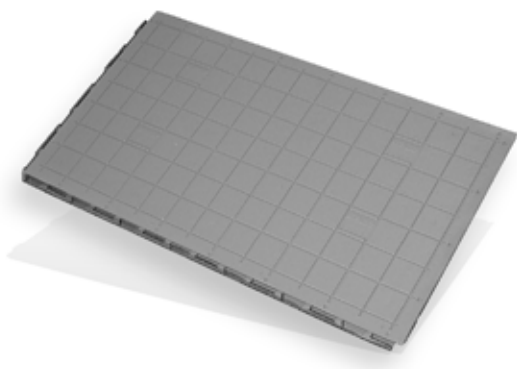

Smooth Cover HP Panel

Smooth Cover HP panel is made of waterproof expanded polystyrene with graphite, produced in conformity with UNI EN 13163, with closed-cell structure, which has high compression strength. It is combined with a special plastic film in order to protect it from humidity in compliance with EN 1264. These panels have a tongue along the perimeter to connect them for proper combination. Spacing of 8.3 cm.

SIZE	THICKNESS	CODE
1161x663 mm	24 mm	1056424
1161x663 mm	39 mm	1056439
1161x663 mm	47 mm	1056447
1161x663 mm	62 mm	1056462

Panel features	Symbol	24	39	47	62	Unit	Standard
Necessary length	L1	1161				mm	UNI EN 822
Necessary width	W1	663				mm	UNI EN 822
Total thickness	T4	24	39	47	62	mm	UNI EN 823
Compressive stress at 10% deformation	CS(10)	120				kPa	UNI EN 826
Compressive stress at 5% deformation		85				kPa	
Compressive stress at 2% deformation		52				kPa	
Thermal conductivity at 10 °C	λ_D	0.031				W/(m·K)	UNI EN 13163
Thermal resistance	R_D	0.75	1.25	1.50	2.00	(m ² ·K)/W	UNI EN 13163
Water vapour diffusion resistance factor	μ (MU)	30 ÷ 70					UNI EN 12086
Water vapour permeability	δ	0.010 ÷ 0.024				mg/(Pa·h·m)	UNI EN 12086
Dimension stability 48h / 70°C	DS(70,-)	≤ 1				%	UNI EN 1604
Fire reaction		F				Euroclass	UNI EN 13501-1
Long term water absorption by partial immersion	W1p	0.5				kg/m ²	UNI EN 12087
Long-term water absorption by total immersion	WL(T)	≤ 3				%	UNI EN 12087
Limit of operating temperature		70				°C	
Weight		485	786	949	1250	g	
Specific heat	C	1210				J/kg·°k	UNI EN 10456
HIPS Foil thickness		150				µm	
Declaration according to UNI EN 13163							
Unique identification code of the product-type: EPS-EN 13163-T2-L3-W3-S2-P5-BS 170-CS(10)120-DS(70,-)1-WL(T)3-MU(30-70)							



RDZ Tech PE-Xa Pipe Ø 17 Interior Layer

RDZ Tech PE-Xa pipe Ø 17-13 made of high-density cross-linked polyethylene with the oxygen barrier between the PE-X layer and an outer layer made of PE, which ensures further protection during installation in the building site. The layers are combined thanks to a special glue.

TYPE	ROLL	CODE
PE-Xa	240 m	1013840
PE-Xa	600 m	1013850

Note: for further technical data see page 178



RDZ Tech PE-Xc Pipe Ø 20 Interior Layer

RDZ Tech pipe Ø 20-16 mm made of high-density electrophysically cross-linked polyethylene with oxygen barrier. This pipe is produced according to DIN EN ISO 15875/2 and DIN 4726.

TYPE	ROLL	CODE
PE-Xc	240 m	1012240
PE-Xc	600 m	1012600



Plus perimeter belt

Plus perimeter belt is the edge insulation, which absorbs floor expansions and acts as thermo-acoustic insulation for the walls.

SIZE	CODE
5x150 mm	1071250



Fixing clips for 24 mm panels

These clips shall be used with relevant fixer in systems with 24 mm smooth panels and piping Ø 17 or Ø 20 mm.

SIZE	CODE
For pipe Ø 17 or 20 mm	1017520



Fixing clips for 39-62 mm panels

These clips shall be used with relevant fixer in systems with 39/62-mm smooth panels and piping Ø 17 or Ø 20 mm.

SIZE	CODE
For pipe Ø 17 or 20 mm	1017540



Open Elbow

Open elbow made of plastic material. It is used to support the pipes near the manifolds vertically and to protect them from any damage.

SIZE	CODE
Ø 17 mm	1130517
Ø 20 mm	1140020



Thermofluidifying Additive 4S

Superfluxing, multidosage, water reducing admixture for concrete to increase its workability and to improve its mechanical properties and thermal conductivity. It is a product which conforms to EN 934-2; T3.1 - 3.2.

SIZE	CODE
10 liters	1091911
20 liters	1091921

Tips for material calculation

Needed products	Requirements
Smooth Cover HP panel	Area to be covered +3%
RDZ Tech pipe Ø 17 or Ø 20 mm	Depending on the average pitch. Total = area / pitch [m ² /m]
Plus perimeter belt	1 metre per m ²
Open elbow Ø 17 or Ø 20	2 for each circuit
Fixing clips for 24-39 mm panels	3 per metre of pipe
Fixing clips for 47-62 mm panels	3 per metre of pipe
Humidity Barrier Sheet Grid 10	Area to be covered +20%

Optional products	Requirements
Humidity Barrier Sheet	Area to be covered +20%
Thermofluidifying Additive 4S	Approx. 0.2 litres per m ²
Inhibitor XR20	2% of ENTIRE water content
Biocide XR40	1% of ENTIRE water content

Manifolds, heads, accessories and optional products (from page 160).

Note: The requirements in the table are indicative. Please refer to the construction project for confirmation

THERMAL OUTPUT OF THE SYSTEM

Thermal output in heating

Input data			
Screed coverings above the pipe	s_U	0.045	m
Heat conductivity of screed	λ_E	1.2	W(m·k)
Piper external diameter	d_a	0.017	m
Pipe wall thickness	s_R	0.002	m
Pipe heat conductivity	λ_R	0.35	W(m·k)

K_H [m ² ·k]																
$R_{\lambda,B}$ [m ² ·k/W]																
T cm	0.00	0.01	0.02	0.03	0.04	0.05	0.06	0.07	0.08	0.09	0.10	0.11	0.12	0.13	0.14	0.15
8.3	6.811	6.332	5.917	5.554	5.233	4.948	4.693	4.463	4.255	4.066	3.893	3.734	3.587	3.452	3.327	3.211
16.6	5.345	5.009	4.719	4.466	4.243	4.045	3.860	3.694	3.544	3.408	3.284	3.165	3.054	2.953	2.859	2.772
24.9	4.225	3.990	3.787	3.611	3.457	3.321	3.188	3.070	2.963	2.867	2.779	2.689	2.607	2.531	2.461	2.396

$R_{\lambda,B}$: Heat conduction resistance of the floor covering
 T: Pipe spacing
 K_H : Equivalent thermal transmission coefficient

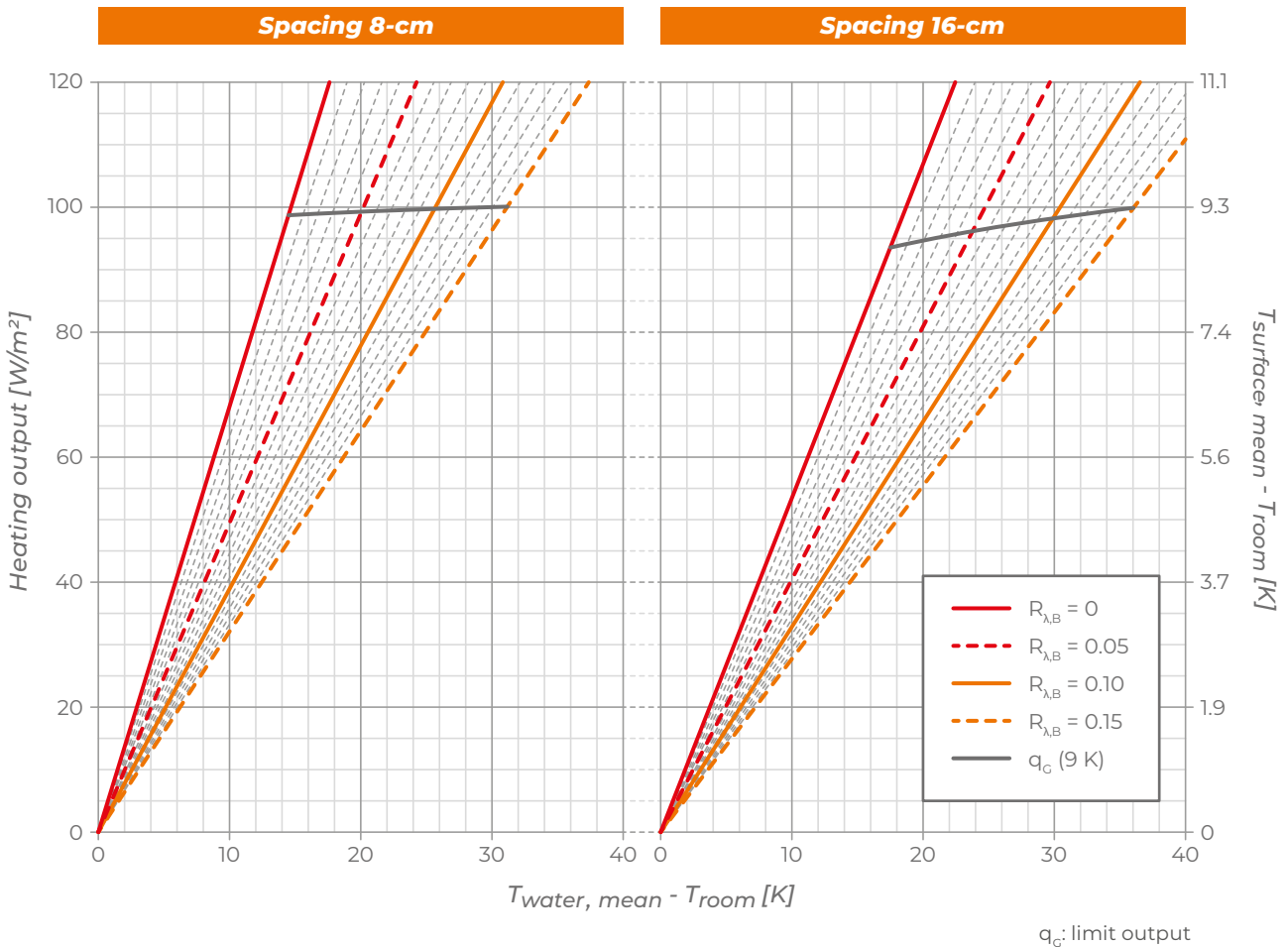

Thermal output in cooling

Input data			
Screed coverings above the pipe	s_U	0.045	m
Heat conductivity of screed	λ_E	1.2	W(m·k)
Piper external diameter	d_a	0.017	m
Pipe wall thickness	s_R	0.002	m
Pipe heat conductivity	λ_R	0.35	W(m·k)

K_H [m ² ·k]																
$R_{\lambda,B}$ [m ² ·k/W]																
T cm	0.00	0.01	0.02	0.03	0.04	0.05	0.06	0.07	0.08	0.09	0.10	0.11	0.12	0.13	0.14	0.15
8.3	4.672	4.444	4.237	4.049	3.877	3.718	3.573	3.438	3.313	3.197	3.088	2.987	2.892	2.803	2.720	2.641
16.6	3.876	3.709	3.557	3.416	3.286	3.165	3.054	2.949	2.852	2.761	2.675	2.595	2.519	2.448	2.380	2.316
24.9	3.221	3.101	2.989	2.885	2.788	2.698	2.613	2.533	2.458	2.387	2.321	2.258	2.198	2.141	2.087	2.036

$R_{\lambda,B}$: Heat conduction resistance of the floor covering
 T: Pipe spacing
 K_H : Equivalent thermal transmission coefficient

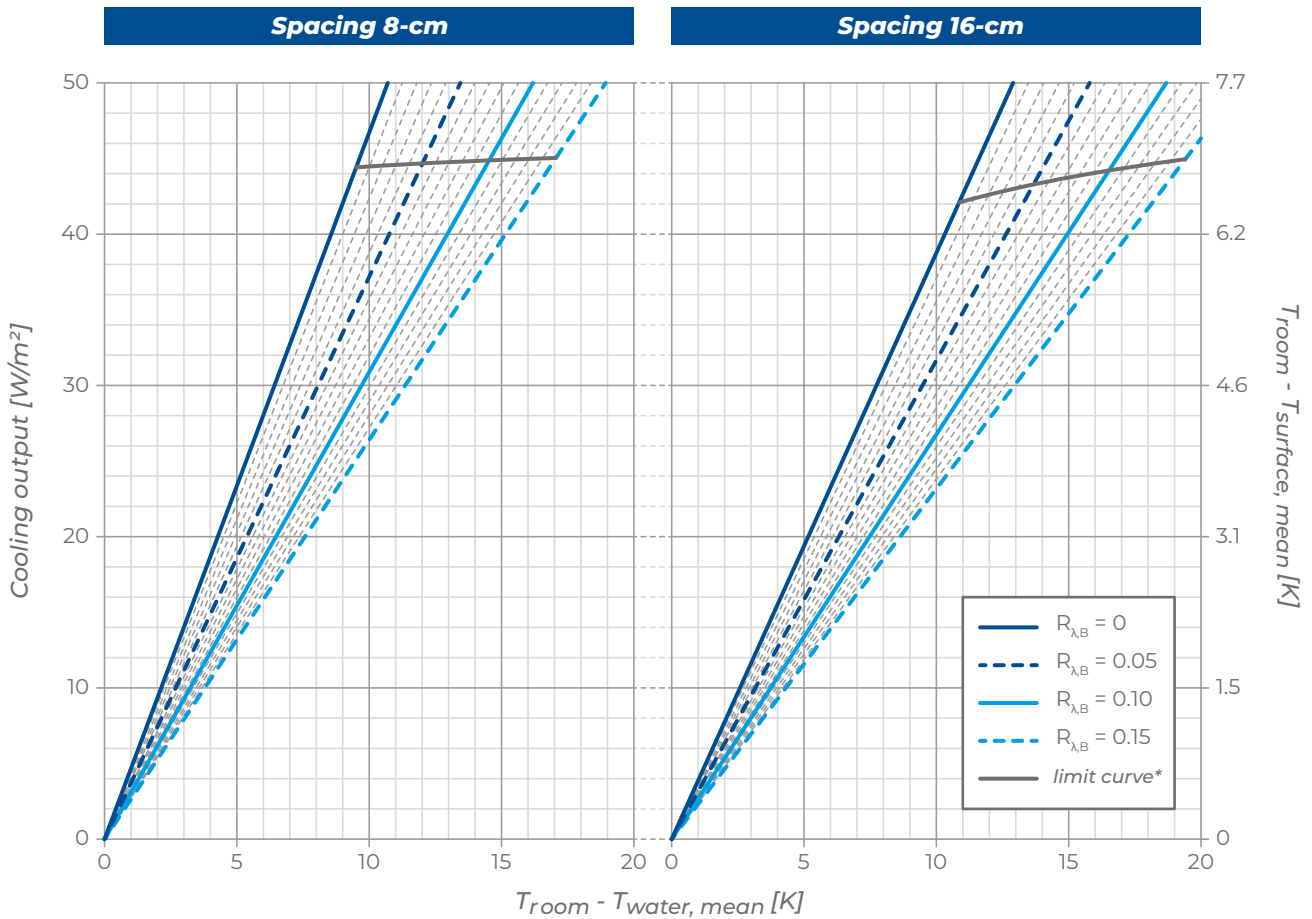

*valid only for room temperature = 26 °C



New Plus is a traditional underfloor radiant heating and cooling system, characterised by pipes anchored to an insulated base and embedded in the screed.

Distinguished by a total footprint of 7.3 cm (including 4 cm of screed, excluding flooring), it is ideal for new constructions, renovations and all applications where it is necessary to reduce the thickness occupied by the radiant system.

The central element of the system is the New Plus waterproof expanded polystyrene studded panel produced in compliance with UNI EN 13163, with closed-cell structure, with dimensions 1000x500x12.5 mm. Thanks to the flooring with plastic film for protection in compliance with EN 1264 and for greater resistance to deformation due to footsteps and thanks to the presence of practical joints on all four sides, it guarantees easy, fast and safe installation.

The system is completed by RDZ Tech PE-X pipe Ø 17 mm made of high-density cross-linked polyethylene and equipped with anti-oxygen barrier according to DIN 4726, the hooked clips, the open support elbows, manifold, the Plus perimeter belt and the 4S thermo-fluidifying additive.

FEATURES

- Small footprint
- RDZ Tech Ø 17 mm
- High mechanical resistance of the panel
- Suitable for residential and commercial applications
- Quick and easy installation



SECTION AND DIMENSIONS

- 1 Skirting board
- 2 Flooring
- 3 Concrete
- 4 RDZ Tech pipe Ø 17-13
- 5 Plus perimeter belt
- 6 New Plus panel
- 7 Anti-shrinkage mesh
- 8 Hooked clip
- 9 Clip 75
- 10 Substrate + levelling

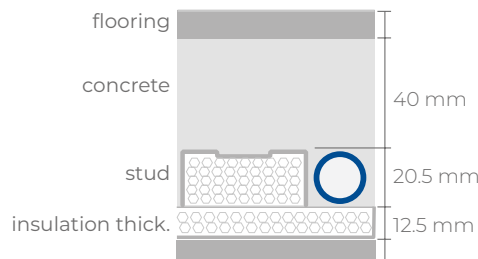
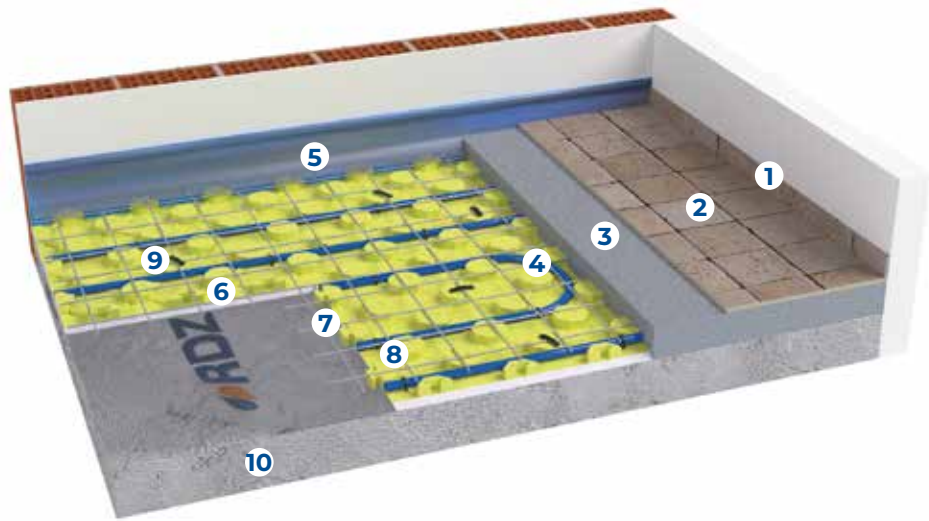

Indicative quotas

Panel thickness	12.5 mm
Quote with Tiles - Parquet flooring	8.3 - 9.3 cm
Quote with Marble - Blockboard flooring	9.3 - 11.3 cm

Installation notes

- If the floor is in direct contact with the ground (i.e. without a sanitary void or insulating sheathing), provide a polyethylene sheet to act as a moisture barrier.
- Check that the site is clear
- Check the dimensions available, taking into consideration the thickness of the insulation, screed and flooring chosen
- Lay the perimeter belt and the insulating panels (where necessary, use the special small blocks to anchor the panel to the substrate)
- Lay the pipe as stated in the project
- Usually, it's not necessary to bend the pipe with a bending radius of less than 12.5 cm, i.e. with a laying pitch of less than 25 cm
- Test the system and leave it under pressure until all subsequent works are completed
- If required, install the anti-shrinkage mesh

Note: Please refer to the installation manual for more information.

■ PRODUCTS THAT COMPOSE THE SYSTEM

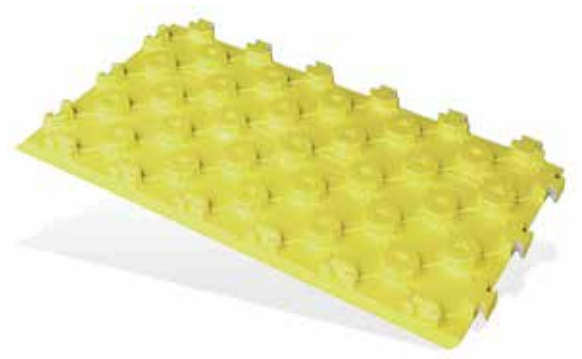

New Plus Panel

New Plus panel with studs made of waterproof moulded expanded polystyrene, produced in conformity with UNI EN 13163, with closed-cell structure, which has high compression strength. It is combined with a plastic film, thickness 0.15 mm, in order to protect it from humidity (in compliance with EN 1264) They have a moulded surface with studs of 20.5 mm so that the pipes can be fitted into the tabs of the panel at spacing of 8.3 cm.

SIZE	THICKNESS	CODE
1000x500 mm	12.5 mm	1043011

Panel features	Value	Unit	Standard
Size	1000x500x12.5	mm	UNI 822
Standard thickness	33	mm	UNI 823
Insulation base thickness	12.5	mm	
Thermal conductivity 10 °C	0.033	W/(m·K)	UNI EN 12667
Resistance to compression with 10 % deformation	250	kPa	UNI 826
Resistance to compression with 5 % deformation	180	kPa	UNI 826
Resistance to compression with 2 % deformation	130	kPa	UNI 826
Thermal resistance base thickness	0.35	(m ² ·K)/W	UNI EN 1264:2021
Equivalent total thickness	18	mm	UNI EN 1264-3
Water vapour diffusion resistance factor	40 a 100	1	UNI EN 12086
Limit of operating temperature	70	°C	
Thickness of the combined film	150	µm	
Fire reaction	F	Euroclass	EN ISO 11925-2
Declaration according to UNI EN 13163	EPS-EN13163-T1-L1-W1-S2-P4-BS350-CS(10)250-DS(70,-)1-WL(T)3-MU(40-100)		



RDZ Tech PE-Xa Pipe Ø 17 Interior Layer

RDZ Tech PE-Xa pipe Ø 17-13 made of high-density cross-linked polyethylene with the oxygen barrier between the PE-X layer and an outer layer made of PE, which ensures further protection during installation in the building site. The layers are combined thanks to a special glue.

TYPE	ROLL	CODE
PE-Xa	240 m	1013840
PE-Xa	600 m	1013850

Note: for further technical data see page 178



Plus perimeter belt

Plus perimeter belt is the edge insulation, which absorbs floor expansions and acts as thermo-acoustic insulation for the walls.

SIZE	CODE
5x150 mm	1071250



Hooked clip

Hooked clips made of plastic material to ensure secure positioning of the pipe on the insulating panels.

PACKAGE	CODE
100 pieces	1017000



Open Elbow

Open elbow Ø 17 made of plastic material. It is used to support the pipes near the manifolds vertically and to protect them from any damage.

SIZE	CODE
Ø 17 mm	1130517



Thermofluidifying Additive 4S

Superfluxing, multidosage, water reducing admixture for concrete to increase its workability and to improve its mechanical properties and thermal conductivity. It is a product which conforms to EN 934-2; T3.1 - 3.2.

SIZE	CODE
10 liters	1091911
20 liters	1091921



Small Blocks to Fix Panels

Plastic block to prevent panels from moving during pipe installation.

PACKAGE	CODE
100 pieces	1112000

Tips for material calculation

Needed products	Requirements
New Plus Panel	Area to be covered +3%
RDZ Tech pipe Ø17	Depending on the average pitch. Total = area / pitch [m ² /m]
Plus perimeter belt	1 metre per m ²
Open elbow Ø 17	2 for each circuit
Hooked clip	5 for each circuit

Optional products	Requirements
Fibreglass Mesh	Area to be covered +10%
RDZ Fiber (polypropylene fibres)	1 kg per 16 m ²
Clip 75	To be used only if anti-shrinkage mesh is used. 5 clips/m ²
Humidity Barrier Sheet	Surface to be covered +20%
Thermofluidifying Additive 4S	Approx. 0.2 litres per m ²
Inhibitor XR20	2% of ENTIRE water content
Biocide XR40	1% of ENTIRE water content

Manifolds, heads, accessories and optional products (from page 160).

Note: The requirements in the table are indicative. Please refer to the construction project for confirmation

THERMAL OUTPUT OF THE SYSTEM

Thermal output in heating

Input data			
Screed coverings above the pipe	s_U	0.045	m
Heat conductivity of screed	λ_E	1.2	W(m·k)
Piper external diameter	d_o	0.017	m
Pipe wall thickness	s_R	0.002	m
Pipe heat conductivity	λ_R	0.35	W(m·k)

K_H [$m^2 \cdot k$]																
$R_{\lambda,B}$ [$m^2 \cdot k/W$]																
T cm	0.00	0.01	0.02	0.03	0.04	0.05	0.06	0.07	0.08	0.09	0.10	0.11	0.12	0.13	0.14	0.15
8.3	6.642	6.185	5.789	5.441	5.133	4.858	4.612	4.390	4.188	4.005	3.837	3.683	3.540	3.408	3.286	3.173
16.6	5.212	4.893	4.617	4.375	4.161	3.971	3.794	3.634	3.489	3.357	3.238	3.121	3.014	2.915	2.824	2.739
24.9	4.120	3.897	3.705	3.537	3.390	3.261	3.134	3.019	2.917	2.824	2.740	2.653	2.572	2.499	2.431	2.368

$R_{\lambda,B}$: Heat conduction resistance of the floor covering
 T: Pipe spacing
 K_H : Equivalent thermal transmission coefficient

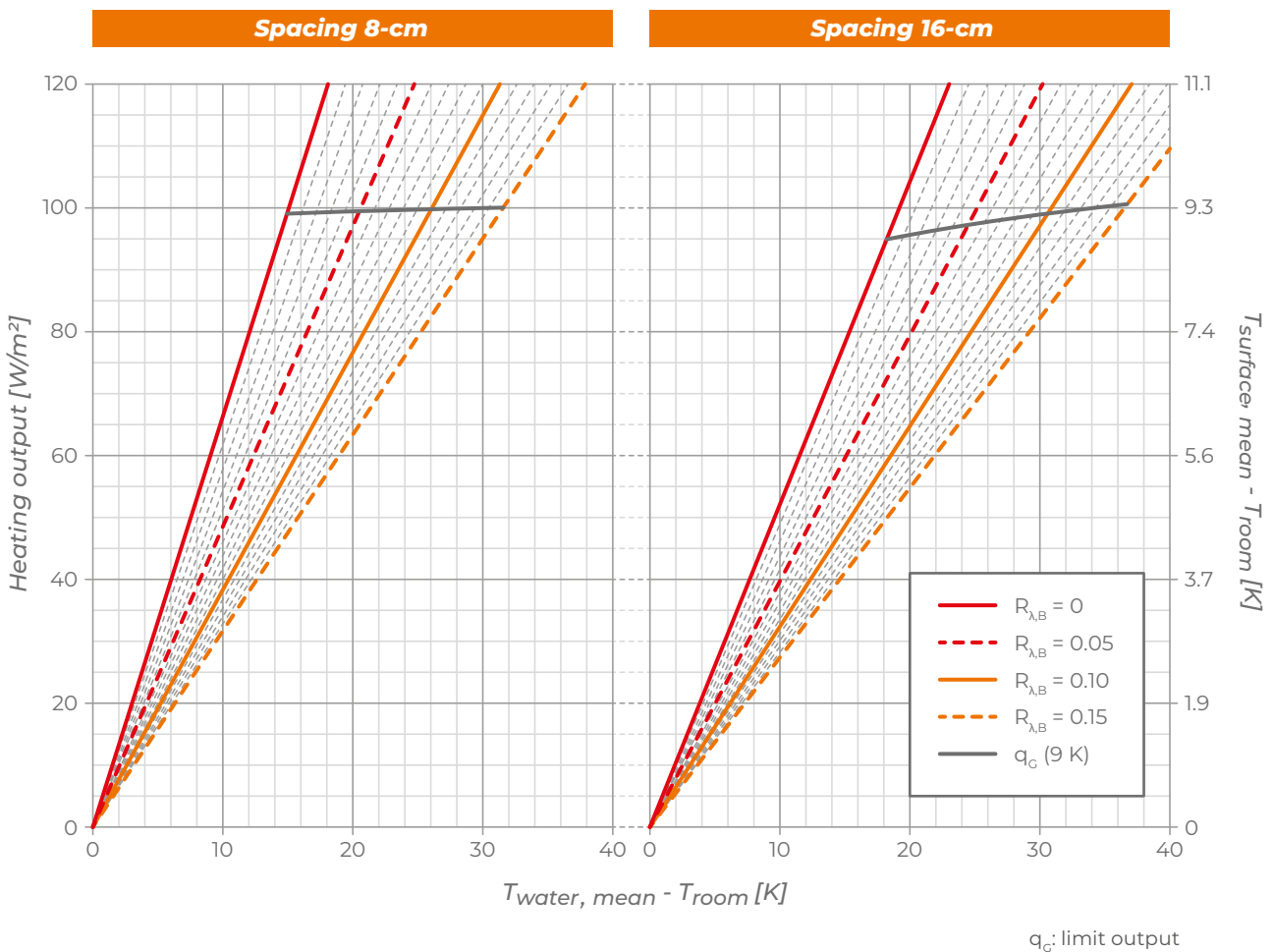

q_G : limit output

Thermal output in cooling

Input data			
Screed coverings above the pipe	s_U	0.045	m
Heat conductivity of screed	λ_E	1.2	W(m·k)
Piper external diameter	d_o	0.017	m
Pipe wall thickness	s_R	0.002	m
Pipe heat conductivity	λ_R	0.35	W(m·k)

K_H [m ² ·k]																
$R_{\lambda,B}$ [m ² ·k/W]																
T cm	0.00	0.01	0.02	0.03	0.04	0.05	0.06	0.07	0.08	0.09	0.10	0.11	0.12	0.13	0.14	0.15
8.3	4.672	4.444	4.237	4.049	3.877	3.718	3.573	3.438	3.313	3.197	3.088	2.987	2.892	2.803	2.720	2.641
16.6	3.876	3.709	3.557	3.416	3.286	3.165	3.054	2.949	2.852	2.761	2.675	2.595	2.519	2.448	2.380	2.316
24.9	3.221	3.101	2.989	2.885	2.788	2.698	2.613	2.533	2.458	2.387	2.321	2.258	2.198	2.141	2.087	2.036

$R_{\lambda,B}$: Heat conduction resistance of the floor covering
 T: Pipe spacing
 K_H : Equivalent thermal transmission coefficient

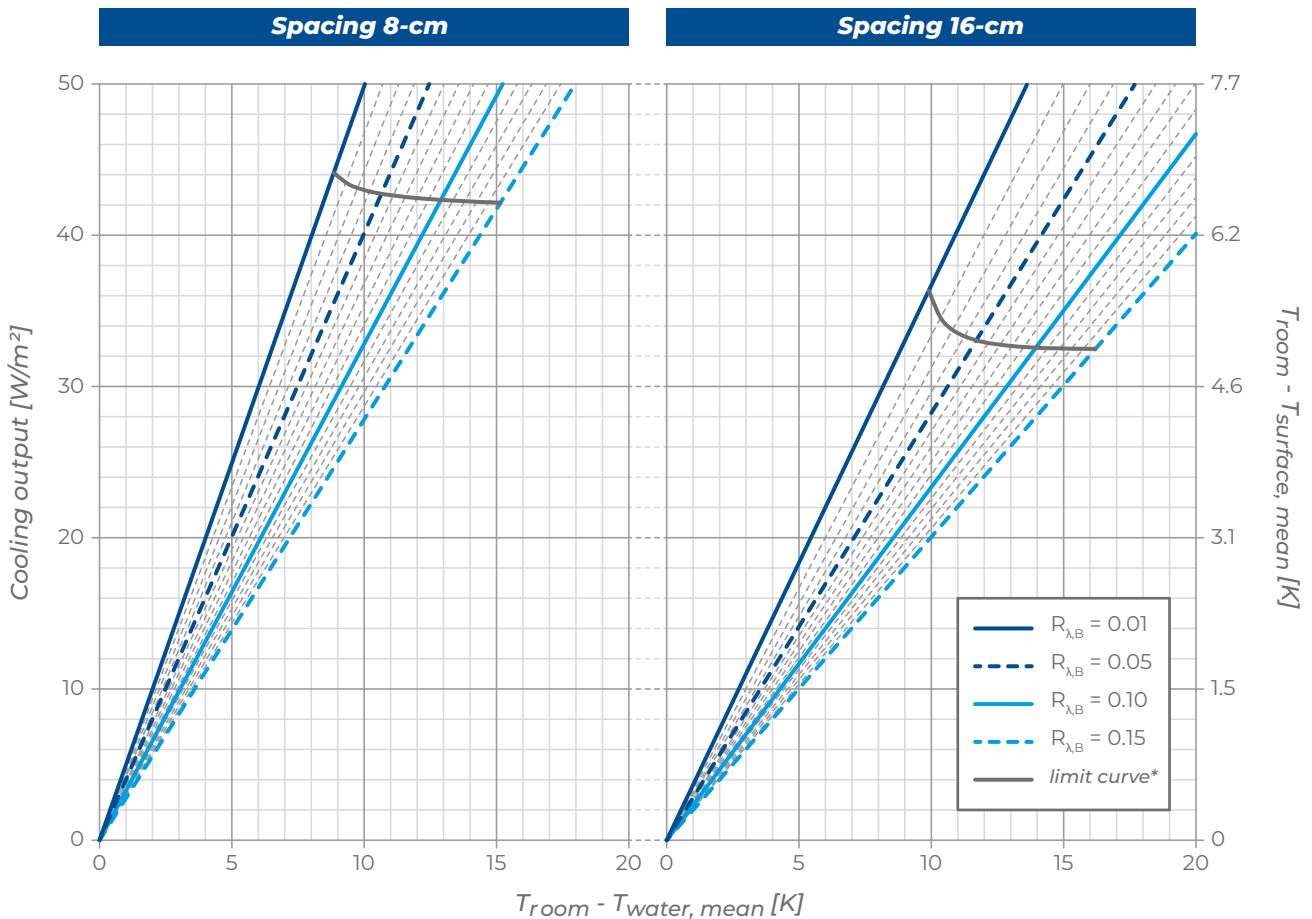

*valid only for room temperature = 26 °C



T50 is a traditional underfloor heating and cooling system, characterised by pipe anchored to the insulated base and embedded in the screed.

The central element of the system is the T50 studded panel made of waterproof moulded expanded polystyrene, produced according to UNI EN 13163, coated superficially with a special plastic film. The presence of tongue on the panel perimeter allows the optimal coupling and guarantee an easy and precise installation.

Thanks to the wide range of available thicknesses (20, 30, 40 and 46 mm), T50 system is able to satisfy several needs in terms of thermal insulation.

The system is completed by RDZ Tech PE-X Ø17 mm and Ø16 mm pipe, made of high-density polyethylene, cross-linked and provided with anti-oxygen barrier according to DIN 4726, the hooked clips, the open support elbows, the manifold, the Easy 15 perimeter belt and the 4S thermo-fluidifying additive.

FEATURES

- Panel in waterproof moulded expanded polystyrene
- RDZ Tech pipe Ø17 mm
- Available in thicknesses 20-30-40-46 mm
- Suitable for residential and commercial applications
- Easy and quick installation



SECTION AND DIMENSIONS

- 1 Skirting board
- 2 Flooring
- 3 Concrete
- 4 RDZ Tech pipe Ø 17-13
- 5 Perimeter belt
- 6 Substrate + levelling
- 7 T50 panel
- 8 Anti-shrinkage mesh

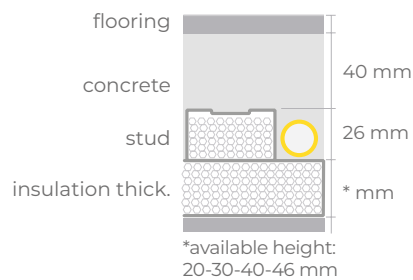
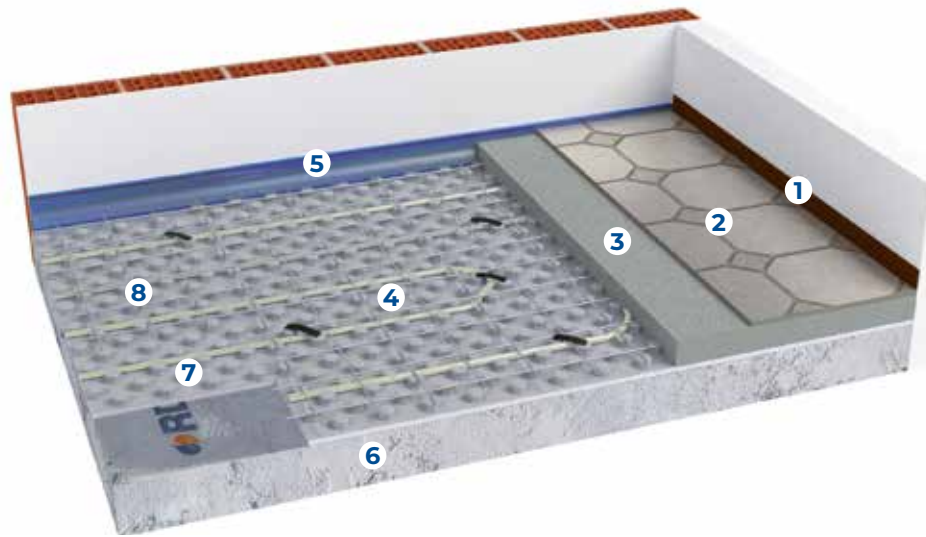

Indicative quotas

Panel thickness	20 mm	30 mm	40 mm	46 mm
Quote with Tiles - Parquet flooring	9.6 - 10.6 cm	10.6 - 11.6 cm	11.6 - 12.6 cm	12.2 - 13.2 cm
Quote with Marble - Blockboard flooring	10.6 - 12.6 cm	11.6 - 13.6 cm	12.6 - 14.6 cm	13.2 - 15.2 cm

Installation notes

- If the floor is in direct contact with the ground (i.e. without a sanitary void or insulating sheathing), provide a polyethylene sheet to act as a moisture barrier.
- Check that the site is clear and clean
- Check the dimensions available, taking into consideration the thickness of the insulation, screed and flooring chosen.
- Lay the perimeter belt and the insulation panels
- Lay the pipes as stated the project
- Usually, it's not necessary to bend the pipe with a bending radius of less than 12.5 cm, i.e. with a laying pitch of less than 25 cm
- Test the system and leave it under pressure until all subsequent works are completed
- If necessary, install the anti-shrinkage mesh

Note: Please refer to the installation manual for more information.

PRODUCTS THAT COMPOSE THE SYSTEM



T50 Panel

Insulating studded panel made of waterproof moulded expanded polystyrene (according to UNI EN 13163), with closed-cell structure, which has high compression strength. This panel is combined with a special plastic film in order to protect it from humidity and to improve its resistance to the deformation of the walking surface. Insulating thickness 20 mm, total thickness 46 mm, equivalent total thickness 26.8 mm. These panels have a tongue along the perimeter to connect them for proper combination. They have a moulded surface with studs of 26 mm, so that the pipes can be fitted into the tabs of the panel at spacing of 5 cm or multiples.

SIZE	THICKNESS	CODE
1200x700 mm	20 mm	1600120
1200x700 mm	30 mm	1600130
1200x700 mm	40 mm	1600140
1200x700 mm	46 mm	1600146

Features	Level - class	20	30	40	46	Unit
Necessary Length	L(3)	1200				mm
Necessary Width	W(3)	700				mm
Total Thickness	T(2)	46	56	66	72	mm
Insulation thickness		20	30	40	46	mm
Equivalent thickness		26.8	36.8	46.8	52.8	mm
Compressive stress at 10% deformation	CS(10)150	≥ 150				kPa
Thermal conductivity	λ_D	0.035				W/(m·K)
Thermal resistance	R_D	0.60	0.85	1.10	1.30	(m ² ·K)/W
Transmittance	U	1.25	0.95	0.70	0.65	W/(m ² ·K)
Water vapour resistance factor	μ (MU)	30 ÷ 70				
Water vapour transmission	δ	0.009 ÷ 0.020				mg/(Pa·h·m)
Long-term water absorption by total immersion	WL(T)5	≤ 5				%
Dimension stability 48 h / 70 °C	DS(70,-)1	1				%
Size stability 23 °C / 50% R.H.	DS(N)2	± 0.2				%
Bending Resistance	BS200	200				kPa
Reaction to fire class		E				Euroclass
Declarations according to UNI EN 13163 : 2013						
Unique identification code of the product-type: T2-L3-W3-S2-P5-BS200-CS(10)150-DS(70,-)1-WL(T)5-MU(30-70)						



RDZ Tech PE-Xa Pipe Ø 17 Interior Layer

RDZ Tech PE-Xa pipe Ø17-13 made of high-density cross-linked polyethylene with the oxygen barrier between the PE-X layer and an outer layer made of PE, which ensures further protection during installation in the building site. The layers are combined thanks to a special glue.

TYPE	ROLL	CODE
PE-Xa	240 m	1013840
PE-Xa	600 m	1013850



RDZ Tech PE-Xa Pipe Ø 16

RDZ Tech Pipe PE-Xa Ø 16 is a crosslinked polyethylene pipe manufactured using the Organic Peroxide method, with EVOH oxygen barrier (5 layers) that prevents the permeability of the tube to oxygen diffusion, eliminating the problem of oxygen supply to the water flow and corrosion in the metal elements of the installation extending its lifetime. Diameter 16 mm - Thickness 2 mm.

TYPE	ROLL	CODE
PE-Xa	240 m	1013860
PE-Xa	600 m	1013870

Note: for further technical data see page 174



RDZ Easy PE-RT Pipe 5L Ø 17-13

RDZ EASY 5-layer PE-RT (non-crosslinked Polyethylene of Raised Temperature) provided with EVOH anti-oxygen according to DIN 4726, it is suitable for underfloor heating and cooling systems. Diameter 17 mm, Thickness 2 mm, Natural color.

TYPE	ROLL	CODE
PE-RT	600 m	1014756



RDZ Multilayer Easy PE-RT pipe Ø 16-12

PE-RT Type II/Al/PE-RT Type II multilayer pipe Ø 16x2 mm according to UNI EN ISO 21003. SKZ certified.

TYPE	ROLL	CODE
PE-RT/ALL/PE-RT	200 m	1020016



Easy 15 perimeter belt

Is the edge insulation, which absorbs floor expansions and acts as thermo-acoustic insulation for the walls. It is made of expanded polyethylene, and it is provided with an adhesive strip on one side, while on the other side it has a special polyethylene combined sheet in order to avoid infiltrations of mortar between belt and panel. This belt has small cuts on the backside to adjust its height.

SIZE	CODE
5x150 mm	1072150



Hooked clip

Hooked clips made of plastic material to ensure secure positioning of the pipe on the insulating panels.

PACKAGE	CODE
100 pieces	1017000



Open Elbow

Open elbow Ø 17 made of plastic material. It is used to support the pipes near the manifolds vertically and to protect them from any damage.

SIZE	CODE
Ø 17 mm	1130517



Thermofluidifying Additive 4S

Superflusing, multidosage, water reducing admixture for concrete to increase its workability and to improve its mechanical properties and thermal conductivity. It is a product which conforms to EN 934-2; T3.1 - 3.2.

SIZE	CODE
10 liters	1091911
20 liters	1091921

Tips for material calculation

Needed products	Requirements
T50 Panel	Area to be covered +3%
RDZ Tech pipe Ø 17 mm	Depending on the average pitch. Total = surface area / pitch [m ² /m]
Easy perimeter belt	1 metre per m ²
Open elbow Ø 17	2 for each circuit
Hooked clip	5 for each circuit
Thermofluidifying Additive 4S	Approx. 0.2 litres per m ²

Optional products	Requirements
Fibreglass Mesh	Area to be covered +10%
RDZ Fiber (polypropylene fibres)	1 kg per 16 m ²
Clip 75	To be used only if anti-shrinkage mesh is used. 5 clips/m ²
Humidity Barrier Sheet	Surface to be covered +20%
Inibitor XR20	2% of ENTIRE water content
Biocida XR40	1% of ENTIRE water content

Manifolds, heads, accessories and optional products (from page 160).

Note: The requirements in the table are indicative. Please refer to the construction project for confirmation.

THERMAL OUTPUT OF THE SYSTEM

Thermal output in heating

Input data			
Screed coverings above the pipe	s_U	0.045	m
Heat conductivity of screed	λ_E	1.2	W(m·k)
Piper external diameter	d_o	0.017	m
Pipe wall thickness	s_R	0.002	m
Pipe heat conductivity	λ_R	0.35	W(m·k)

K_H [$m^2 \cdot k$]																
$R_{\lambda,B}$ [$m^2 \cdot k/W$]																
T cm	0	0.01	0.02	0.03	0.04	0.05	0.06	0.07	0.08	0.09	0.10	0.11	0.12	0.13	0.14	0.15
10	6,288	5,867	5,502	5,182	4,898	4,645	4,416	4,209	4,021	3,850	3,694	3,549	3,416	3,292	3,178	3,072
15	5,433	5,095	4,801	4,544	4,316	4,114	3,926	3,757	3,603	3,464	3,337	3,214	3,102	2,998	2,902	2,813
20	4,713	4,439	4,203	3,996	3,814	3,652	3,497	3,359	3,233	3,120	3,016	2,913	2,818	2,731	2,650	2,575

$R_{\lambda,B}$: Heat conduction resistance of the floor covering
 T: Pipe spacing
 K_H : Equivalent thermal transmission coefficient

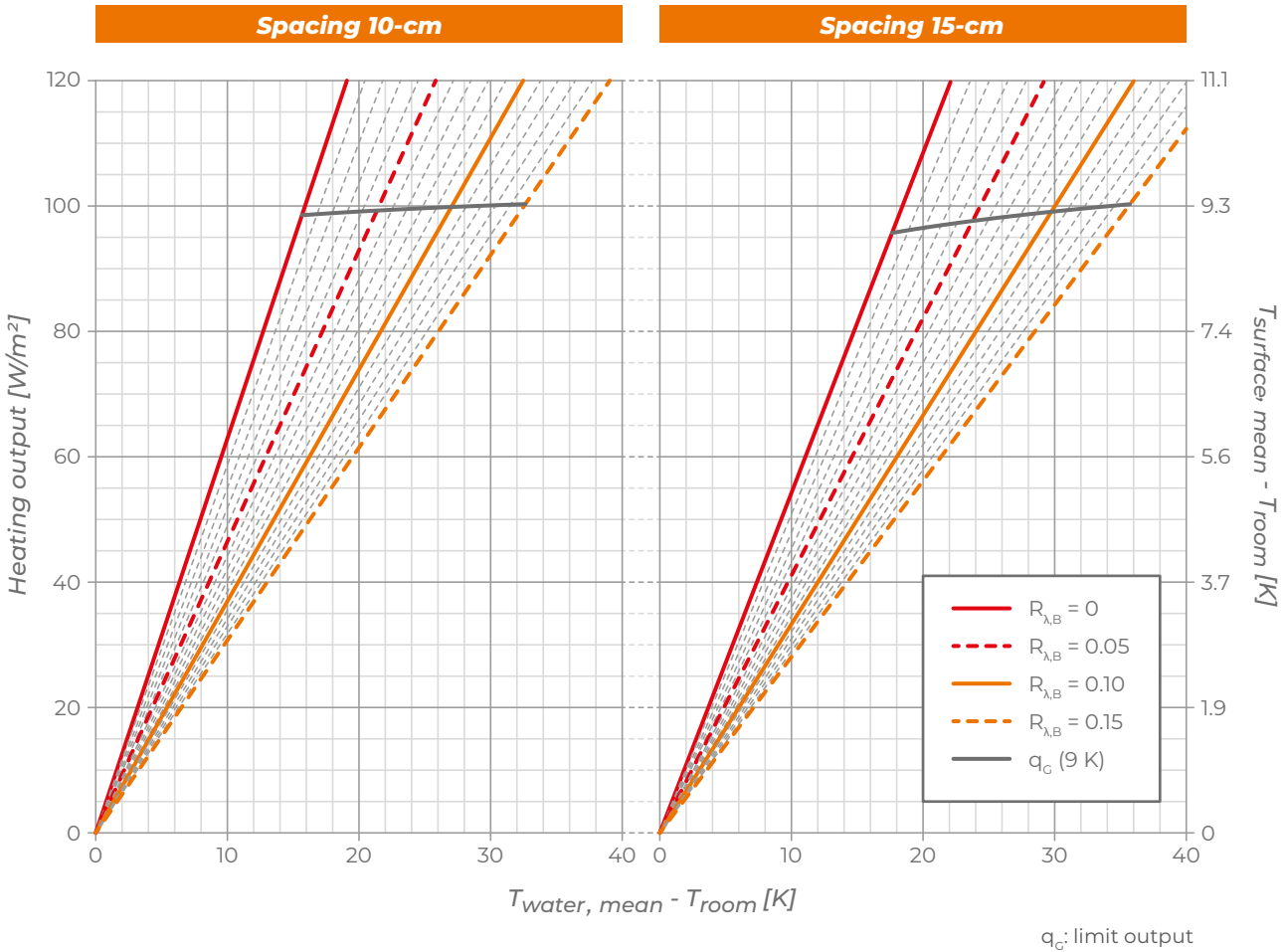

Thermal output in cooling

Input data			
Screed coverings above the pipe	s_U	0.045	m
Heat conductivity of screed	λ_E	1.2	W(m·k)
Piper external diameter	d_o	0.017	m
Pipe wall thickness	s_R	0.002	m
Pipe heat conductivity	λ_R	0.35	W(m·k)

K_H [m ² ·k]																
$R_{\lambda,B}$ [m ² ·k/W]																
T cm	0	0.01	0.02	0.03	0.04	0.05	0.06	0.07	0.08	0.09	0.10	0.11	0.12	0.13	0.14	0.15
10	4,405	4,200	4,013	3,841	3,684	3,540	3,406	3,282	3,166	3,059	2,959	2,864	2,776	2,693	2,615	2,541
15	3,936	3,766	3,611	3,468	3,335	3,213	3,099	2,993	2,894	2,801	2,714	2,633	2,556	2,483	2,415	2,350
20	3,520	3,380	3,251	3,131	3,020	2,917	2,820	2,730	2,645	2,565	2,490	2,420	2,353	2,289	2,230	2,173

$R_{\lambda,B}$: Heat conduction resistance of the floor covering
 T: Pipe spacing
 K_H : Equivalent thermal transmission coefficient

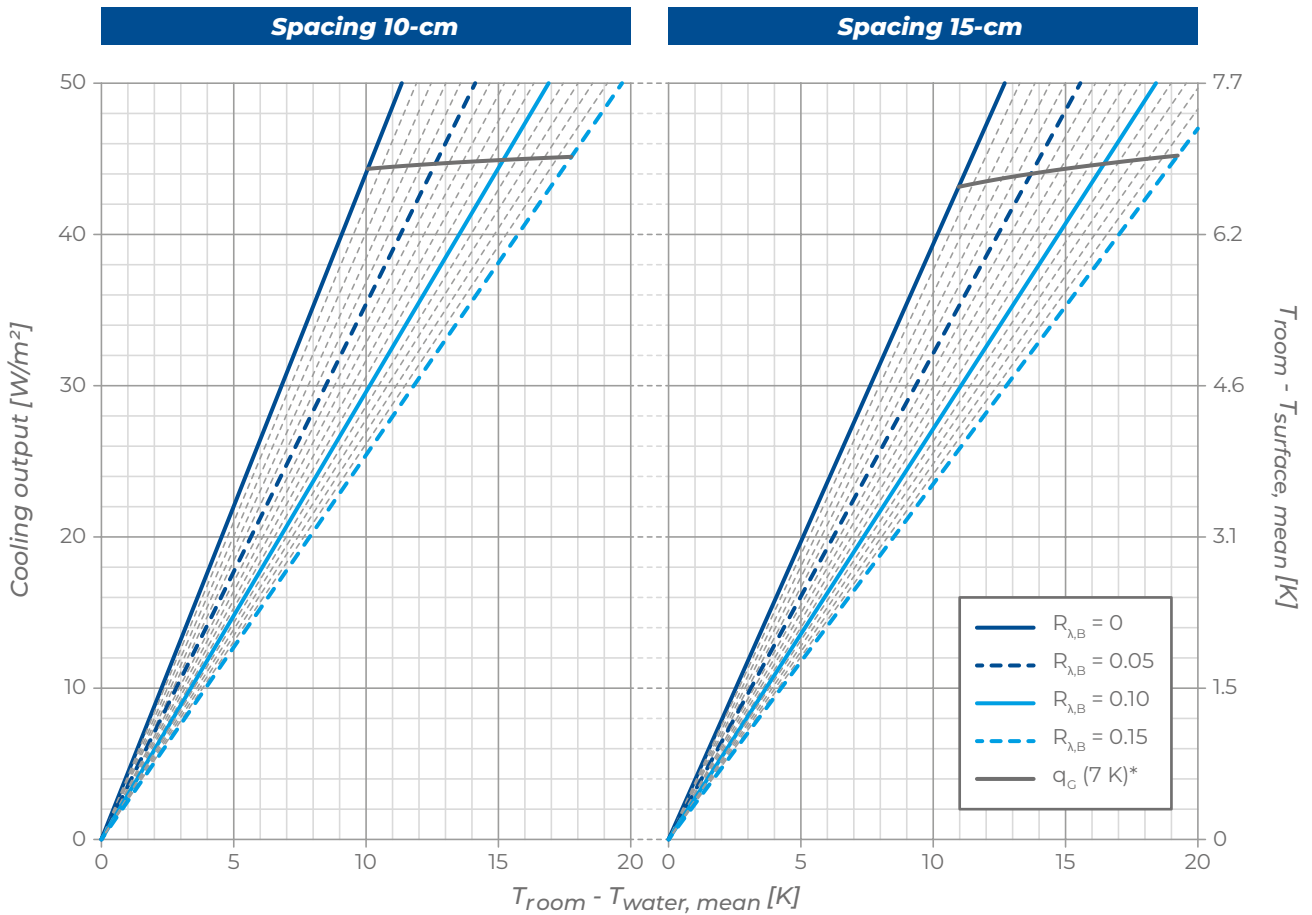

*valid only for room temperature = 26 °C



TF HP is a traditional underfloor heating and cooling system, characterised by pipe anchored to the insulated base and embedded in the screed.

The central element of the system is the thermoformed TF HP panel, made of sintered expanded polystyrene, produced in conformity to UNI EN 13163. The surface coating is made with a HIPS thermoformed film, that give to the panel a higher resistance to deformation of the walking surface during installation and the presence of tongue along its perimeter allow the optimal coupling between the panels.

Thanks to the wide range of available thicknesses (10, 20, 33 and 40 mm), TF HP system is able to satisfy several needs in terms of thermal insulation.

The system is completed by RDZ Tech PE-X Ø17 mm and Ø16 mm pipe, made of high-density polyethylene, cross-linked and provided with anti-oxygen barrier according to DIN 4726, the hooked clips, the open support elbows, the manifold, the Easy 15 perimeter belt and the 4S thermo-fluidifying additive.

FEATURES

- Expanded polystyrene panel with graphite and HIPS thermoformed film
- Thermal insulation with reduced thickness
- Available in thicknesses 10-20-33-40 mm
- Suitable for residential and commercial applications
- Easy and quick installation



SECTION AND DIMENSIONS

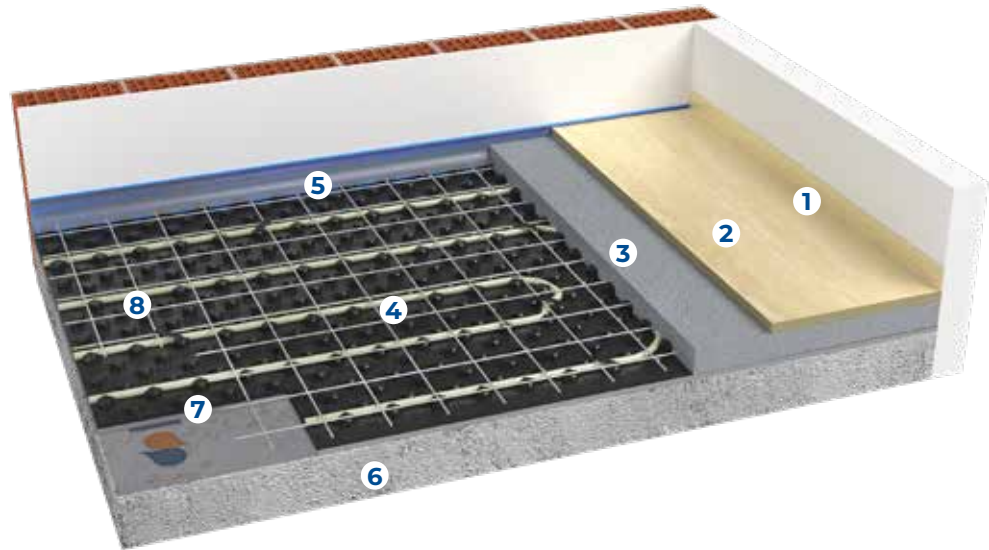

- 1 Skirting board
- 2 Flooring
- 3 Concrete
- 4 RDZ Tech pipe Ø 17-13
- 5 Perimeter belt
- 6 Substrate + levelling
- 7 TF HP panel
- 8 Anti-shrinkage mesh

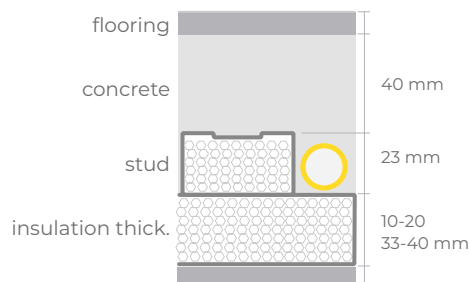

Indicative quotas

Panel thickness	10 mm	20 mm	33 mm	40 mm
Quote with Tiles - Parquet flooring	8.3 - 9.3 cm	9.3 - 10.3 cm	10.6 - 11.6 cm	11.3 - 12.3 cm
Quote with Marble - Blockboard flooring	9.3 - 11.3 cm	10.3 - 11.3 cm	11.6 - 13.6 cm	12.3 - 14.3 cm

Installation notes

- If the floor is in direct contact with the ground (i.e. without a sanitary void or insulating sheathing), provide a polyethylene sheet to act as a moisture barrier.
- Check that the site is clear and clean
- Check the dimensions available, taking into consideration the thickness of the insulation, screed and flooring chosen.
- Lay the perimeter belt and the insulation panels
- Lay the pipes as stated the project
- Usually, it's not necessary to bend the pipe with a bending radius of less than 12.5 cm, i.e. with a laying pitch of less than 25 cm
- Test the system and leave it under pressure until all subsequent works are completed
- If necessary, install the anti-shrinkage mesh

Note: Please refer to the installation manual for more information.

PRODUCTS THAT COMPOSE THE SYSTEM



TF HP Panel

TF HP panel made of expanded sintered polystyrene with graphite, produced in conformity to UNI EN 13163, with closed-cell structure. It is combined with thermoformed film in HIPS, thickness 0.6 mm, in order to improve its resistance to the deformation of the walking surface according to EN 1264. Compressive strength according to UNI 826 is 150 kPa. These panels have a tongue along the perimeter to connect them for proper combination. The moulded surface with studs of 23 mm allows the pipe to be fitted into the tabs at spacing of 5 cm or multiples.

SIZE	THICKNESS	CODE
1400x800 mm	10 mm	1045710
1400x800 mm	20 mm	1045720
1400x800 mm	33 mm	1045733
1400x800 mm	40 mm	1045740

Properties	Symbol	Thickness				Unit	Standard
		10	20	33	40		
Necessary Length (±3 mm)	L3	1400				mm	UNI EN 13163:2012 + A1:2015
Necessary Width (±3 mm)	W3	800				mm	
Total Thickness (±2 mm)	T2	33	43	56	63	mm	
Insulation thickness (±2 mm)		10	20	33	40	mm	
Equivalent thickness		13.9	23.9	36.9	43.9	mm	
Weight		1350	1610	1950	2130	g	
Compressive resistance at 10% deformation	CS(10)150	σ10 ≥ 150 kPa				kPa	
Thermal conductivity at 10 °C	λ _p	0.030				W/(m·K)	
Thermal resistance	R _p	0.30	0.65	1.10	1.30	(m ² ·K)/W	
Water vapour resistance factor	μ (MU)	30 ÷ 70					
HIPS Water vapour resistance factor		10.000				mg/(Pa·h·m)	
Duration of the fire reaction against aging and/or degradation		Fire performance for EPS does not change as time goes by					
Duration of the thermal resistance against aging and/or degradation		EPS thermal conductivity does not change as time goes by					
Dimensional stability 23 °C / 50% U.R.		0.2				%	
Reaction to fire class		F				Euroclass	
Water absorption by total immersion	WL(T) 4	0,5				%	
Thickness for the thermoformed film in HIPS		600				μm	
Softening temperature		> 90				°C	
Decomposition temperature		> 300					
Auto-ignition temperature		> 400					
Maximum operating temperature		70					
Declarations according to UNI EN 13163:2012 + A1:2015							
CLASS: EPS 150	EPS-EN 13163-T2-L3-W3-S2-P5-CS(10)150-WL(P)0,5-MU(30-70)						



RDZ Tech PE-Xa Pipe Ø 17 Interior Layer

RDZ Tech PE-Xa pipe Ø 17-13 made of high-density cross-linked polyethylene with the oxygen barrier between the PE-X layer and an outer layer made of PE, which ensures further protection during installation in the building site. The layers are combined thanks to a special glue.

TYPE	ROLL	CODE
PE-Xa	240 m	1013840
PE-Xa	600 m	1013850

Note: for further technical data see page 178



RDZ Easy PE-RT Pipe 5L Ø 17-13

RDZ EASY 5-layer PE-RT (non-crosslinked Polyethylene of Raised Temperature) provided with EVOH anti-oxygen according to DIN 4726, it is suitable for underfloor heating and cooling systems. Diameter 17 mm, Thickness 2 mm, Natural color.

TYPE	ROLL	CODE
PE-RT	600 m	1014756



RDZ Multilayer Easy PE-RT pipe Ø 16-12

PE-RT Type II/Al/PE-RT Type II multilayer pipe Ø 16x2 mm according to UNI EN ISO 21003. SKZ certified.

TYPE	ROLL	CODE
PE-RT/ALL/PE-RT	200 m	1020016



Easy 15 perimeter belt

Is the edge insulation, which absorbs floor expansions and acts as thermo-acoustic insulation for the walls. It is made of expanded polyethylene, and it is provided with an adhesive strip on one side, while on the other side it has a special polyethylene combined sheet in order to avoid infiltrations of mortar between belt and panel. This belt has small cuts on the backside to adjust its height.

SIZE	CODE
5x150 mm	1072150



Hooked clip

Hooked clips made of plastic material to ensure secure positioning of the pipe on the insulating panels.

PACKAGE	CODE
100 pieces	1017000



Open Elbow

Open elbow Ø 17 made of plastic material. It is used to support the pipes near the manifolds vertically and to protect them from any damage.

SIZE	CODE
Ø 17 mm	1130517



Thermofluidifying Additive 4S

Superfluxing, multidosage, water reducing admixture for concrete to increase its workability and to improve its mechanical properties and thermal conductivity. It is a product which conforms to EN 934-2; T3.1 - 3.2.

SIZE	CODE
10 liters	1091911
20 liters	1091921

Tips for material calculation

Needed products	Requirements
TF HP Panel	Area to be covered +3%.
RDZ Tech pipe Ø 17 mm	Depending on the average pitch. Total = area / pitch [m ² /m].
Easy 15 perimeter belt	1 metre per m ²
Open elbow Ø 17	2 for each circuit
Hooked clip	5 for each circuit

Optional products	Requirements
Fibreglass Mesh	Area to be covered +10%
RDZ Fiber (polypropylene fibres)	1 kg per 16 m ²
Clip 75	To be used only if anti-shrinkage net is used. 5 clips/m ²
Humidity Barrier Sheet	Surface to be covered +20%
Thermofluidifying Additive 4S	Approx. 0.2 litres per m ²
Inibitor XR20	2% of ENTIRE water content
Biocida XR40	1% of ENTIRE water content

Manifolds, heads, accessories and optional products (from page 160).

Note: The requirements in the table are indicative. Please refer to the construction project for confirmation..

THERMAL OUTPUT OF THE SYSTEM

Thermal output in heating

Input data			
Screed coverings above the pipe	s_U	0.045	m
Heat conductivity of screed	λ_E	1.2	W(m·k)
Piper external diameter	d_o	0.017	m
Pipe wall thickness	s_R	0.002	m
Pipe heat conductivity	λ_R	0.35	W(m·k)

$K_H [m^2 \cdot k]$																
$R_{\lambda,B} [m^2 \cdot k/W]$																
T cm	0	0.01	0.02	0.03	0.04	0.05	0.06	0.07	0.08	0.09	0.10	0.11	0.12	0.13	0.14	0.15
8.1	6,331	5,905	5,535	5,211	4,924	4,669	4,437	4,228	4,038	3,866	3,708	3,562	3,428	3,304	3,189	3,082
12.2	5,471	5,128	4,830	4,569	4,339	4,135	3,945	3,774	3,619	3,478	3,350	3,226	3,113	3,008	2,912	2,822
16.3	4,745	4,468	4,228	4,018	3,834	3,670	3,514	3,374	3,247	3,132	3,028	2,924	2,828	2,740	2,659	2,583

$R_{\lambda,B}$: Heat conduction resistance of the floor covering
 T: Pipe spacing
 K_H : Equivalent thermal transmission coefficient

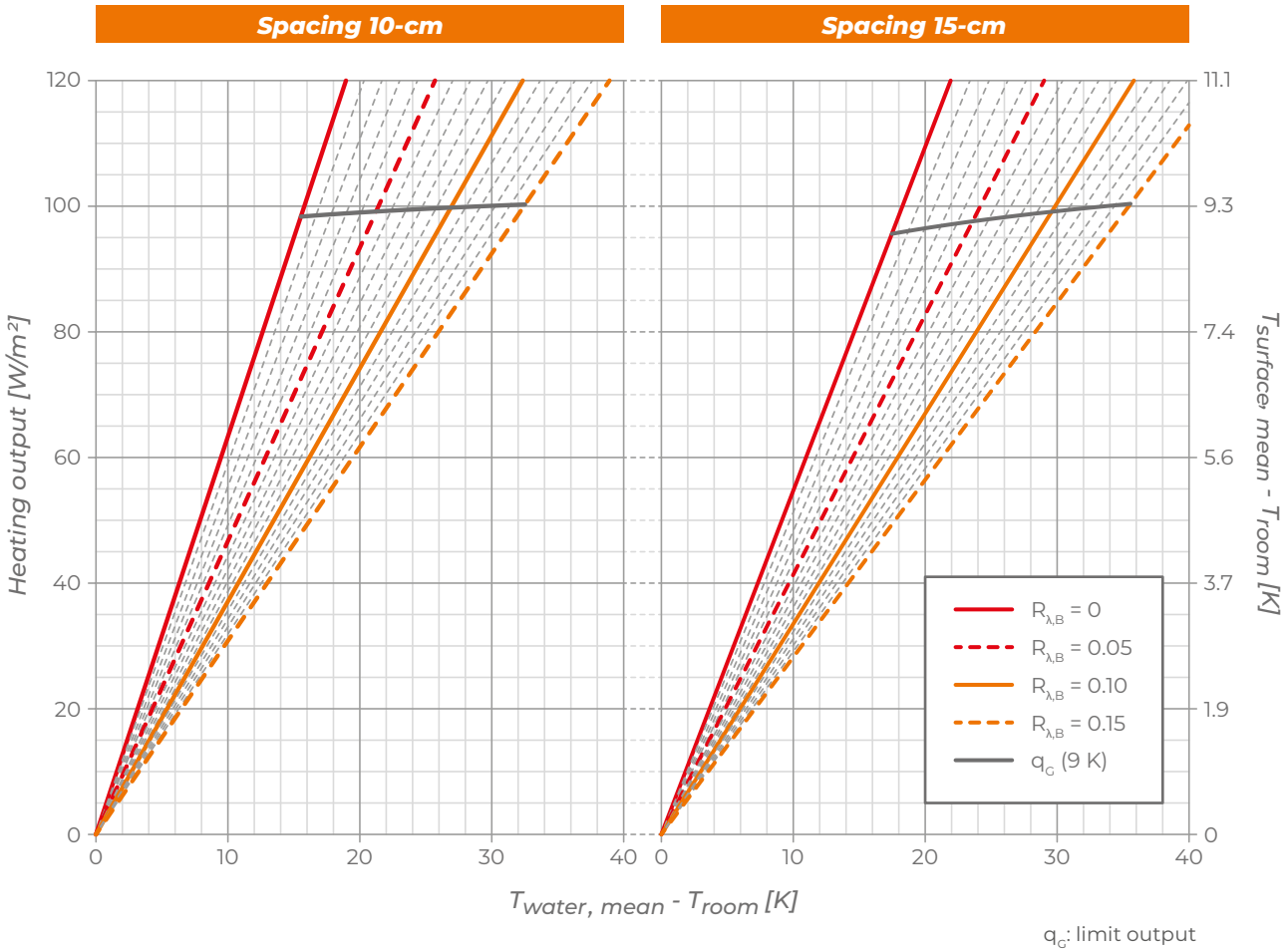

Thermal output in cooling

Input data			
Screed coverings above the pipe	s_U	0.045	m
Heat conductivity of screed	λ_E	1.2	W(m·k)
Piper external diameter	d_o	0.017	m
Pipe wall thickness	s_R	0.002	m
Pipe heat conductivity	λ_R	0.35	W(m·k)

K_H [m ² ·k]																
$R_{\lambda,B}$ [m ² ·k/W]																
T cm	0	0.01	0.02	0.03	0.04	0.05	0.06	0.07	0.08	0.09	0.10	0.11	0.12	0.13	0.14	0.15
8.1	4,426	4,218	4,030	3,857	3,699	3,553	3,418	3,293	3,177	3,069	2,968	2,873	2,784	2,701	2,622	2,548
12.2	3,955	3,783	3,627	3,482	3,349	3,225	3,110	3,003	2,904	2,810	2,723	2,641	2,563	2,490	2,421	2,356
16.3	3,537	3,395	3,265	3,144	3,032	2,928	2,831	2,739	2,654	2,574	2,498	2,427	2,359	2,296	2,235	2,178

$R_{\lambda,B}$: Heat conduction resistance of the floor covering
 T: Pipe spacing
 K_H : Equivalent thermal transmission coefficient

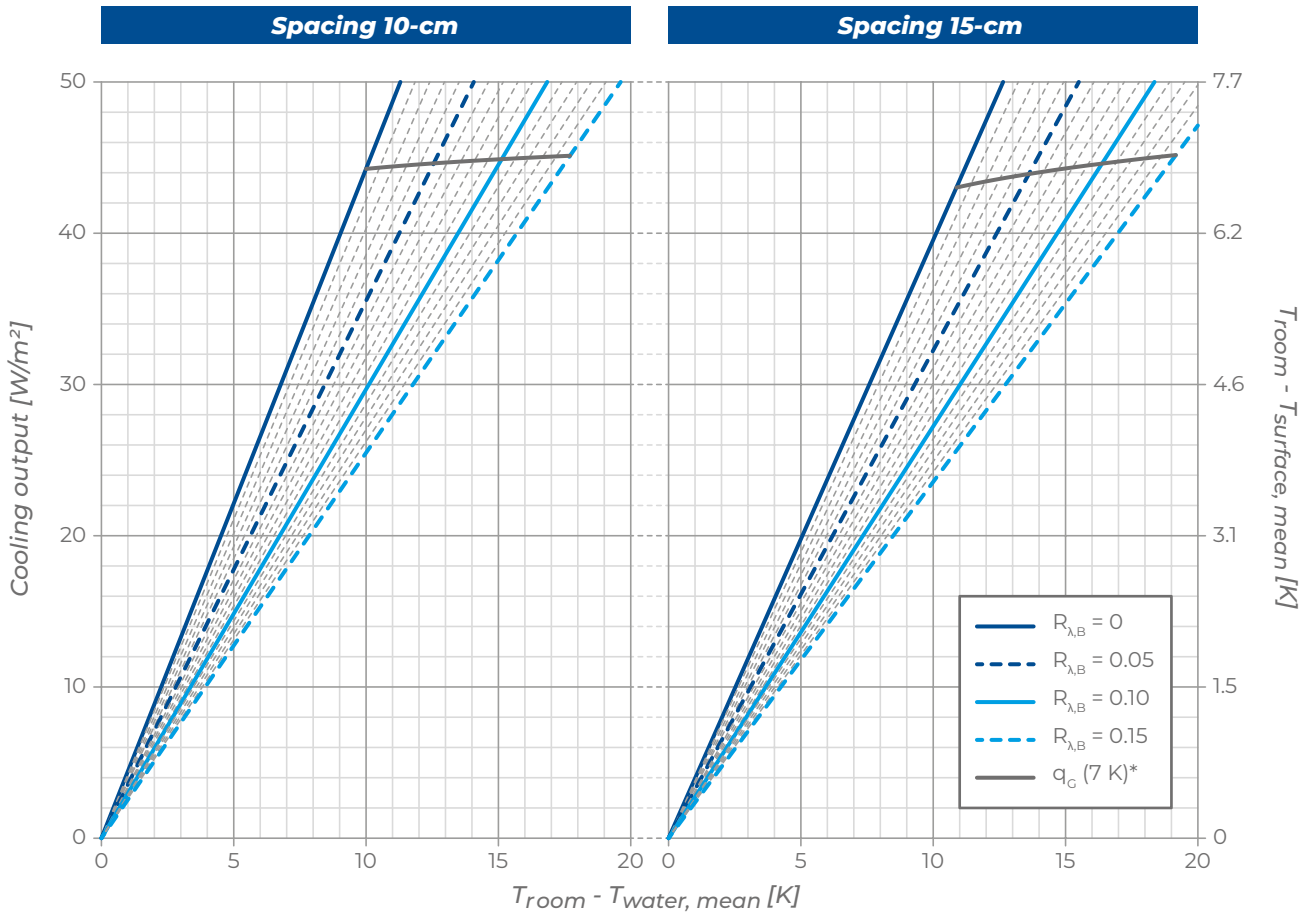

*valid only for room temperature = 26 °C



TF is a traditional underfloor heating and cooling system, characterized by pipe anchored to the insulated base and embedded in the screed.

The central element of the system is the studded panel made of waterproof expanded polystyrene, produced according to UNI EN 13163, it is characterized by a compressive strength of 150 kPa. The surface coating is made with a HIPS thermoformed film, that gives to the panel a higher resistance to deformation of the walking surface during installation and the presence of tongue along its perimeter allow the optimal coupling between the panels.

The system is completed by RDZ Tech PE-X Ø 17 mm and Ø 16 mm pipe, RDZ Easy PE-RT Ø 17 pipe or RDZ Multilayer Easy PE-RT Ø 16 pipe, the hooked clips, the open support elbows, the manifold, the Easy 15 perimeter belt and the 4S thermo-fluidifying additive.

FEATURES

- Expanded polystyrene panel with HIPS thermoformed film
- RDZ Tech PE-X Ø17 mm and Ø 16 mm pipe, Easy PE-RT Ø 17 pipe or Multilayer
- Easy PE-RT Ø 16 pipe
- Available in thicknesses 10-20-30-40 mm
- Suitable for residential and commercial applications
- Easy and quick installation



SECTION AND DIMENSIONS

- 1 Skirting board
- 2 Flooring
- 3 Concrete
- 4 RDZ Tech pipe Ø 17-13
- 5 Perimeter belt
- 6 Substrate + levelling
- 7 TF panel
- 8 Anti-shrinkage mesh

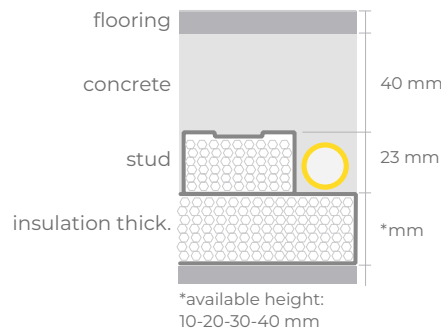
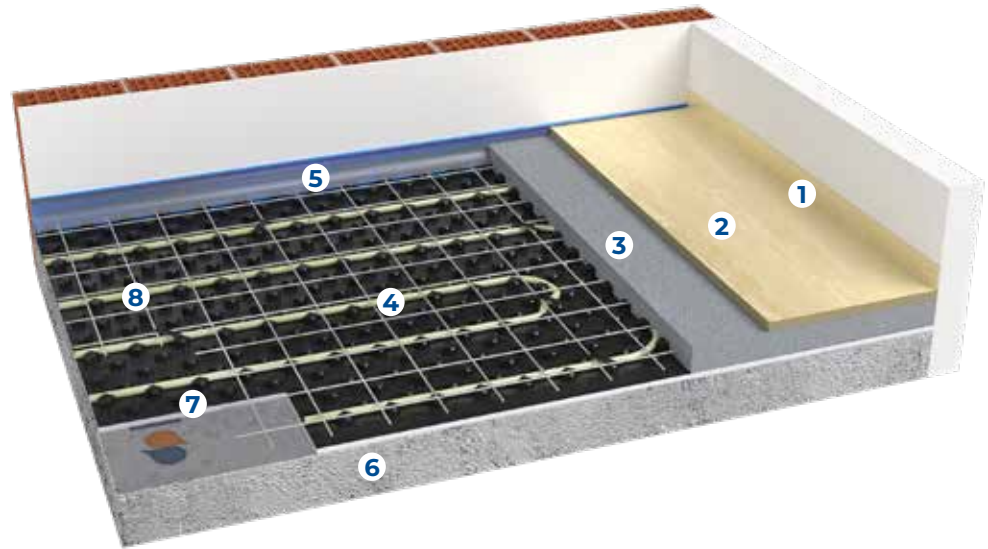

Indicative quotas

Panel thickness	10 mm	20 mm	30 mm	40 mm
Quote with Tiles - Parquet flooring	8.3 - 9.3 cm	9.3 - 10.3 cm	10.3 - 11.3 cm	11.3 - 12.3 cm
Quote with Marble - Blockboard flooring	9.3 - 11.3 cm	10.3 - 11.3 cm	11.3 - 13.3 cm	12.3 - 14.3 cm

Installation notes

- If the floor is in direct contact with the ground (i.e. without a sanitary void or insulating sheathing), provide a polyethylene sheet to act as a moisture barrier.
- Check that the site is clear and clean
- Check the dimensions available, taking into consideration the thickness of the insulation, screed and flooring chosen.
- Lay the perimeter belt and the insulation panels
- Lay the pipes as stated the project
- Usually, it's not necessary to bend the pipe with a bending radius of less than 12.5 cm, i.e. with a laying pitch of less than 25 cm
- Test the system and leave it under pressure until all subsequent works are completed
- If necessary, install the anti-shrinkage mesh

Note: Please refer to the installation manual for more information.

PRODUCTS THAT COMPOSE THE SYSTEM



TF Panel

Insulating panel with studs made of aintered expanded polystyrene, produced in conformity with UNI EN 13163, with closed-cell structure. This panel is combined with a HIPS thermoformed film, thickness 0.6 mm, in order to improve its resistance to the deformation of the walking surface in compliance with EN 1264. Insulating thickness 10 mm, total thickness 33 mm, equivalent total thickness 13.9 mm, thermal resistance 0.40 (m²·K)/W according to UNI EN 13163. Compressive strength according to EN 826 is 150 kPa. These panels have a tongue along the perimeter to connect them for proper combination. They have a moulded surface with studs of 23 mm so that the pipe mm can be fitted into the tabs of the panel at spacing of 5 cm or multiples.

SIZE	THICKNESS	CODE
1400x800 mm	10 mm	1045210
1400x800 mm	20 mm	1045220
1400x800 mm	30 mm	1045230
1400x800 mm	40 mm	1045240

Features	Level - class	10	20	30	40	Unit
Necessary Length	L(3)	1400				mm
Necessary Width	W(3)	800				mm
Total Thickness	T(2)	33	43	53	63	mm
Insulation thickness		10	20	30	40	mm
Equivalent thickness		13.9	23.9	33.9	43.9	mm
Compressive stress at 10% deformation	CS(10)150	σ ₁₀ ≥ 150				kPa
Thermal conductivity	λ _b	0.034				W/(m·K)
Thermal resistance	R _b	0.25	0.55	0.85	1.15	(m ² ·K)/W
Water vapour resistance factor	μ (MU)	30 ÷70				
Duration of the fire reaction against aging and/or degradation	Fire performance for EPS does not change as time goes by					
Duration of the thermal resistance against aging and-or degradation	Fire performance for EPS does not change as time goes by					
Dimension stability 48 h / 70 °C		< 1				%
Reaction to fire class		F				Euroclass
Water absorption by partial immersion	WL(P) 0.5	≤ 0.5				Kg/m ²
Softening temperature		> 70				°C
Declarations according to UNI EN 13163:2015						
CLASS: EPS 150 EPS-UNI EN 13163:2015-T2-L3-W3-S2-P5-CS(10)150-WL(P)0.5-MU(30÷70)						



RDZ Tech PE-Xa Pipe Ø 17 Interior Layer

RDZ Tech PE-Xa pipe Ø 17-13 made of high-density cross-linked polyethylene with the oxygen barrier between the PE-X layer and an outer layer made of PE, which ensures further protection during installation in the building site. The layers are combined thanks to a special glue.

TYPE	ROLL	CODE
PE-Xa	240 m	1013840
PE-Xa	600 m	1013850



RDZ Tech PE-Xa Pipe Ø 16

RDZ Tech Pipe PE-Xa Ø 16 is a crosslinked polyethylene pipe manufactured using the Organic Peroxide method, with EVOH oxygen barrier (5 layers) that prevents the permeability of the tube to oxygen diffusion, eliminating the problem of oxygen supply to the water flow and corrosion in the metal elements of the installation extending its lifetime. Diameter 16 mm - Thickness 2 mm.

TYPE	ROLL	CODE
PE-Xa	240 m	1013860
PE-Xa	600 m	1013870

Note: for further technical data see page 174

TRADITIONAL FLOOR SYSTEMS



RDZ Easy PE-RT Pipe 5L Ø 17-13

RDZ EASY 5-layer PE-RT (non-crosslinked Polyethylene of Raised Temperature) provided with EVOH anti-oxygen according to DIN 4726, it is suitable for underfloor heating and cooling systems. Diameter 17 mm, Thickness 2 mm, Natural color.

TYPE	ROLL	CODE
PE-RT	600 m	1014756



RDZ Multilayer Easy PE-RT pipe Ø 16-12

PE-RT Type II/Al/PE-RT Type II multilayer pipe Ø 16x2 mm according to UNI EN ISO 21003. SKZ certified.

TYPE	ROLL	CODE
PE-RT/ALL/PE-RT	200 m	1020016



Easy 15 perimeter belt

Is the edge insulation, which absorbs floor expansions and acts as thermo-acoustic insulation for the walls. It is made of expanded polyethylene, and it is provided with an adhesive strip on one side, while on the other side it has a special polyethylene combined sheet in order to avoid infiltrations of mortar between belt and panel. This belt has small cuts on the backside to adjust its height.

SIZE	CODE
5x150 mm	1072150



Hooked clip

Hooked clips made of plastic material to ensure secure positioning of the pipe on the insulating panels.

PACKAGE	CODE
100 pieces	1017000



Open Elbow

Open elbow Ø 17 made of plastic material. It is used to support the pipes near the manifolds vertically and to protect them from any damage.

SIZE	CODE
Ø 17 mm	1130517



Thermofluidifying Additive 4S

Superfluxing, multidosage, water reducing admixture for concrete to increase its workability and to improve its mechanical properties and thermal conductivity. It is a product which conforms to EN 934-2; T3.1 - 3.2.

SIZE	CODE
10 liters	1091911
20 liters	1091921

Tips for material calculation

Needed products	Requirements
TF Panel	Area to be covered +3%
RDZ Tech pipe Ø17	Depending on the average pitch. Total = surface area / pitch [m ² /m]
Easy perimeter belt	1 metre per m ²
Open elbow Ø 17	2 for each circuit
Hooked clip	5 for each circuit
Thermofluidifying Additive 4S	Approx. 0.2 litres per m ²

Optional products	Requirements
Fibreglass Mesh	Area to be covered +10%
RDZ Fiber (polypropylene fibres)	1 kg per 16 m ²
Clip 75	To be used only if anti-shrinkage mesh is used. 5 clips/m ²
Humidity Barrier Sheet	Surface to be covered +20%
Inibitor XR20	2% of ENTIRE water content
Biocida XR40	1% of ENTIRE water content

Manifolds, heads, accessories and optional products (from page 160).

Note: The requirements in the table are indicative. Please refer to the construction project for confirmation.

THERMAL OUTPUT OF THE SYSTEM

Thermal output in heating

Input data			
Screed coverings above the pipe	s_U	0.045	m
Heat conductivity of screed	λ_E	1.2	W(m·k)
Piper external diameter	d_a	0.017	m
Pipe wall thickness	s_R	0.002	m
Pipe heat conductivity	λ_R	0.35	W(m·k)

K_H [m ² ·k]																
$R_{\lambda,B}$ [m ² ·k/W]																
T cm	0	0.01	0.02	0.03	0.04	0.05	0.06	0.07	0.08	0.09	0.10	0.11	0.12	0.13	0.14	0.15
8.1	6,331	5,905	5,535	5,211	4,924	4,669	4,437	4,228	4,038	3,866	3,708	3,562	3,428	3,304	3,189	3,082
12.2	5,471	5,128	4,830	4,569	4,339	4,135	3,945	3,774	3,619	3,478	3,350	3,226	3,113	3,008	2,912	2,822
16.3	4,745	4,468	4,228	4,018	3,834	3,670	3,514	3,374	3,247	3,132	3,028	2,924	2,828	2,740	2,659	2,583

$R_{\lambda,B}$: Heat conduction resistance of the floor covering
 T: Pipe spacing
 K_H : Equivalent thermal transmission coefficient

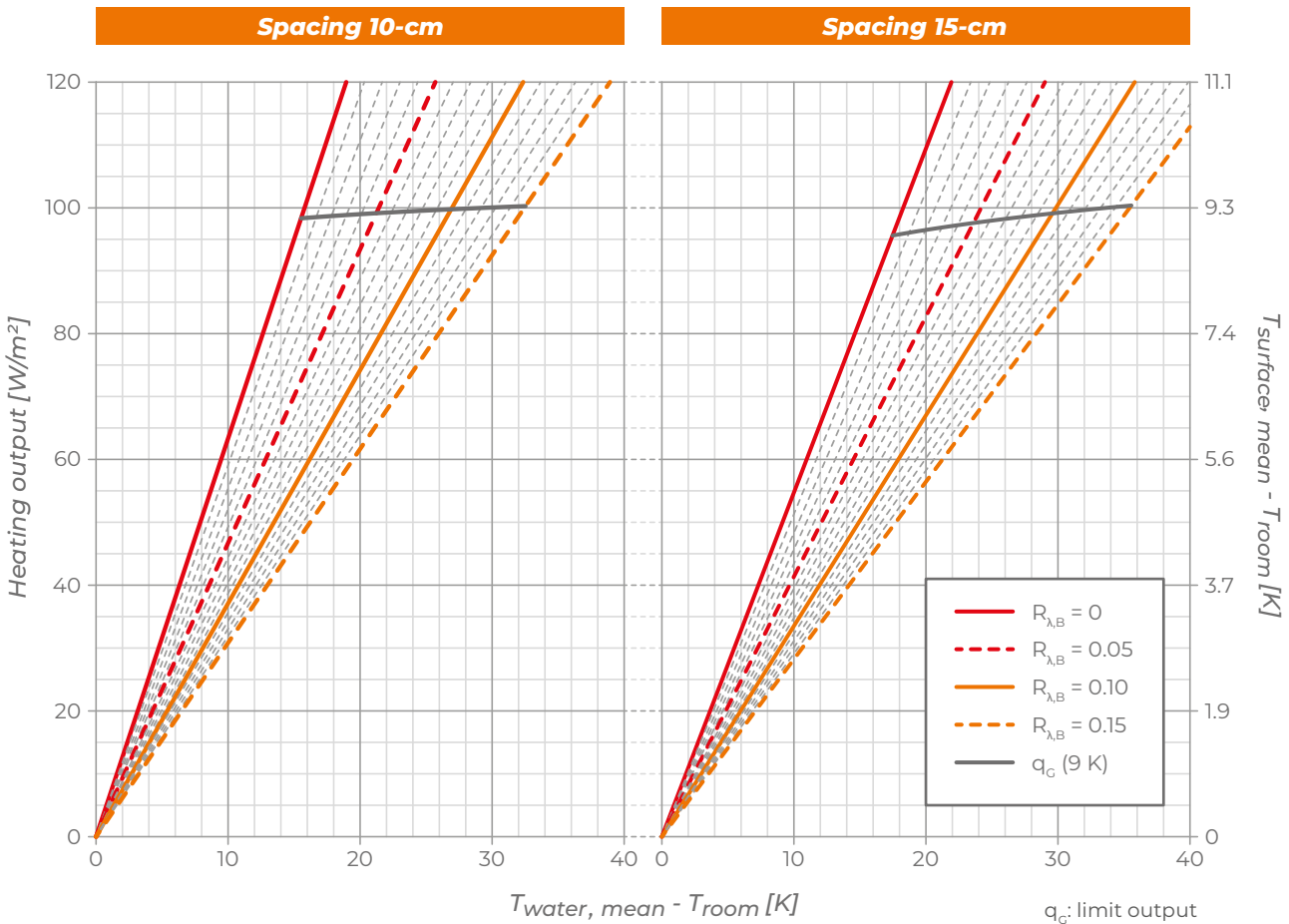

Thermal output in cooling

Input data			
Screed coverings above the pipe	s_U	0.045	m
Heat conductivity of screed	λ_E	1.2	W(m·k)
Piper external diameter	d_a	0.017	m
Pipe wall thickness	s_R	0.002	m
Pipe heat conductivity	λ_R	0.35	W(m·k)

K_H [m ² ·k]																
$R_{\lambda,B}$ [m ² ·k/W]																
T cm	0	0.01	0.02	0.03	0.04	0.05	0.06	0.07	0.08	0.09	0.10	0.11	0.12	0.13	0.14	0.15
8.1	4,426	4,218	4,030	3,857	3,699	3,553	3,418	3,293	3,177	3,069	2,968	2,873	2,784	2,701	2,622	2,548
12.2	3,955	3,783	3,627	3,482	3,349	3,225	3,110	3,003	2,904	2,810	2,723	2,641	2,563	2,490	2,421	2,356
16.3	3,537	3,395	3,265	3,144	3,032	2,928	2,831	2,739	2,654	2,574	2,498	2,427	2,359	2,296	2,235	2,178

$R_{\lambda,B}$: Heat conduction resistance of the floor covering
 T: Pipe spacing
 K_H : Equivalent thermal transmission coefficient

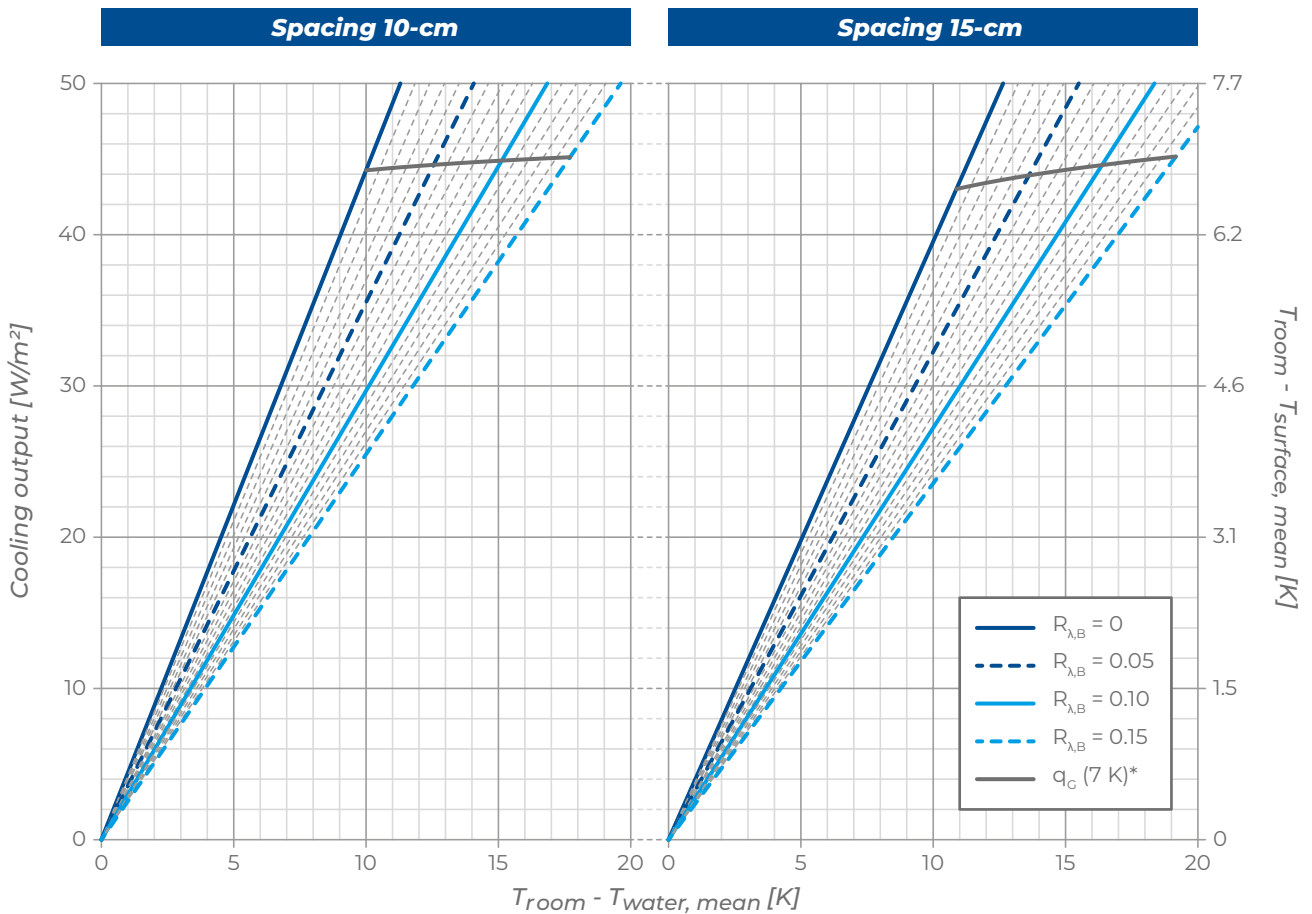

*valid only for room temperature = 26 °C

PRL AND PRL HP SYSTEMS

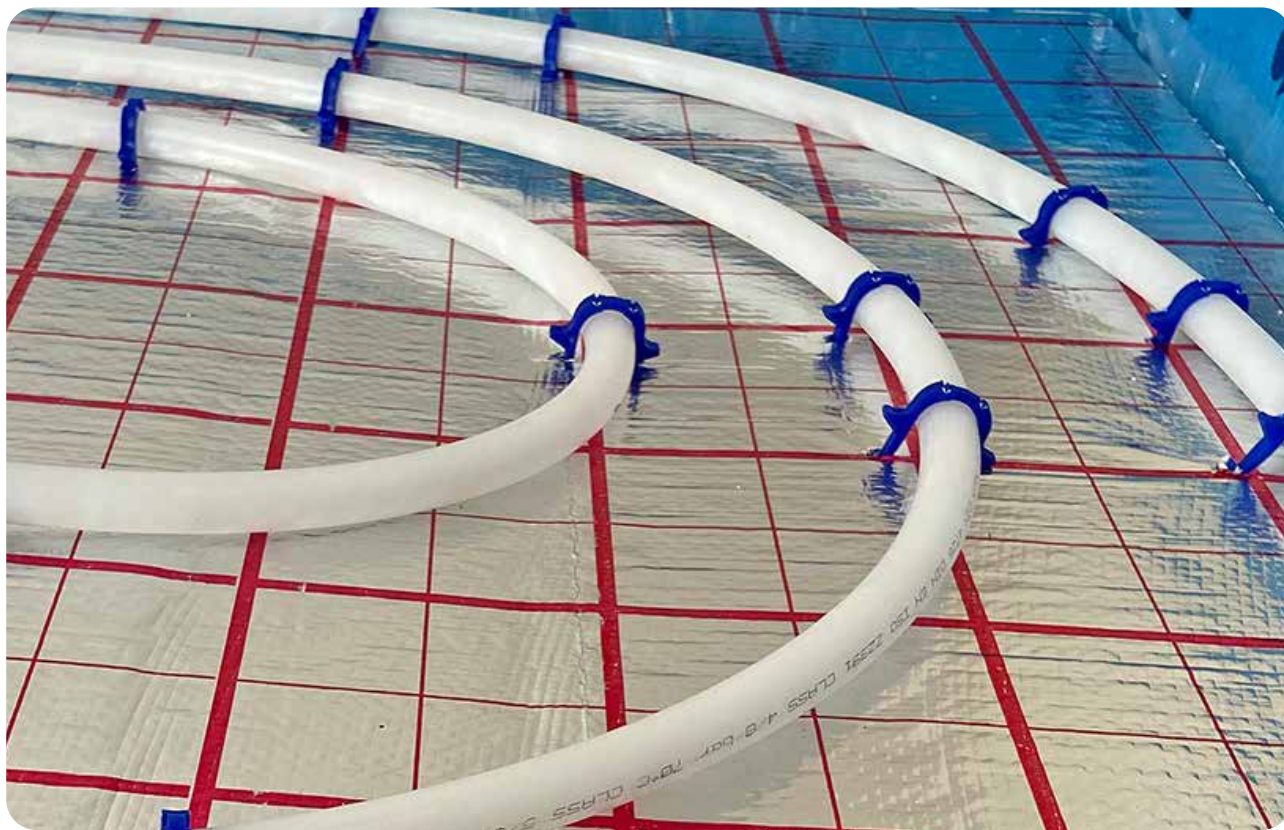

PRL and **PRL HP** are traditional underfloor heating and cooling systems, characterized by pipe anchored to the insulated base and embedded in the screed.

The central element of the systems is the smooth panel produced according to UNI EN 13163 and available in two versions. The first one made of waterproof expanded polystyrene (PRL) and the second made of waterproof expanded polystyrene with graphite for increased thermal insulation performances (PRL HP). The surface coating is made with a PET screen-printed to facilitate the laying of the pipe. The panels overlaps on two sides, therefore the foil layer is continuous and they are provided in rolls to make the installation of the system quickly.

The systems are completed by RDZ Tech PE-Xa Ø17 mm and Ø 16 mm pipe, RDZ Easy PE-RT Ø 17 pipe or RDZ Multilayer Easy PE-RT Ø 16 pipe, the hooked clips, the open support elbows, the manifold, the Easy 15 perimeter belt and the 4S thermo-fluidifying additive.

FEATURES

- Smooth panels in rolls available in two versions: with waterproof expanded polystyrene (PRL) or with waterproof expanded polystyrene and graphite (PRL HP)
- surface coating made with a PET screen-printed to facilitate the laying of the pipe
- Suitable for residential and commercial applications
- Easy and quick installation

SECTION AND DIMENSIONS

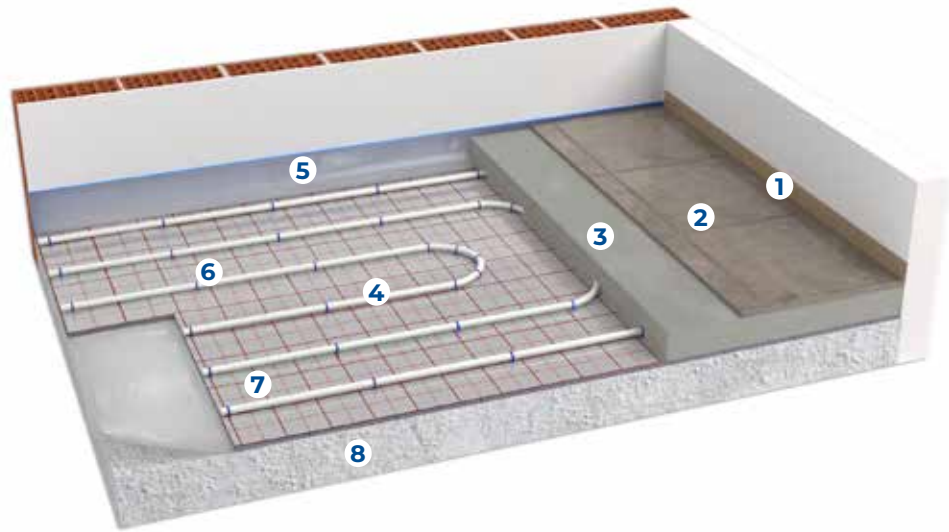

- 1 Skirting board
- 2 Flooring
- 3 Concrete
- 4 Easy PE-RT Pipe
- 5 Plus perimeter belt
- 6 Hooked clip
- 7 PRL panel
- 8 Substrate + levelling

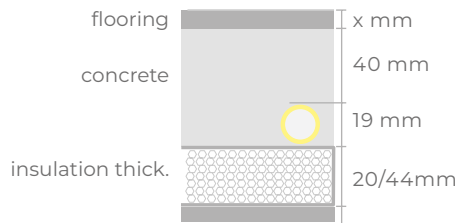

PRL System - Indicative quotas

Panel thickness	20 mm	27 mm	44 mm
Quote with Tiles - Parquet flooring	8.9 - 9.9 cm	9.6 - 10.6 cm	11.3 - 12.3 cm
Quote with Marble - Blockboard flooring	9.9 - 10.9 cm	10.6 - 11.6 cm	12.3 - 13.3 cm

PRL HP System - Indicative quotas

Panel thickness	20 mm	27 mm	30 mm	38 mm
Quote with Tiles - Parquet flooring	8.9 - 9.9 cm	9.6 - 10.6 cm	9.9 - 10.9 cm	10.7 - 11.7 cm
Quote with Marble - Blockboard flooring	9.9 - 10.9 cm	10.6 - 11.6 cm	10.9 - 11.9 cm	11.7 - 12.7 cm

Installation notes

- If the floor is in direct contact with the ground (i.e. without a sanitary void or insulating sheathing), provide a polyethylene sheet to act as a humidity barrier.
- Check that the site is clear and clean
- Check the dimensions available, taking into consideration the thickness of the insulation, screed and flooring chosen.
- Lay the perimeter belt and the insulation panels
- Lay the pipe according to the circuit paths specified in the project and fix it with clips
- Usually, it's not necessary to bend the pipe with a bending radius of less than 12.5 cm, i.e. with a laying pitch of less than 25 cm
- Test the system and leave it under pressure until all subsequent works are completed

Note: Please refer to the installation manual for more information.

PRODUCTS THAT COMPOSE THE SYSTEM

PRL HP Panel



PRL HP smooth insulating panels are used in underfloor heating systems to support the hydraulic circuits. Quick and easy to install, they are suitable for any type of pipe. The panels are made of closed-cell sintered expanded polystyrene, EPS class 200 with graphite. A PET film is applied to the insulating material, with geometric patterns to ease the pipe laying at spacing of 50 mm and 100 mm. The roll panel is also equipped with overlapping edges. CFC-free and CE marking according to UNI EN 13163.

SIZE	THICKNESS	CODE
100x1000 cm	20 mm	1054520
100x1000 cm	23 mm	1054523
100x1000 cm	30 mm	1054530
100x1000 cm	38 mm	1054538

Properties	Level/ Class	Panel (mm)				Unit	Standard
		20	23	30	38		
Necessary Length		10000				mm	UNI EN 13163:2015
Necessary Width		1000					
Total Thickness		20	23	30	38		
Orthogonality	S(2)	± 2				mm/m	
Planarity	P(5)	5					
Thermal conductivity at 10 °C	λ_D	0.030				W/(m·K)	
Thermal resistance	R_D	0.65	0.75	1.00	1.25	(m ² ·K)/W	
Compressive resistance at 10% deformation	CS(10)150	$\sigma_{10} \geq 150$				kPa	
Flexural Strength	BS200	≥ 200				kPa	
Water vapour resistance factor		$\mu = 30 \div 70$					
Water absorption by total immersion	WL(T) 2	≤ 2				%	
Steam water permeability		$\delta = 0.009 \div 0.020$				mg/(Pa·h·m)	
Duration of the fire reaction against aging and/or degradation		Fire performance for EPS does not change as time goes by					
Duration of the thermal resistance against aging and/or degradation		EPS thermal conductivity does not change as time goes by					
Reaction to fire for the product as it is sold on the market		Euroclass E					
Size stability 23 °C , 50% R.H.	DS(N)2	± 0.2				%	
Size stability in specific conditions of temperature and humidity 48h , 70 °C	DS(70,-)1	1				%	
Dynamic rigidity		NPD					
Compressibility		NPD					
Dangerous substances		NPD (EN standard test method is not available)					
Single identification code of the product							
T2-L3-W3-S2-P5-BS200-CS(10)150-DS(70,-)1-WL(T)2-MU(30-70)							

PRODUCTS THAT COMPOSE THE SYSTEM

PRL Panel



Smooth panel in expanded sintered polystyrene, produced in conformity with UNI EN 13163, combined with a silk-screened PET film for guiding the pipe laying. This panel is supplied in rolls with overlap selvedge, and allows the installation of pipe with spacing of 5 cm or multiples.

SIZE	THICKNESS	CODE
100x1000 cm	20 mm	1045420
100x1000 cm	27 mm	1045427
100x1000 cm	44 mm	1045444

Properties	Level/ Class	Panel (mm)			Unit	Standard
		20	27	44		
Necessary Length	L(3)	10000			mm	UNI EN 13163:2015
Necessary Width	W(3)	1000				
Total Thickness	T(2)	20	27	44		
Orthogonality	S(2)	± 2			mm/m	
Planarity	P(5)	5				
Thermal conductivity at 10 °C	λ_b	0.035			W/(m·K)	
Thermal resistance	R_b	0.55	0.75	0.85	(m²·K)/W	
Compressive resistance at 10% deformation	CS(10)100	$\sigma_{10} \geq 100$			kPa	
Water vapour resistance factor		$\mu = 30 \div 70$				
Water absorption by total immersion	WL(T) 1	≤ 1			%	
Steam water permeability		$\delta = 0.009 \div 0.020$			mg/(Pa·h·m)	
Duration of the fire reaction against aging and/or degradation		Fire performance for EPS does not change as time goes by				
Duration of the thermal resistance against aging and/or degradation		EPS thermal conductivity does not change as time goes by				
Reaction to fire for the product as it is sold on the market	Euroclass E					
Size stability 23 °C , 50% R.H.	DS(N)2	± 0.2			%	
Size stability in specific conditions of temperature and humidity 48h, 70 °C	DS(70,-)1	1			%	
Dynamic rigidity		NPD				
Compressibility		NPD				
Dangerous substances		NPD (EN standard test method is not available)				
Single identification code of the product						
T2-L3-W3-S2-P5-BS150-CS(10)100-DS(70,-)1-WL(T)1-MU(30-70)						

■ PRODUCTS THAT COMPOSE THE SYSTEM



RDZ Tech PE-Xa Pipe Ø 17 Interior Layer

RDZ Tech PE-Xa pipe Ø 17-13 made of high-density cross-linked polyethylene with the oxygen barrier between the PE-X layer and an outer layer made of PE, which ensures further protection during installation in the building site. The layers are combined thanks to a special glue.

TYPE	ROLL	CODE
PE-Xa	240 m	1013840
PE-Xa	600 m	1013850



RDZ Tech PE-Xa Pipe Ø 16

RDZ Tech Pipe PE-Xa Ø 16 is a crosslinked polyethylene pipe manufactured using the Organic Peroxide method, with EVOH oxygen barrier (5 layers) that prevents the permeability of the tube to oxygen diffusion, eliminating the problem of oxygen supply to the water flow and corrosion in the metal elements of the installation extending its lifetime. Diameter 16 mm - Thickness 2 mm.

TYPE	ROLL	CODE
PE-Xa	240 m	1013860
PE-Xa	600 m	1013870

Note: for further technical data see page 174



RDZ Easy PE-RT Pipe 5L Ø 17-13

RDZ EASY 5-layer PE-RT (non-crosslinked Polyethylene of Raised Temperature) provided with EVOH anti-oxygen according to DIN 4726, it is suitable for underfloor heating and cooling systems. Diameter 17 mm, Thickness 2 mm, Natural color.

TYPE	ROLL	CODE
PE-RT	240 m	1014754
PE-RT	600 m	1014756



RDZ Multilayer Easy PE-RT pipe Ø 16-12

PE-RT Type II/Al/PE-RT Type II multilayer pipe Ø 16x2 mm according to UNI EN ISO 21003. SKZ certified.

TYPE	ROLL	CODE
PE-RT/ALL/PE-RT	200 m	1020016



Easy 15 perimeter belt

Is the edge insulation, which absorbs floor expansions and acts as thermo-acoustic insulation for the walls. It is made of expanded polyethylene, and it is provided with an adhesive strip on one side, while on the other side it has a special polyethylene combined sheet in order to avoid infiltrations of mortar between belt and panel. This belt has small cuts on the backside to adjust its height.

SIZE	CODE
5x150 mm	1072150



Hooked clip

Hooked clips made of plastic material to ensure secure positioning of the pipe on the insulating panels.

PACKAGE	CODE
100 pieces	1017000



Open Elbow

Open elbow Ø17 made of plastic material. It is used to support the pipes near the manifolds vertically and to protect them from any damage.

SIZE	CODE
Ø 17 mm	1130517



Thermofluidifying Additive 4S

Superfluxing, multidosage, water reducing admixture for concrete to increase its workability and to improve its mechanical properties and thermal conductivity. It is a product which conforms to EN 934-2; T3.1 - 3.2.

SIZE	CODE
10 liters	1091911
20 liters	1091921

Tips for material calculation

Needed products	Requirements
PRL Panel or PRL HP	Area to be covered +3%.
RDZ Tech pipe Ø17	Depending on the average pitch. Total = area / pitch [m ² /m].
Easy 15 perimeter belt	1 metre per m ²
Open elbow Ø 17	2 for each circuit
Hooked clip	3 per metre of pipe

Optional products	Requirements
Fibreglass Mesh	Area to be covered +10%
RDZ Fiber (polypropylene fibres)	1 kg per 16 m ²
Clip 75	To be used only if anti-shrinkage net is used. 5 clips/m ²
Humidity Barrier Sheet	Surface to be covered +20%
Thermofluidifying Additive 4S	Approx. 0.2 litres per m ²
Inibitor XR20	2% of ENTIRE water content
Biocida XR40	1% of ENTIRE water content

Manifolds, heads, accessories and optional products (from page 160).

Note: The requirements in the table are indicative. Please refer to the construction project for confirmation..

THERMAL OUTPUT OF THE SYSTEM

Thermal output in heating

Input data			
Screed coverings above the pipe	s_U	0.045	m
Heat conductivity of screed	λ_E	1.2	W(m·k)
Piper external diameter	d_o	0.017	m
Pipe wall thickness	s_R	0.002	m
Pipe heat conductivity	λ_R	0.35	W(m·k)

T cm	K_H [m ² ·k]															
	$R_{\lambda,B}$ [m ² ·k/W]															
	0.00	0.01	0.02	0.03	0.04	0.05	0.06	0.07	0.08	0.09	0.10	0.11	0.12	0.13	0.14	0.15
8.3	6.811	6.332	5.917	5.554	5.233	4.948	4.693	4.463	4.255	4.066	3.893	3.734	3.587	3.452	3.327	3.211
16.6	5.345	5.009	4.719	4.466	4.243	4.045	3.860	3.694	3.544	3.408	3.284	3.165	3.054	2.953	2.859	2.772
24.9	4.225	3.990	3.787	3.611	3.457	3.321	3.188	3.070	2.963	2.867	2.779	2.689	2.607	2.531	2.461	2.396

$R_{\lambda,B}$: Heat conduction resistance of the floor covering
 T : Pipe spacing
 K_H : Equivalent thermal transmission coefficient

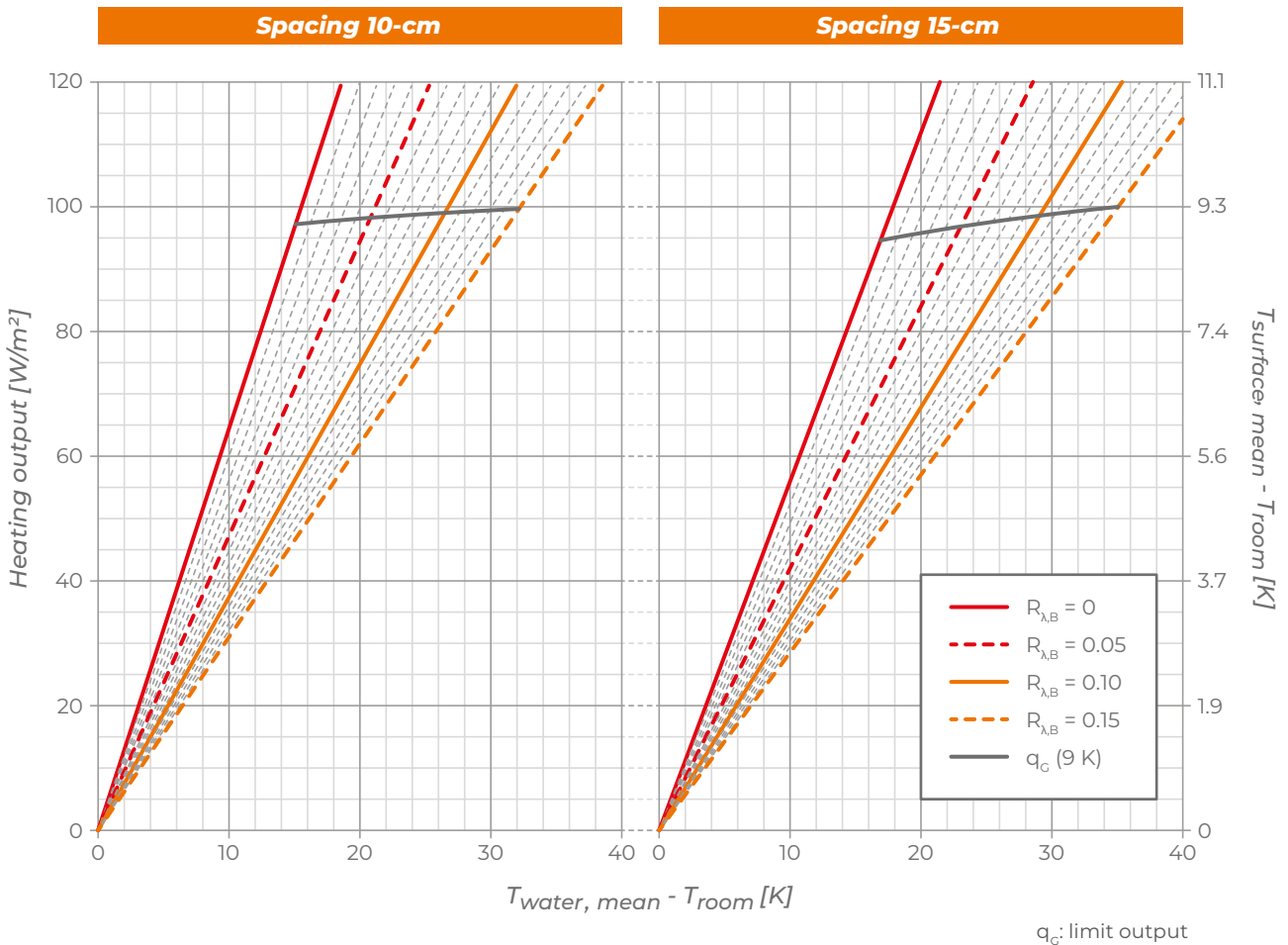

Thermal output in cooling

Input data			
Screed coverings above the pipe	s_U	0.045	m
Heat conductivity of screed	λ_E	1.2	W(m·k)
Piper external diameter	d_o	0.017	m
Pipe wall thickness	s_R	0.002	m
Pipe heat conductivity	λ_R	0.35	W(m·k)

K_H [m ² ·k]																
$R_{\lambda,B}$ [m ² ·k/W]																
T cm	0.00	0.01	0.02	0.03	0.04	0.05	0.06	0.07	0.08	0.09	0.10	0.11	0.12	0.13	0.14	0.15
8.3	4.672	4.444	4.237	4.049	3.877	3.718	3.573	3.438	3.313	3.197	3.088	2.987	2.892	2.803	2.720	2.641
16.6	3.876	3.709	3.557	3.416	3.286	3.165	3.054	2.949	2.852	2.761	2.675	2.595	2.519	2.448	2.380	2.316
24.9	3.221	3.101	2.989	2.885	2.788	2.698	2.613	2.533	2.458	2.387	2.321	2.258	2.198	2.141	2.087	2.036

$R_{\lambda,B}$: Heat conduction resistance of the floor covering
 T: Pipe spacing
 K_H : Equivalent thermal transmission coefficient

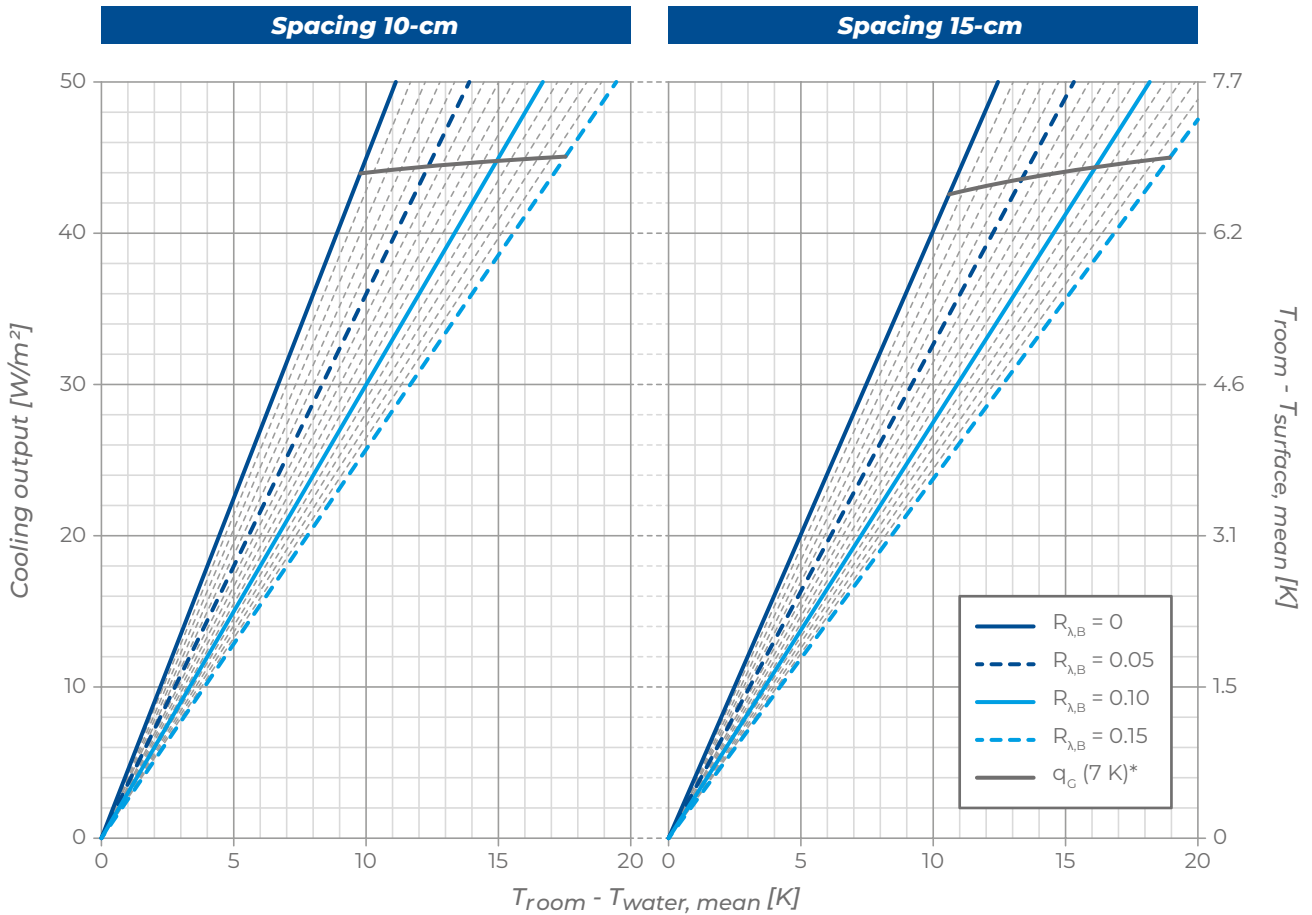

*valid only for room temperature = 26 °C



**Manifolds, pipes
and complements
for underfloor
radiant systems**



Complete, high-performance and efficient systems

Our pipes for underfloor heating and cooling systems are available in a wide range of variants, all characterised by excellent mechanical strength, outstanding corrosion resistance and low oxygen permeability. Flexible and easy to handle, they are also easy and fast to install.

The distribution manifolds allow to kept under control the Δt and the flow rate of either the system and the individual circuit. Available in brass or technopolymer, they can be supplied already assembled in their cabinet. As they are pre-assembled in the factory, they are easy to install and thanks to their reduced depth, they are also suitable for installation in hollow brick walls.

The underfloor systems are completed with a series of accessories designed to offer everything necessary to create high-performance, safe, long-lasting systems that can be customised according to installation and usage requirements.

ADVANTAGES OF MANIFOLDS AND COMPLEMENTS



**WIDE RANGE OF PIPES
SUITABLE FOR EVERY SYSTEM**



**EASY AND QUICK
INSTALLATION**



**WIDE RANGE
OF ACCESSORIES AND COMPLEMENTS**



**VERSATILE PRODUCTS THAT INCREASE
SYSTEMS EFFICIENCY**



Top Composit Pre-assembled Manifold

TOP COMPOSIT manifold Ø 1" is made of thermoplastic, and it is used to distribute the pipes into the rooms. It is provided with flow meters on each circuit, digital flow and return thermometers with a liquid-crystal display, on-off valves (suitable for electrothermal heads), micrometric lockshield valves with data labels to locate rooms, end fittings with ball air vent valves and ball drain valves with hose nozzles and plugs, brackets which can be installed in cabinets or fixed on the wall, and push-fit fittings for polyethylene pipes Ø 12, Ø 17 mm or Ø 16 mm multilayer.

Performance / size	Value	Unit
Liquid	water, glycolic water 30% at most	
Max. Operating Pressure	6	bar
Max. Testing Pressure	6	bar
Operating Temperature	5÷60	°C
Flowmeter Scale	1÷4 (±10%)	l/min
Main outlets of the manifold	1" F Distance between axis 210	Ø mm
Derivations	Push-fit Distance between axis 50	mm

outlets	Ø 12 PB	Ø 16 multilayer	Ø 17 PE-X
3+3	1181203	1181503	1181703
4+4	1181204	1181504	1181704
5+5	1181205	1181505	1181705
6+6	1181206	1181506	1181706
7+7	1181207	1181507	1181707
8+8	1181208	1181508	1181708
9+9	1181209	1181509	1181709
10+10	1181210	1181510	1181710
11+11	1181211	1181511	1181711
12+12	1181212	1181512	1181712
13+13	1181213	1181513	1181713
14+14	1181214	1181514	1181714
15+15	1181215	1181515	1181714

Dimension of the manifold														
Number of outlet		3+3	4+4	5+5	6+6	7+7	8+8	9+9	10+10	11+11	12+12	13+13	14+14	15+15
Only Top Composit manifold	cm	25.5	30.5	35.5	40.5	45.5	50.5	55.5	60.5	65.5	70.5	75.5	80.5	85.5
Top Composit + Ball Valves	cm	35.5	40.5	45.5	50.5	55.5	60.5	65.5	70.5	75.5	80.5	85.5	90.5	95.5
Top Composit + Zone Valve	cm	39	44	49	54	59	64	69	74	79	84	89	94	>100
Top Composit + Ball Valves + Zone Valve	cm	43.5	48.5	53.5	58.5	63.5	68.5	73.5	78.5	83.5	88.5	93.5	>100	>100



Push-Fit Pipe Fitting

Push-fit pipe fitting used to connect pipes Ø 17 mm with TOP COMPOSIT manifold. Supplied as standard with TOP COMPOSIT manifolds.

PACKAGE	SIZE	CODE
10 items	Ø 17	1185017



Eurocone Adapter Ø 3/4"

Pair of clutch Eurocone adapter Ø 3/4" to connect the pipes with TOP COMPOSIT manifold.

PACKAGE	SIZE	CODE
pair	Ø 3/4"	1186005



Contact Thermometer

Push-fit thermometers for pipes Ø 17 mm, temperature range 5-50 °C, provided with conductive paste.

PACKAGE	CODE
10 items	1185050

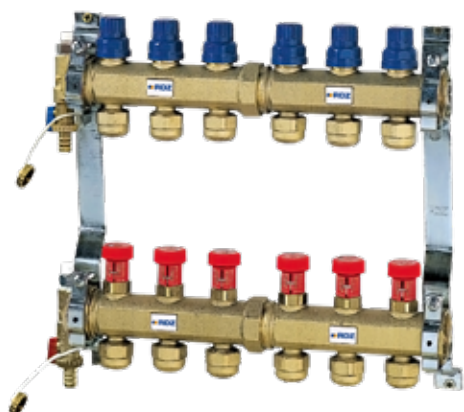

Control Pre-assembled Manifold

CONTROL manifolds Ø 1" 1/4 are made of brass, and they are used to distribute the pipes into the rooms. They are provided with on-off valves (suitable for electrothermic heads), micrometric lockshields with data labels to locate rooms, ball air vent valves and ball drain valves with hose nozzles and plugs, brackets with vibration-damping rubber tops, which can be installed in cabinets or on the wall, and fittings for pipes Ø 17 mm.

Performance / size	Value	Unit
Liquid	water, glycolic water 30% at most	
Max. Operating Pressure	6	bar
Max. Testing Pressure	10	bar
Operating Temperature	5÷100	°C
Main outlets of the manifold	1" 1/4 F distance between axis 210	mm
Derivations	pipe clamp fitting 3/4" 17 - 20 distance between axis 50	Ø mm

outlets	Ø 17 PE-X
3+3	1152803
4+4	1152804
5+5	1152805
6+6	1152806
7+7	1152807
8+8	1152808
9+9	1152809
10+10	1152810
11+11	1152811
12+12	1152812
13+13	1152813
14+14	1152814
15+15	1152815

Dimension of the manifold														
Number of outlet		3+3	4+4	5+5	6+6	7+7	8+8	9+9	10+10	11+11	12+12	13+13	14+14	15+15
Only control manifold	cm	24.5	29.5	35.5	41	46	51	56	61	67.5	72.5	77.5	82.5	87.5
Control + Initial Fittings	cm	28	33	39	44.5	49.5	54.5	59.5	64.5	71	76	81	86	91
Control + Ball Valves	cm	34.5	39.5	45.5	51	56	61	66	71	77.5	82.5	87.5	92.5	97.5
Control + Zone Valve	cm	38	43	49	54.5	59.5	64.5	69.5	74.5	81	86	91	96	>100
Control + Initial Fittings + Ball Valves	cm	38	43	49	54.5	59.5	64.5	69.5	74.5	81	86	91	96	>100
Control + Initial Fittings + Zone Valve	cm	41.5	46.5	52.5	58	63	68	73	78	84.5	89.5	94.5	>100	>100
Control + Ball Valves + Zone Valve	cm	42.5	47.5	53.5	59	64	69	74	79	85.5	90.5	95.5	>100	>100
Control with all accessories	cm	47	52	58	63.5	68.5	73.5	78.5	83.5	90	95	>100	>100	>100



Pair of Initial Fittings

Initial fittings provided with thermometers and pockets (0-60 °C), which can be installed into flow and return manifolds.

PACKAGE	SIZE	CODE
pair	Ø 1 ¼"	1053032



Measuring Unit for Flow and Temperature

Measuring device for flow and temperature (optional element for CONTROL manifolds). It is made of brass, and it is provided with a metal ring to activate the self-cleaning. PN 6. Flow rate 1÷4 litre a minute. Temperature 20÷40 °C.

PACKAGE	SIZE	CODE
pair	Ø 3/4"	1053040



Pair of Initial Insulation Shells for CONTROL Manifold

Pair (flow-return) of black insulating shells made of expanded polystyrene for the initial part of CONTROL manifolds. Suitable for installation in SLIM cabinets and thermoregulation KIT. Temperature range from -60 °C to 90 °C.

PACKAGE	SIZE	CODE
pair		1160151



Pair of 5-Outlet Insulation Shells for CONTROL Manifold

Pair (flow-return) of black insulating shells made of expanded polystyrene, provided with 5 outlets, for the central part of CONTROL manifolds. Suitable for installation in SLIM cabinets and thermoregulation KIT. Temperature range from -60 °C to 90 °C.

PACKAGE	SIZE	CODE
pair		1160155



Pair of End Insulation Shells for CONTROL Manifold

Pair (flow-return) of black insulating shells made of expanded polystyrene for the end part of CONTROL manifolds. Suitable for installation in SLIM cabinets and thermoregulation KIT. Temperature range from -60 °C to 90 °C.

PACKAGE	SIZE	CODE
pair		1160152

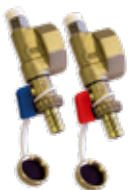

End Fittings

Pair of end fittings, provided with ball air vent valves and ball discharge valves with hose nozzles and plugs. They can be combined with manifold modules. Package: in pairs.

PACKAGE	SIZE	CODE
pair		1053132

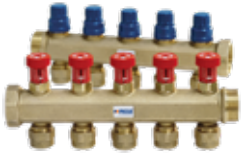

Flow + Return Manifold Modules

Pair of manifold modules (inflow + return), $\varnothing 1\frac{1}{4}$ ", made of brass to distribute the pipes into the rooms. They are provided with on-off valves (suitable for electrothermic heads), micrometric lockshields with data labels to locate rooms, and fittings for pipes $\varnothing 17-13$.

OUTLETS	PACKAGE	CODE
3	pair	1052903
4	pair	1052904
5	pair	1052905



Brackets

Pair of brackets with hose nozzles to install the manifolds into the cabinets or onto the wall.

PACKAGE	CODE
pair	1055102



Reducers for Manifolds

Brass reducer $\varnothing 1\frac{1}{4} - \frac{3}{4}$ " or $\varnothing 1\frac{1}{4} - 1$ ".

SIZE	PACKAGE	CODE
$\varnothing 1\frac{1}{4} - \frac{3}{4}$ "	pair	1171520
$\varnothing 1\frac{1}{4} - 1$ "	pair	1171525

Easy Steel Pre-assembled Manifold



Pre-assembled manifold Ø 1" made of stainless steel AISI 304, and used to distribute pipe into the rooms. It is equipped with on-off valves (suitable for electrothermic heads) on the return manifold, flow-meters with scale 0 to 5 L/m, digital flow and return thermometers with a liquid-crystal display, air vent valves and drain valves with hose nozzles and plugs, brackets with vibration-damping rubber tops, which can be installed into cabinet or onto the wall.

Available in BASE versions with eurocone outlets suitable for Eurocone 3/4" pipe connectors (to be supplied separately).

Performance / size	Value	Unit
Liquid	water, glycolic water 50% at most	
Max. Operating Pressure	6	bar
Max. Testing Pressure	6	bar
Operating Temperature	5÷55	°C
Main outlets of the manifold	1" F distance between axis 50	mm
Derivations	Eurocone M 3/4" Push-fit fittings 17	Ø mm

outlets	Easy Steel BASE
3+3	1426103
4+4	1426104
5+5	1426105
6+6	1426106
7+7	1426107
8+8	1426108
9+9	1426109
10+10	1426110
11+11	1426111
12+12	1426112
13+13	1426113
14+14	1426114
15+15	1426115

Dimension of the manifold														
Number of outlet		3+3	4+4	5+5	6+6	7+7	8+8	9+9	10+10	11+11	12+12	13+13	14+14	15+15
Only manifold	cm	23.5	28.5	34.5	40	45	50	55	60	66.5	71.5	76.5	81.5	86.5
Manifold + Ball Valves	cm	33.5	38.5	44.5	50.5	55	60	65	70	76.5	81.5	86.5	91.5	96.5
Manifold + Zone Valve	cm	37	42	48	53.5	58.5	63.5	68.5	73.5	80	85	90	91	100
Manifold + Ball Valves + Zone Valve	cm	41.5	46.5	52.5	58	63	68	73	78	84.5	89.5	94.5	99.5	104.5



Eurocone Connector

Eurocone fitting Ø 3/4" made of brass with nickel-plated nut for the connection between pipe and Easy Steel Base manifold.

SIZE	PACKAGE	CODE
Ø 14	10 items	1402074
(multil.) Ø 16	10 items	1402076
Ø 17	10 items	1042077



EK Connect or 3/4" for Easy Steel Manifold

This connector is used to change the 17-mm outlets in Rapid Easy Steel Base manifolds into Eurocone outlets.

SIZE	PACKAGE	CODE
Ø 3/4"	1 item	1402078

MANIFOLDS, PIPES AND COMPLEMENTS



Ball Valves

Pair of ball valves with total opening, diameter 1" M/F, and pipe unions for CONTROL and TOP COMPOSIT manifolds.

TYPE	SIZE	PACKAGE	CODE
straight	Ø 1"	pair	1053050
90°	Ø 1"	pair	1053051



Fittings for PE-X and PB pipe

Fittings used with CONTROL and TOP COMPOSIT manifolds. RDZ manifolds are already provided with pipe fittings.

SIZE	PACKAGE	CODE
Ø 12	1 item	1118212
Ø 17	1 item	1118216
Ø 20	1 item	1118218



Fittings for Multilayer pipe Ø 20

Fittings for multilayer. They can be used with b!klimax, CONTROL and TOP COMPOSIT manifolds.

SIZE	PACKAGE	CODE
Ø 20	1 item	1186120



Straight Fitting Ø ½" M x ¾" Eurocone

Straight fitting set to repair pipes. Size Ø ½" M x ¾" Eurocone.

SIZE	PACKAGE	CODE
Ø ½" M x ¾"	1 item	1118101
Ø ¾" x ¾"	1 item	1118100



Male Straight Fitting

Male straight pipe fitting for pipe Ø 17-13, Ø 20-16, Ø 25-20.4 mm.

SIZE	PACKAGE	CODE
Ø ½" x 17-13	1 item	1171005
Ø ½" x 20-16	1 item	2170120
Ø ¾" x 25-20.4	1 item	2170125



Double clamp connection

Double clamp coupling for pipe connection Ø 17-13. Suitable for use with clamp MT 56.

SIZE	PACKAGE	CODE
Ø 17-13	1 item	1141117



Y Fitting

Eurocone nickel-plated fitting Ø ¾" for the extension of one manifold outlet into 2 branch connectors.

SIZE	PACKAGE	CODE
Ø ¾"	1 item	1118102



Cabinet Body Slim

SLIM cabinet made of zinc-plated sheet iron, thickness 0.8 mm, with adjustable feet, height 70÷74, a net on the back, dead holes for side entrances, slide guides for brackets, a protective cover for plaster.

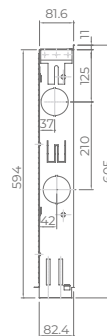
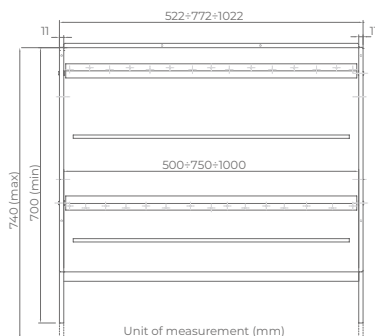

MODEL	CODE
Slim 50	1157650
Slim 75	1157675
Slim 100	1157699

Door and Frame Slim

White metal powder-coated frame and door with lockset for SLIM cabinet. Outward thickness 2 mm. 4 screws are supplied as standard, and they shall be used to fix frame and door to the cabinet body.



MODEL	SIZE FRAME	CODE
Slim 50	560x620x2 mm	1158300
Slim 75	810x620x2 mm	1158375
Slim 100	1060x620x2 mm	1158399

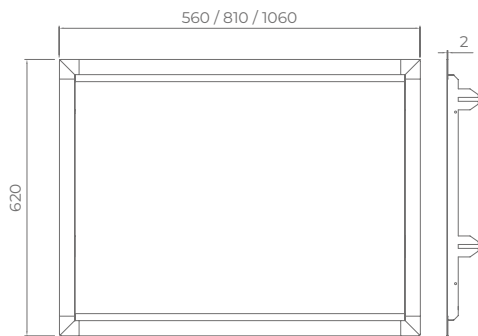

Smooth frame for Slim cabinet

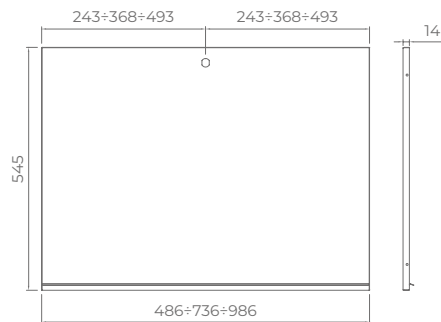

Door for Slim cabinet



Easy Cabinet

Recessed cabinet made of zinc-plated sheet metal, depth 8 cm, with adjustable feet, a net on the back, dead holes for side entrances, slide guides for a pair of brackets, a protective cover for plaster. It includes flat frame and door made of pre-covered metal sheet and screw-driver lockset.

MODEL	CODE
Easy 50	1600550
Easy 75	1600575
Easy 100	1600599
Easy 120	1600600

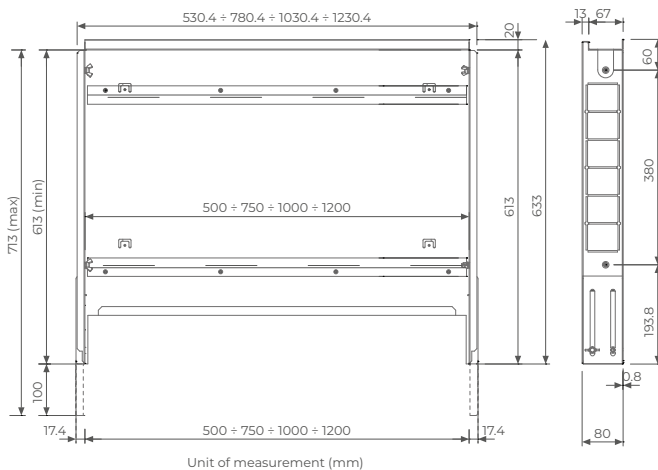

Unit of measurement (mm)

Mixing Group PF



Mixing module suitable for the regulation and control of small underfloor heating systems. It includes a mixing valve with temperature range up to 50 °C (for heating only), electronic circulation pump, one-way valve, balancing bypass, piping for the connection with Easy Steel manifolds, brackets to fix the Mixing Group into the cabinet. High-temperature outlets are NOT available.

PACKAGING	CODE
1 Item	3130066

Overall Dimensions of the Manifold and “MIXING GROUP” Cabinet for “EASY STEEL” Manifolds.

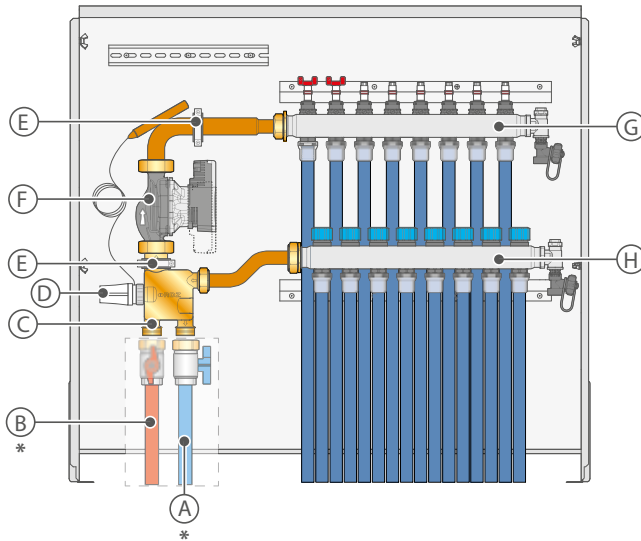

- A F3/4" water production return
- B F3/4" water production supply
- C Mixing unit
- D Thermostatic element
- E Fixing Collars
- F Self-adjusting Electronic Circulator
- G Water supply manifold
- H Water return manifold
- * Provide shut-off valve

Number of outlets	3+3	4+4	5+5	6+6	7+7	8+8	9+9	10+10	11+11	12+12	13+13	14+14
Mixing Group + EASY STEEL Manifold	85 cm					120 cm						

Overall Dimensions of the Manifold and “MIXING GROUP” Cabinet for “TOP COMPOSIT” Manifolds

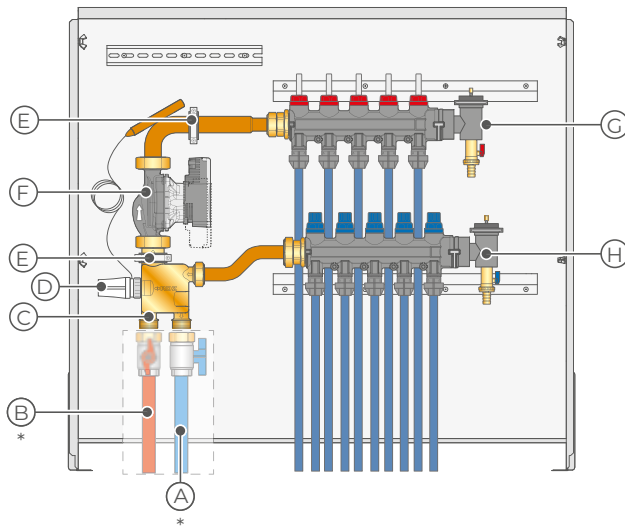

- A F3/4" water production return
- B F3/4" water production supply
- C Mixing unit
- D Thermostatic element
- E Fixing Collars
- F Self-adjusting Electronic Circulator
- G Water supply manifold
- H Water return manifold
- * Provide shut-off valve

Number of outlets	3+3	4+4	5+5	6+6	7+7	8+8	9+9	10+10	11+11	12+12	13+13
Mixing Group + Top Composit Manifold	85 cm					120 cm					

Cabinet for Mixing Group



Recessed cabinet made of zinc-plated sheet metal, suitable for the installation of the Mixing Group. It is equipped with adjustable feet, metal mesh for plaster, slide guides for brackets, a protective cover for plaster and DIN rail for any accessories such as control bars. It includes flat frame and door made of pre-covered metal sheet and screw-driver lockset.

SIZE LXHXP	CODE
850x750x110 mm	3121085
1200x750x110 mm	3121120

Connection Kit Ø 1"



Double screws Ø 1" for the connection between Mixing Group and Easy Steel or Top Composit manifold.

MODEL	CODE
for Easy Steel manifold	1185016
for Top Composit manifold	1185015

RDZ Electrothermic Head



The thermo-electric actuator performs the shut-off function on each circuit with control by the room thermostat. It can be installed in any position, even upside-down. The function display of the actuator allows identifying the operating condition (open/closed). Easy slot assembly thanks to the adapter (supplied as standard). Voltage: 230V with or without micro-switch or 24V with micro-switch. Protection class: IP54 (all assembly positions). It can be used with b!klimax, TOP COMPOSIT, CONTROL and High-Temperature outlets for KITS.

VOLTAGE	CODE
230 V	1057230
230 V w/micro	1057240
24 V w/micro	1057250

Technical specifications	230 V	24 V
Operating voltage	230 V AC, +10%...-10%, 50/60 Hz	24 V AC/DC, +20%...-10%
Max. inrush current	< 550 mA in 100 ms max.	< 300 mA in max. 2 min
Operating power	1 W *	1 W *
Stroke (actuator travel)	4.0 mm	4.0 mm
Actuating force	100 N ±5%	100 N ±5%
Connection line	type: 2 x 0.75 mm ² PVC, colour: light gray (RAL 7035), length: 1 m	type: 4 x 0.75 mm ² PVC, colour: light gray (RAL 7035), length: 1 m

* measured with precision reference instrument LMG95

RDZ Easy electrothermic head



Thermoelectric actuator for an energy saving regulation of surface heating and cooling system

VOLTAGE	CODE
230 V	1055222
230 V c/micro	1056222

Technical specifications	230 V
Operating voltage	230 V AC, +10%...-10%, 50/60 Hz
Max. inrush current	< 300 mA during 200 ms max.
Operating power	1.8 W
Stroke (actuator travel)	4.5 mm
Actuating force	100 N
Connection line	type: 2 x 0.75 mm ² PVC, colour: RAL 9003, length: 1 m

Electrical connection

Electrothermal head

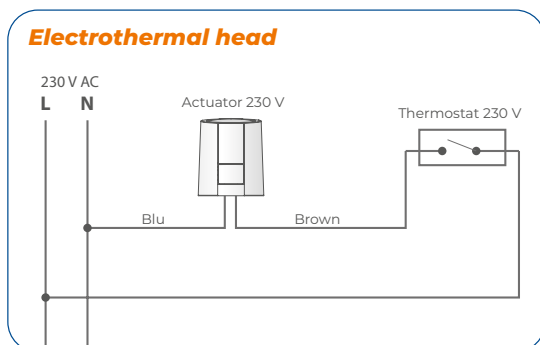

Electrothermic head with micro

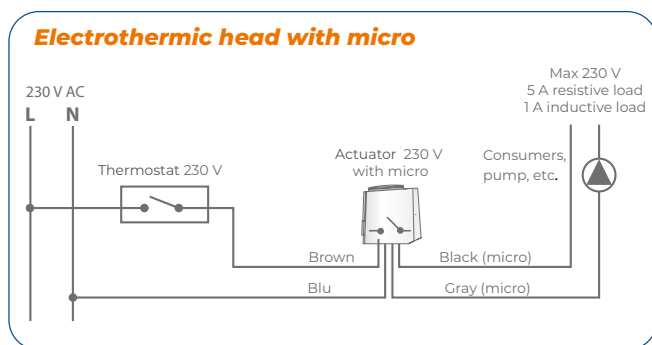

Air Trap

Air traps are used to vent constantly out air from the hydraulic circuits in radiant heating and cooling systems. Venting power of these devices is very high. They make it possible to vent all the air in the circuits, including bubbles, automatically.



With horizontal connections

FLOW RATE	SURFACE	SIZE	CODE
1.9 m ³ /h	up to 60 m ²	Ø 3/4"	6440020
2.6 m ³ /h	up to 85 m ²	Ø 1"	6440025
5.3 m ³ /h	up to 175 m ²	Ø 1 1/4"	6440032
6.3 m ³ /h	up to 210 m ²	Ø 1 1/2"	6440040
9.0 m ³ /h	up to 300 m ²	Ø 2"	6440050

With vertical connections

FLOW RATE	SURFACE	SIZE	CODE
1.9 m ³ /h	up to 60 m ²	Ø 3/4"	6440021
2.6 m ³ /h	up to 85 m ²	Ø 1"	6440026

Operating principle

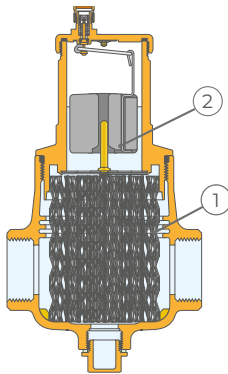

The deaerator uses the combined action of several physical principles. The active part consists of an assembly of concentric metal mesh surfaces (1). These elements create the whirling movement required to facilitate the release of micro-bubbles and their adhesion to these surfaces.

The bubbles, fusing with each other, increase in volume until the hydrostatic thrust is such as to overcome the adhesion force to the structure. They rise towards the top of the unit from which they are released through a float-operated automatic air release valve (2). It is designed in such a way that the direction in which the medium is flowing inside it makes no difference.



for Quota Zero AD and Super D system

RDZ Clima PB Pipe Ø 12 mm

RDZ Clima pipe Ø 12 made of polybutylene with anti-oxygen barrier, excellent flexibility for easy installation on low-temperature systems. It is produced in compliance with DIN 16968 and DIN 4726.

DIAMETER	ROLL	CODE
12 mm	300 m	1115120

Application field	CLASS 4	For use with hot and cold water (T_{max} 60 °C)
	CLASS 5	For use with hot and cold water (T_{max} 80 °C)

Outside diam. (mm)	Thickness (mm)	Weight (g/m)	CLASS 4 (bar)	CLASS 5 (bar)	Water content (l/m)
12	1.3	50	10	10	0.069

Pipe Feature	Value	Unit	Standard
Standard			DIN 16968
Oxygen tightness	≤ 0.32	mg O ₂ / (m ² · d)	DIN 4726
Degree of cross-linking	≥ 70	%	
Density	0.920	g/cm ³	ISO 1183
Thermal expansion coefficient at 20 °C	1.3 · 10 ⁻⁴	m/(m·K)	
Thermal conductivity	0.22	W/(m·K)	
Softening temperature	> 130	°C	
Elongation at break a 20 °C	> 300	%	ISO 8986-1
Ultimate Tensile Stress at 20 °C	19	MPa	ISO 8986-2
Max operating temperature	90	°C	
Installation temperature	> -5	°C	
Roughness factor	0.007		

RDZ Tech PE-Xa Pipe Interior Layer Ø 16 mm

RDZ Tech Pipe PE-Xa Ø 16 is a crosslinked polyethylene pipe manufactured using the Organic Peroxide method, with EVOH oxygen barrier (5 layers) that prevents the permeability of the pipe to oxygen that may cause corrosion of metallic parts in the system. This pipe has a 75% average crosslinking degree that allows major traction and pressure resistance, better stability to temperature variations, installation flexibility and chemical resistance to solvents, air and water. Pipe is certified by the main European Institutes (AENOR, SKZ, CSTB, IIP) complying with the UNE-EN ISO 15875:2004 European regulations and ISO 9001.



for all traditional systems excluding Acurapid

Features

DIAMETER	ROLL	CODE
16 mm	240 m	1013860
16 mm	600 m	1013870

Stratigraphy

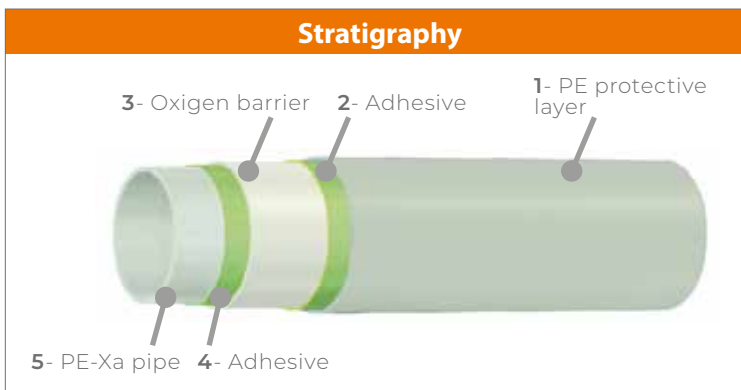

Application field			
PE-Xa pipe according to the European regulation UNE-EN ISO 15875:2004 European regulations and ISO 9001	CLASS 4	Heating with radiant panels	T _{max} 70 °C
	CLASS 5	Radiators for high temperature	T _{max} 90 °C

Outside diam. (mm)	Thickness (mm)	Weight (g/m)	Ovality (mm)	CLASS 4 (bar)	CLASS 5 (bar)	Water content (l/m)
16 + 0,3	2 + 0,3	90	0,9	10	8	0.113

	Pipe Feature	Value	Unit
Physical characteristics	Density	951	Kg/m ³
	Degree of crosslinking	> 75	% weight
	Roughness factor	0,007	mm
Thermal characteristics	Maximum service temperature	95	°C
	Maximum high temperature	110	°C
	Heat reversion 120 °C heat; 1 hour	< 2,5	%
	Specific heat at 23 °C	2,3	KJ/(Kg·K)
	Thermal conductivity	0,35 ÷ 0,38	W/(m·K)
	VICAT temperature	130 ÷ 132	°C
	Permeability O ₂	0,08	g/(m ³ ·d)
Mechanical characteristics	Linear extension coefficient	0,026	mm/(m·K)
	Tensile resistance	> 22	N/mm ²
	Elongation at break	> 400	%
	Modulus of elasticity at 20 °C	> 800	N/mm ²
	Internal pressure resistance s=2.5 Mpa, 110 °C	> 1	Year



for e-Dry Tech and e-Dry Evo system

Multilayer PE-RT Pipe Ø 16 mm

PE-RT Type II/Al/PE-RT Type II multilayer pipe Ø 16x2 mm according to UNI EN ISO 21003. SKZ certified. Suitable for use in radiant heating and cooling systems.

Features

THICKNESS	ROLL	CODE
2 mm	200 m	1020016
2 mm	300 m	1030016

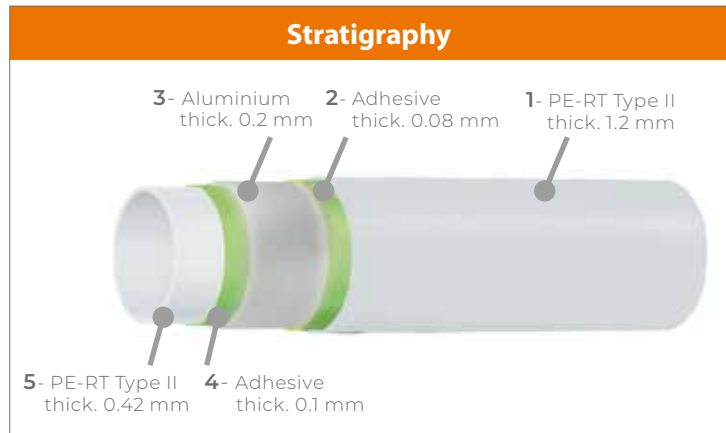

Application field				
Operating conditions according to: UNI EN ISO 21003	CLASS 2	Domestic hot water (70 °C)	T _{max} 80 °C	Pressure 10 bar
	CLASS 4	Underfloor heating and radiators low temperature	T _{max} 70 °C	Pressure 10 bar

d_n (mm)	e_n (mm)	Water content (l/m)
16	2	0.113

d_n = outer diameter, e_n = wall thickness

Pipe Feature	Value	Unit
Thickness aluminum layer	0.2	mm
Maximum ovalization	0.8	mm
Weight	110	g/m
Roughness factor	0.007	mm
Thermal conductivity	0.45	W / m · K
Thermal expansion coefficient	0.026	mm/m · °C
Permeability to oxygen	0.00	mg / l · h
Radius of curvature	up to 5 times the diameter	



for all traditional systems excluding Acurapid

RDZ TECH PE-HD-Xc pipe Ø 17

Tubo in polietilene reticolato ad alta densità, con barriera anti-ossigeno secondo DIN 4726 conforme alle normative DIN EN ISO 21003/2 o DIN EN ISO 15875/2.

DIAMETER	ROLL	CODE
17 mm	240 m	1011240
17 mm	600 m	1011600

Stratigraphy



Application field	CLASS 4	Heating with radiant panels (T_{max} 70 °C)	Pressure 8 bar
	CLASS 5	Radiators for high temperature (T_{max} 90 °C)	Pressure 8 bar

d_n (mm)	e_n (mm)	S-value	SDR-value	Water content (l/m)
17	2	4	9	0.130

d_n = outer diameter, e_n = wall thickness,
S = nominal pipe serial number according to ISO 4065, SDR = standard dimension ratio, allocation of SDR values, according to DIN 16893 and/or DIN EN ISO15875-2

Pipe Feature		Value	Unit	Standard
Degree of cross-linking	23°C	≥ 60	%	DIN 16892
Density	23°C	≈ 0.94	g/cm ³	DIN 16892/DIN 53479
Flexural impact strength according to Charpy	23°C	no failure	kJ/m ²	DIN EN ISO 179-1/2
Tensile strength	23°C	24 ÷ 30	N/mm ²	DIN EN ISO 6259-1
Tenacity	23°C	24 ÷ 26	N/mm ²	DIN EN ISO 6259-1
Elongation at break	23°C	400 ÷ 600	%	DIN EN ISO 6259-1
Elastic modulus (Emodule)	23°C	600 ÷ 800	N/mm ²	DIN 16892/DIN EN ISO 128
Stress crack resistance		no failure		ASTM D 1693
Moisture absorption		< 0.01	mg (4d)	DIN EN ISO 62
Coefficient of linear expansion	0°C – 70°C	1.5 · 10 ⁻⁴	1/K	DIN 16892 / DIN 53752
Thermal conductivity		≤ 0.41	W/(K · m)	DIN 16892 / DIN EN 12664
Smallest bend radius		≥ 5 · D	mm	DIN 4726
Oxygen tightness	40 °C	≤ 0.32	mg/(m ² · d)	DIN 4726



for all traditional systems excluding Acurapid

EASY PE-RT and EASY-C PE-RT pipe

RDZ EASY 5-layer (non-crosslinked Polyethylene of Raised Temperature) provided with EVOH anti-oxygen according to DIN 4726, it is suitable for underfloor heating and cooling systems. Diameter 16 / 17 mm, thickness 2 mm, natural color.

CERTIFICATION	DIAMETER	ROLL	CODE
AENOR/SKZ	16 mm	240 m	1014651
AENOR/SKZ	16 mm	600 m	1014650
AENOR/SKZ	17 mm	240 m	1014754
AENOR/SKZ	17 mm	600 m	1014756
SKZ	17 mm	240 m	1014751
SKZ	17 mm	600 m	1014750

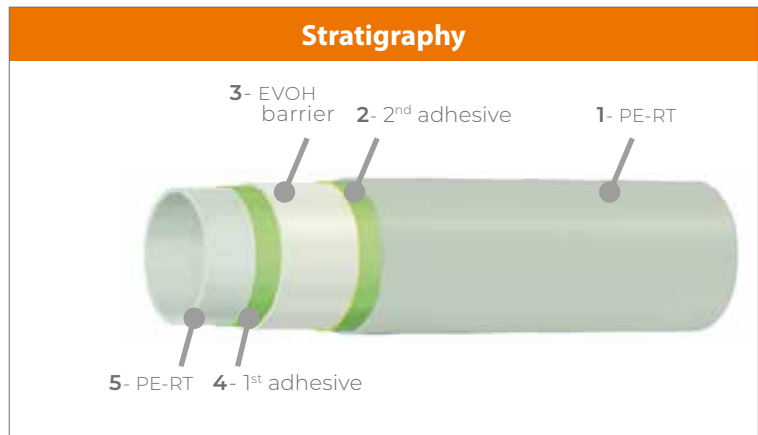

Application field	CLASS 4	For use with hot and cold water (T_{max} 70 °C)	pressure 8 bar
	CLASS 5	For use with hot and cold water (T_{max} 90 °C)	pressure 6 bar

d_n (mm)	e_n (mm)	Water content (l/m)
16	2	0.113
17	2	0.130

d_n = outer diameter, e_n = wall thickness,

Pipe Feature	Value	Unit
Density	> 941	Kg/m ³
Roughness factor	0,007	mm
Tensile resistance	> 22	N/mm ²
Elongation at break	> 400	%
Thermal expansion coefficient	1,8	10 ⁻⁴ /K
Thermal conductivity at 60°C	0,41	W / m · K
VICAT softening point	124,7	°C
Oxidation induction time (OIT)	> 40	min
Permeability O ₂ at 40 °C	< 0,1	g/ m ³ · d



for all traditional systems excluding Acurapid

RDZ Tech PE-Xa Pipe Ø 17 mm

RDZ Tech Pipe PE-Xa Ø 17 is a crosslinked polyethylene pipe manufactured using the Organic Peroxide method, with EVOH oxygen barrier (5 layers) that prevents the permeability of the tube to oxygen diffusion, eliminating the problem of oxygen supply to the water flow and corrosion in the metal elements of the installation extending its lifetime. This pipe with an average greater than 70% of crosslinking degree provide major traction and pressure resistance, better stability under extreme temperature conditions, more flexibility and chemical resistance to solvents, oils and water without incrustations, corrosion or aging. Certified with the UNE-EN ISO 15875:2004 European regulations and ISO 9001.

DIAMETER	ROLL	CODE
17 mm	240 m	1013840
17 mm	600 m	1013850

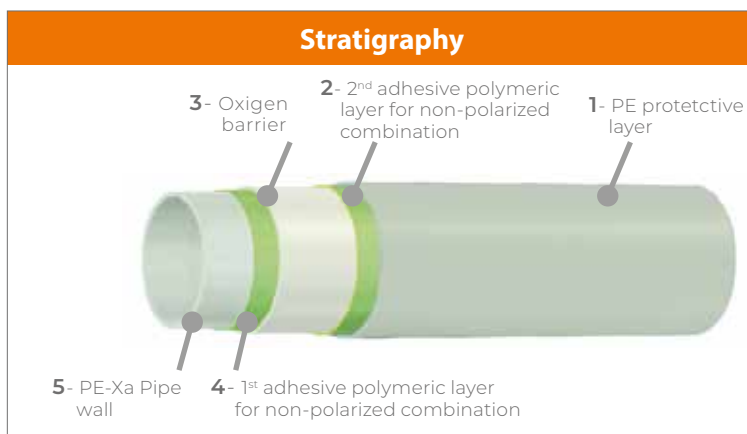

Application field	CLASS 4	For use with underfloor heating and low temperature radiators (T _{max} 70 °C)
	CLASS 5	For use with high temperature radiators (T _{max} 90 °C)

Outside diam. (mm)	Thickness (mm)	Weight (g/m)	CLASS 4 (bar)	CLASS 5 (bar)	Water content (l/m)
17	2	96	10	8	0.131

Pipe Feature	Value	Unit	Standard
Density	951	Kg/m ³	UNI EN ISO 15875: 2004 and ISO 9001
Degree of crosslinking	> 70	% weight	
Roughness factor	0.007	mm	
Thermal conductivity	0.35÷0.38	W/(m·K)	
VICAT temperature	130÷132	°C	
Permeability O ₂	0.08	g/(m ³ ·d)	
Coefficient of linear expansion	0.026	mm/(m·K)	
Tensile resistance	> 22	N/mm ²	
Elongation at break	> 400	%	
Modulus of elasticity at 20 °C	> 800	N/mm ²	
Internal pressure resistance s=2.5 Mpa, 110 °C	> 1	Year	



for Acurapid system

Rapid PE-RT pipe Ø 17 mm

RDZ 17-13 polyethylene pipe with EVOH oxygen diffusion barrier which complies with DIN 4726. It consists in 5 layers PE-RT II/EVOH/PE-RT II ensuring outstanding flexibility & easy handling. A micro-interlocking band is helically wound around the pipe. Certifications: SKZ A820

DIAMETER	ROLL	CODE
17 mm	600 m	1013890

Application field					
Operating conditions according to: DIN EN ISO 15875-1	CLASS 4	Underfloor heating and low temperature radiators	T _{des} 40 °C	20 years	Pressure 8 bar
	CLASS 5	High temperature radiators	T _{des} 60 °C	25 years	Pressure 6 bar

d _n (mm)	e _n (mm)	Weight (g/m)	Water content (l/m)
17	2	94	0.133

dn = outer diameter, en = wall thickness,

Pipe Feature	Value	Unit	Standard
Density	> 941	Kg/m ³	UNI EN ISO 22391
Roughness factor	0,007	mm	
Maximum ovality	0.8	mm	
Tensile strength	> 22	N/mm ²	
Elongation at break	> 400	%	
Thermal Conductivity at 60 °C	0.40	W/(m·K)	
Oxygen permeability at 40 °C	< 0.1	g/(m ³ ·d)	
Linear expansion coefficient	1.8	10-4/K	
Oxidation induction time (OIT)	> 40	min	
VICAT Softening point	124.7	°C	
Heat reversion 120 °C heat, 1 hour	< 2.0	%	
Maximum service temperature	95	°C	
Certifications	SKZ A820		



RDZ Tech pipe PE-Xc Ø 20 mm

High density cross-linked polyethylene pipe with anti-oxygen barrier according to DIN 4726 in accordance with DIN EN ISO 15875/2.

DIAMETER	ROLL	CODE
20 mm	240 m	1012240
20 mm	600 m	1012600

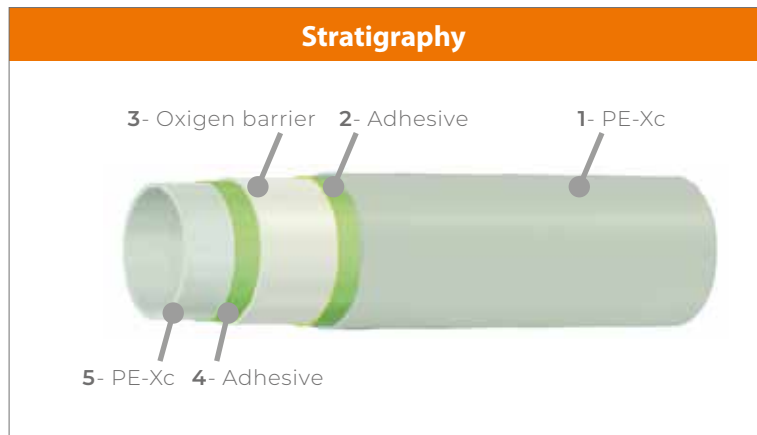

Application field	CLASS 4	For use with hot and cold water (T _{max} 70 °C)
	CLASS 5	For use with hot and cold water (T _{max} 90 °C)

Outside diam. (mm)	Thickness (mm)	Weight (g/m)	CLASS 4 (bar)	CLASS 5 (bar)	Water content (l/m)
20	2	120	8	6	0,20

Pipe Feature	Value	Unit	Standard
Standard			DIN EN ISO 15875 / DIN 4726
Density	0.945	g/cm ³	ISO 1183
Degree of cross-linking	≥ 60	%	
Ultimate Tensile Stress at 20 °C	24-26	N / mm ²	UNI EN ISO 527-2 / EN 60811-1
Elongation at break a 20 °C	400 ÷ 600	%	DIN EN ISO 6259-1 / EN 60811-1
Thermal conductivity	0.41	W / (m · K)	DIN 52612
Oxygen tightness	≤ 0.32	mg O ₂ / (m ² · d)	DIN 4726
Thermal expansion coefficient at 20 °C	1.5 · 10 ⁻⁴	m / (m · K)	
Softening temperature	> 130	°C	
Maximum ovalization	1.2	mm	
Roughness factor	0.0015		

OTHER COMPLEMENTS



Fibreglass Mesh

Alkali-proof fibreglass mesh to reinforce concrete. Pattern: 40x70 mm.

Clip 75

The fixing clips are made of plastic material and they are used to secure the reinforcement mesh.

SIZE	CODE
100x200 cm	1092100
	CODE
	1111002

Fibreglass mesh characteristics	Value	Unit	Standard
Sheet dimensions	1000x2000	mm	UNI 9311/2
Medium thickness coated fabric	0.95	mm	UNI 9311/3
Mesh size (internal measurements)	40x70	mm	UNI 9311/2
Raw fabric weight	110	g/m ²	UNI 9311/4
Finished fabric weight	130	g/m ²	UNI 9311/4
Construction: Warp Weft	2x25 25	Wires/10 cm Wires/10 cm	UNI 9311/1 UNI 9311/1
Elongation at break	2.8	%	UNI 9311/5
Tensile breaking load: Warp Weft	>2.940 >1.330	N N	UNI 9311/5 UNI 9311/5



RDZ Fiber

Consists in macro synthetic fibres produced through polypropylene extrusion. It is used to improve the bond within the concrete, thus increasing its workability and strength. Is suitable for concrete on underfloor heating and cooling systems to partially or totally replace the reinforcement mesh.

PACKAGE	CODE
2 bags of 1.5 Kg	1060110

Fiber characteristics	Value	Unit
Diameter	0.75	mm
Fibre length	29	mm
Length/diameter ratio	37.17	
Color	transparent	
Density	~ 1	g/cm ³
Tensile resistance	400 - 450	N/mm ²
Elastic modulus	4003	MPa
Water absorption	null	
Acids/alkalis resistance	high	
Fiber number per kg	~ 70000	



Humidity Barrier Sheet

The polyethylene sheet should be laid under the insulating panel, thus acting as a humidity barrier.

SIZE	PACKAGE	CODE
Th. 0.18 mm	custom	1901100
Th. 0.18 mm	100 m ²	1901250

Humidity Barrier Sheet Features	Standard	Value		Unit	Tolerance
		1901100	1901250		
Width		4	2	m	± 3 %
Length		-	50	m	± 1.5 %
Thickness	ISO 4593-93	180		μ	± 10 %
Density	ASTM D 1505	0.923		g/cm ³	± 0.005 %
Softening temperature	ASTM D 1525	103		°C	
Water vapour diffusion resistance factor μ	EN 12086	89900		μ	

ACUSTIC INSULATION FOR SUBSTRATES



ACU UTL-M

Acoustic matting with high adhesion power composed mainly of natural materials such as rubber and cork that is able to attenuate impact noise under cladding in a thickness of only 2 mm. Suitable for stone, ceramic, resilient and multilayer parquet floor coverings.

SIZE	THICKNESS	CODE
20 m ²	2 mm	1054233

Features	Valor	U.M.	Standard
Length	20	m	
Height	1	m	
Thickness	2	mm	
Thermal resistance	0.024	m ² K/W	
Material	Cork and recycled rubber		
Elongation at break	20	%	EN ISO 1798
Tensile strength	0.6	N/mm ²	EN ISO 1798
Cohesion of pull-off tested material	> 0.5	N/mm ²	
Emission of volatile organic substances (VOC)	EMICODE EC1 Plus very low emission	EMICODE	
Decreased impact noise with ceramics - LW	10 (*)	dB	UNI EN ISO 10140-3
Decreased impact noise with parquet flooring - LW	13 (*)	dB	UNI EN ISO 10140-3



ACU UPL-M

An acoustic mattress with high clinging power composed mainly of 60% recycled synthetic fibres, which special production and processing procedures have made it possible to obtain a product with high noise reduction performance in the presence of low loads such as for low-inertia radiant systems.

SIZE	THICKNESS	CODE
24 m ²	4 mm	1054231

Features	Valor	U.M.	Standard
Length	15	m	
Height	1.6	m	
Thickness	4	mm	
Noise reduction with ACU UPL-M (*)	28.90 dB	ΔL _{nw}	UNI EN ISO 16283-2 EN ISO 717-2
Thermal conductivity	0.038 W/mK	λ	UNI EN 12667:2002
Thermal resistance	0.309 m ² K/W	R _D	
Density	162 Kg/m ³ ± 5%	ρ	
Vapour resistance factor	34	μ	UNI EN 12086:2013
Equivalent air thickness	0.14 m	S _d	
Coefficient of restitution	0.303	e	UNI EN ISO 10545-5
Certified Oeko tex Standard 100	Class 1		

(*) Data obtained with ACU UPL-M acoustic mantle installed under a SUPER D radiant system with 10 mm levelling and ceramic top coat.





ACU UPL-T

Single-sided acrylic adhesive tape with TNT, grey in colour, specifically for sealing and jointing underfloor acoustic coverings. Suitable for floating floors as well as for stone floors or thermal insulation floors whose installation requires the use of adhesives or glues.

Suitable for ACU UPL-M system.

ROLL	CODE
25 m	1054232

Mattress compatibility summary / low-thickness systems						
Mattress	RAPID US	Neo Super D17	SUPER D	ZERO LEVEL AD	e-DRY TECH	e-DRY EVO
 ACU UTL-M	✓	✓	✓	✓	-	✓
 ACU UPL-M	✓	✓	✓	-	✓	✓



Dilation Joint

Dilation joint with adhesive base made of expanded polyethylene. It is ideal to cut the concrete, for example, at the doorway, in order to guarantee the right dilation. Its upper part shall be leveled out once the screed is ready.

SIZE HXL	CODE
100 mm x 2 m	1054220

Joint features	Value	Unit
Length	2000	mm
Height	100	mm
Thickness	7.5 ÷ 9.5	mm
End thickness	30	mm
Dimensional tollerances	± 10	%
Cell structure	Closed cells	
Specific weight	50	kg/m ³
Compressive strength at 10% deformation	9.6	kPa
Standard color	Red	
CFC (freon) free. In compliance with L .549 of 28/12/93		



Biocide XR40

This sanitiser provides protection for surface heating and cooling systems against bacterial and fungal contamination. Such contamination can cause blockages in some parts of the installation, for example in the pipes, manifolds, valves or heat exchanger. Non-corrosive substance, easy and quick to dose. Biocide XR40 is compatible with Inibitor XR20, and they shall be both used at first fill of the radiant system in the primary circuit.

SIZE	CODE
3 liters	1091301

Dosage	Application instructions
BIOCIDE XR40 should be dosed at 1% of the water volume, i.e. 1 litre per 100 litres of water content in the system. The 3-litre pack satisfies a typical civil heating system: 80-140 m ² house, underfloor heating system and/or radiators.	For an empty system introduce the product at any point in the system before loading water. For a full system, use a dosing device to inject BIOCIDE XR40 at an access point to the system. Permanent treatment: leave in the system.



Inibitor XR20

The inhibiting treatment provides protection for heating systems against corrosion. It can be used in installations with aluminium components, and it is suitable for any kind of installation.

SIZE	CODE
3 liters	1091105
10 liters	1091111

Dosage	Application instructions
INIBITOR XR20 should be dosed at 2% of the water volume, i.e. 2 litres per 100 litres of water content in the system. The 3-litre pack satisfies a typical civil heating system: 15- 25 kW boiler, 80-140 m ² house, underfloor heating system and/or radiators. For larger systems, 10 litre packs can be used. An excess of product is not a problem.	For an empty system, introduce the product at any point in the system before filling with water. For a full system, use a dosing device to inject Inibitor XR20 at an access point to the system. Permanent treatment: leave in the system.



Protect-No Freeze

Antifreezing additive with inhibiting treatment to control corrossions, encrustations and the microbiological growth in any kind of heating system, included those systems containing aluminium components.

The dosage of PROTECT - NO FREEZE depends on the level of rotection against the cold climate:
 Dosage: 20% suitable up to -6 °C
 Dosage: 30% suitable up to -11 °C
 Dosage: 35% suitable up to -15 °C.

SIZE	CODE
20 liters	1091221

Dosage	Application instructions
The PROTECT - NO FREEZE dosage depends on the desired level of frost protection. A dosage of 20% on the volume of water in the system will protect up to -6 °C, 30% up to -11 °C, 35% up to -15 °C. For best results, it is recommended to rinse the system thoroughly before applying PROTECT - NO FREEZE.	PROTECT - NO FREEZE can be introduced directly at any point in the system, e.g. through a vent valve, or from the expansion tank. Permanent treatment: leave in the system.



Superwash SWR 20

SUPERWASH SWR 20 is the treatment to remove sludge made up of residual corrosion products in heating systems. It can be used in installations with aluminium components too. After using it, empty out the system and rinse it out until the water is clear. Dosage: 1% of the quantity of water in the system.

SIZE	CODE
3 liters	1091404
10 liters	1091411

Dosage	Application instructions
SUPERWASH SWR20 should be dosed at 2% of the water volume, i.e. 2 litres per 100 litres of water content in the system. The 3-litre pack satisfies a typical civil heating system: 15-25 kW boiler, 80-140 m2 house, floor heating system and/or radiators. For larger systems, 10-litre packs can be used. Overdosing does not pose any risk.	Circulate with all radiator valves open and the pump at maximum flow. This can be done either hot or cold and should be continued until satisfactory circulation is re-established. This can take between 2 hours and 2 weeks depending on the severity of the problem. After use, empty the system and rinse until the water is clear. To avoid the formation of sludge, the use of INIBITOR XR20 is recommended. Non-permanent treatment: empty the implant after use.

Site equipment



Unwinder

Unwinder made of tropicalized steel, provided with ball bearings to guarantee optimal rotation. It is adjustable according to the dimensions of the roll. It can be completely disassembled, and it is ideal for 600-m rolls.

CODE

1201000



Multiclip Fixer

Multiclip fixer to secure RDZ piping made of PE-X Ø 14-10, 17-13, 20-16 mm on smooth panels with relevant clips. By switching the guide you can install different kinds of clips (the colour of the matrix shall be the same as the colour of the clips). The fixer is supplied with black guide as standard.

MODEL	COLOUR	CODE
Multiclip fixer with guide for black clips on smooth insulating panels	black	2040002
multiclip die		
3 mm wire mesh pipe Ø14 or 17	gray	2040003
multiclip die		
6 mm wire mesh pipe Ø17 or 20	red	2040004



Manometer

Pressure gauge for reading the pressure during the system test phase, complete with fittings for installation on the system drain/load tap. Suitable for all manifold types.

PACKAGE	CODE
---------	------

1 item	2019025
--------	---------



Handle for Calibrators

Handgrip for pipe flaring tool.

PACKAGE	CODE
---------	------

1 item	1010015
--------	---------



Flaring Tool for Pipe Ø 12-17-20

Calibrator to adjust pipes diameter before using it with push-fit fittings.

SIZE	PACKAGE	CODE
Ø 12x1.3 mm	1 item	1130510
Ø 17x2.0 mm	1 item	1010017
Ø 20x2.0 mm	1 item	1010020



Pipe cutter

Made of plastic material.
Package: 1 item.

SIZE	PACKAGE	CODE
Ø 0÷28 mm	1 item	2019000



Thermoregulation devices

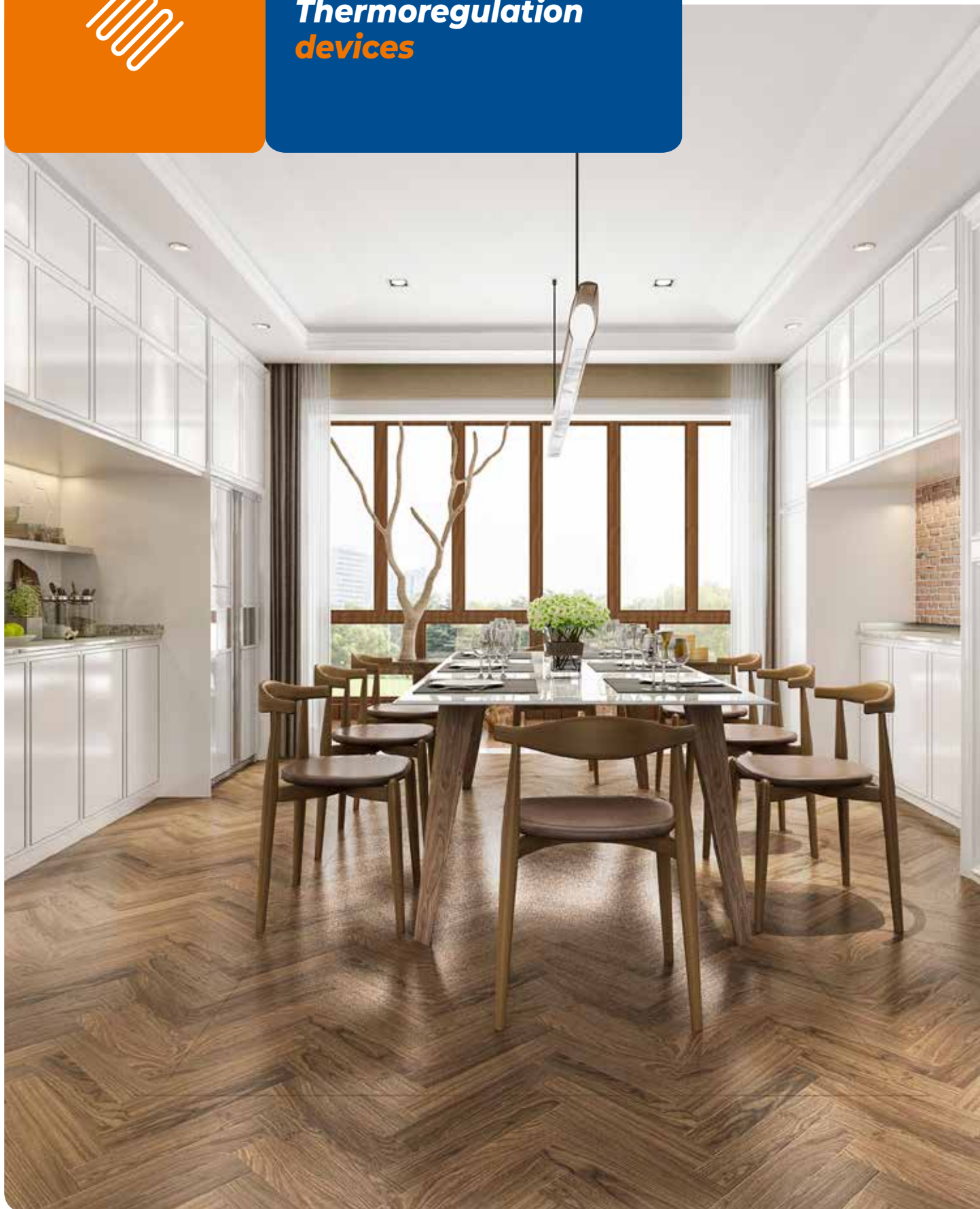



Controlled **efficiency**

The correct functioning of a radiant system passes through the choice of the right thermoregulation device which, in addition to guaranteeing the maximum performance of the system, must be able to be easily installed even where space is limited.

For this reason, in order to reduce the overall dimensions and facilitate the preparation of the technical room, we propose a wide range of solutions dedicated to the regulation of the system's parameters, capable of constantly guaranteeing high comfort, maximum efficiency and energy saving.

GM mixing units, compact and easy to install, contain a high-efficiency circulator and a mixing valve for managing the system supply temperature. The GR direct supply unit, on the other hand, can be combined with the GM module to manage heating and cooling in dual temperature systems.

Standard kits are complete and compact substations containing all the necessary components for regulating a radiant underfloor system, they work with wall-mounted boilers equipped with a circulator and allow the connection of high-temperature heating radiators.

ADVANTAGES OF THERMOREGULATION DEVICES



**HIGH COMFORT
IN EVERY BUILDING**



**MAXIMUM EFFICIENCY
OF THE SYSTEM**



**OPTIMISING CONSUMPTION
AND ENERGY SAVING**



**REDUCED
OVERALL DIMENSIONS**



GM PF mixing unit is a central heating device for distributing the thermovector fluid in radiant floor, wall and ceiling systems used only for heating.

The flow temperature is regulated by a fixed-point mixing valve with thermostatic element.

Inside the unit there is a high-efficiency electronic circulator with variable flow rate and head, which ensures low power consumption.

The unit is completed with two shut-off valves with thermometers respectively installed on the supply and return lines of the system, an insulating shell in PPE and a non-return valve to prevent undesired circulations inside the systems with a forced-opening device.

The mixing unit can also be mounted in a multiple version on a wall-mounted manifold.

FEATURES

- Fixed point mixing valve with thermostatic element (range 20 to 55 °C)
- Electronic circulator with variable flow rate and head
- Hydraulic connections Ø 1" M generator side and Ø 1" F system side (DN 25)
- Hydraulic connections Ø 1¼" M generator side and Ø 1¼" F system side (DN 32)
- Hydraulic connection centre distance: 125 mm
- Maximum temperature: 95 °C
- Maximum operating pressure: 8 bar
- Supply voltage: 230V - 50 Hz
- Water flow rate: 1500 l/h with 3 m.w.g. (DN 25)
- Water flow rate: 2200 l/h with 3.5 m.w.g. (DN 32)

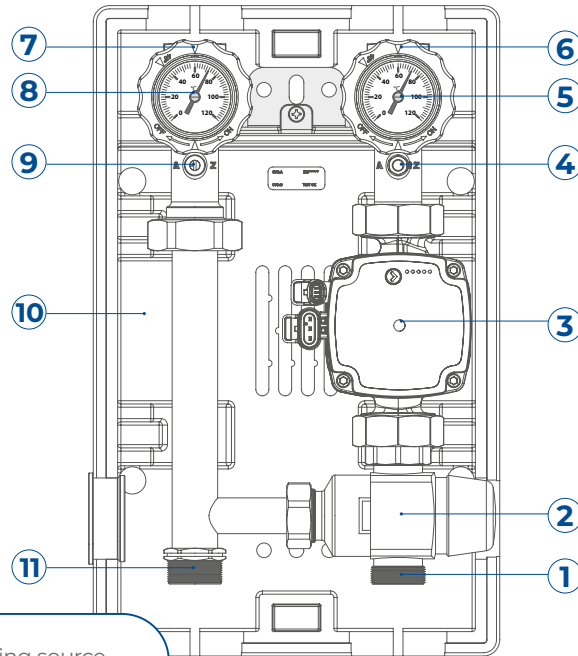

- 1 Water inlet from water heating source
- 2 Fixed point mixing valve
- 3 Circulator
- 4 Probe/safety thermostat holder
- 5 Supply water thermometer with ball valve
- 6 Water supply to the system
- 7 Water return from the system
- 8 Return thermometer with ball valve and non-return valve
- 9 Device for forcing normally open non-return valve
- 10 PPE insulating shell
- 11 Water return to water heating source

DN	CODE
25	3800122
32	3800150

Technical data		Unit	GM PF DN 25	GM PF DN 32
Hydraulic circuit	Max Flow Rate	l/h	1500	2200
	Mixer Kvs		4,5	4,8
	Max Temperature	°C	95	
	Max Pressure	Bar	8	
	Liquid		Water / Water + glycol max 30%	
Electrical characteristic	Power supply voltage		230 V – 50 Hz	
	Max electrical absorption	W	63	151
Mechanical characteristics	Shut-off valves		DN 25	DN 32
	Generator side connections		1"	1" ¼
	System side connections		1"	1" ¼
	Distance between connections	mm	125	
	Dimensions l x h x p	mm	250x400x210	
	Weight	kg	5,3	5,6

Example
Thermoregulation with the use of GM PF unit

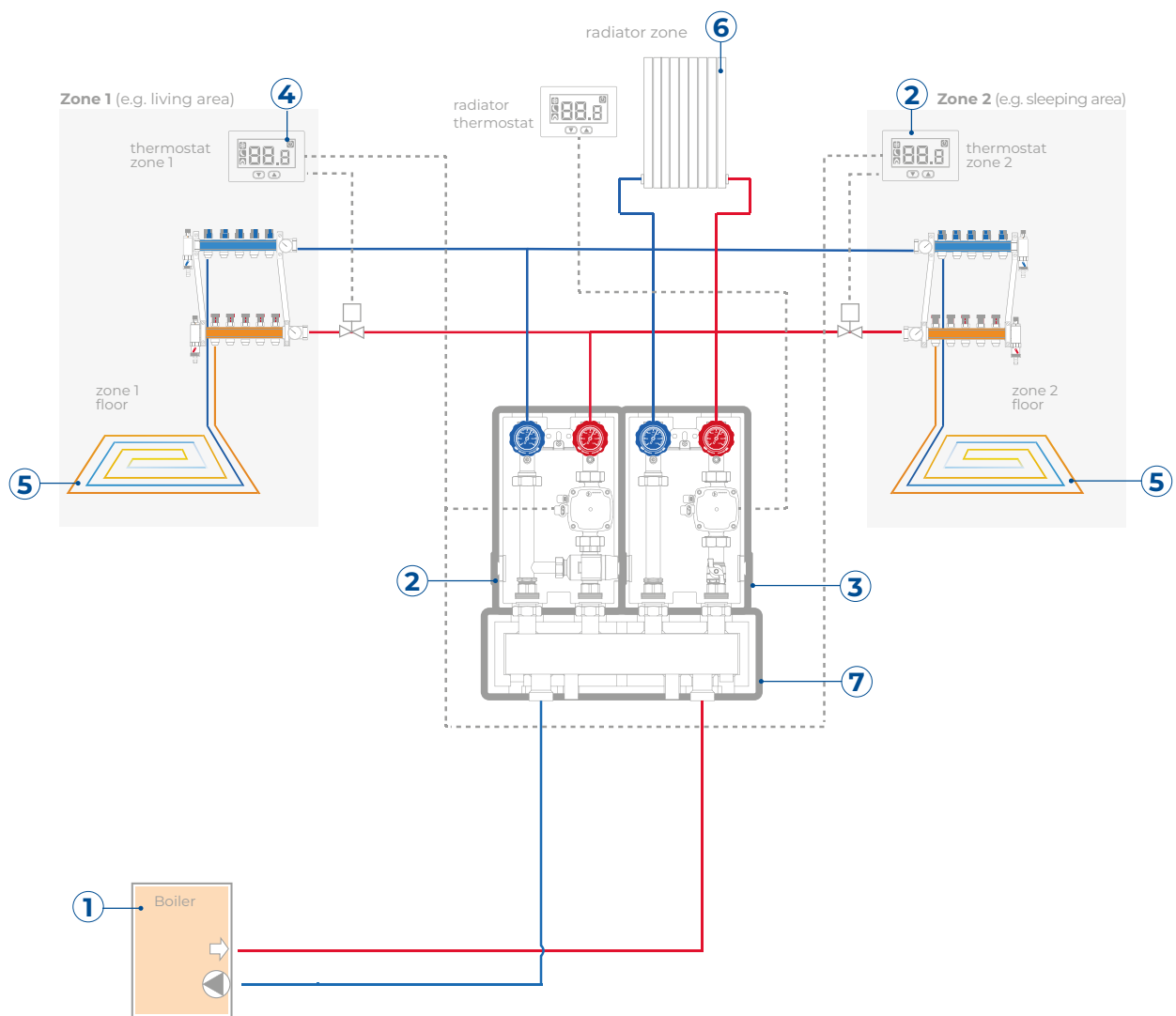

- 1 Boiler
- 2 Mixing unit GM PF
- 3 Direct supply unit GR
- 4 Room thermostat
- 5 Radiant underfloor or ceiling system
- 6 Radiator
- 7 ZZ-CS manifold

The proposed layout is indicative

■ HYDRAULIC PERFORMANCES

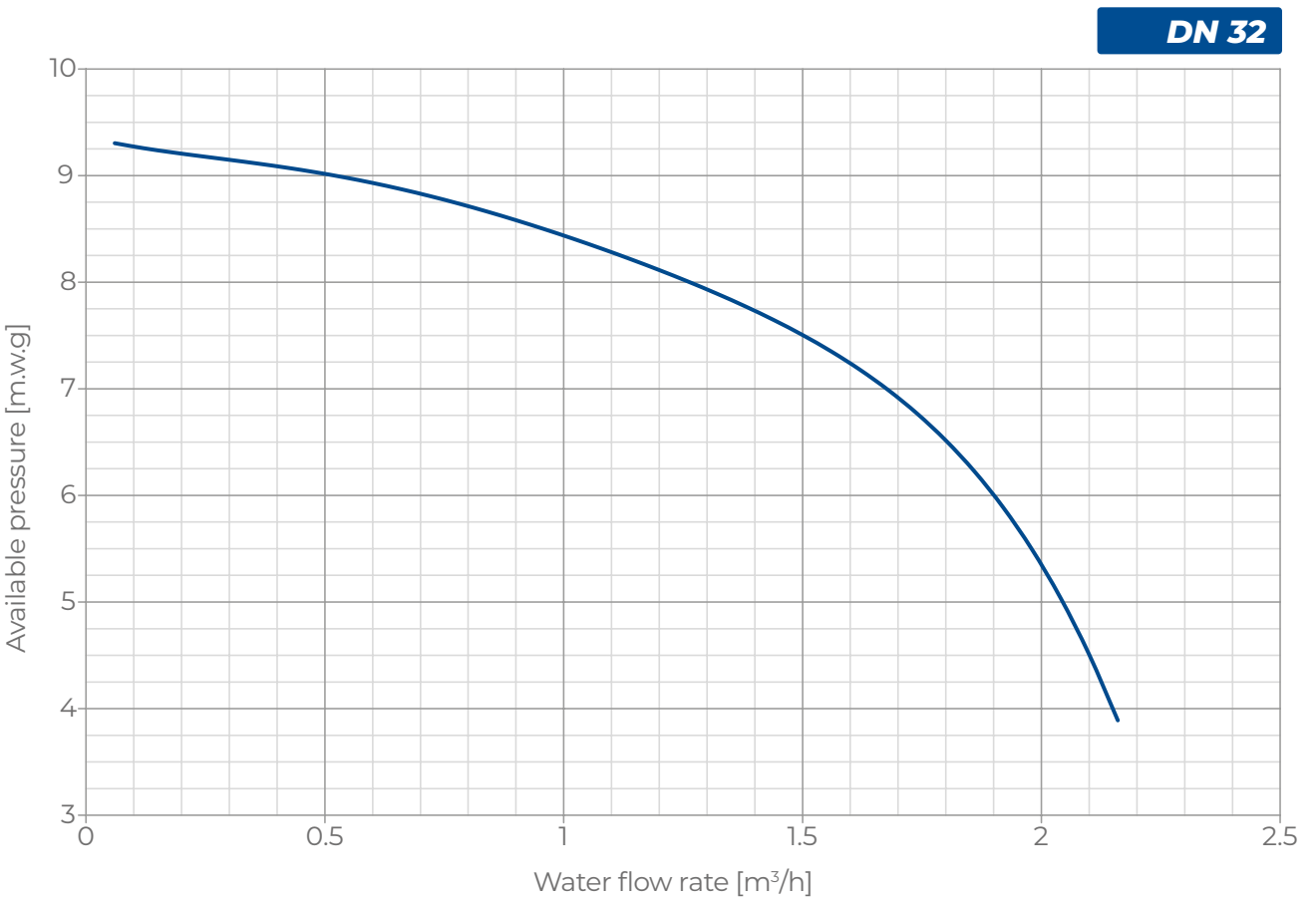
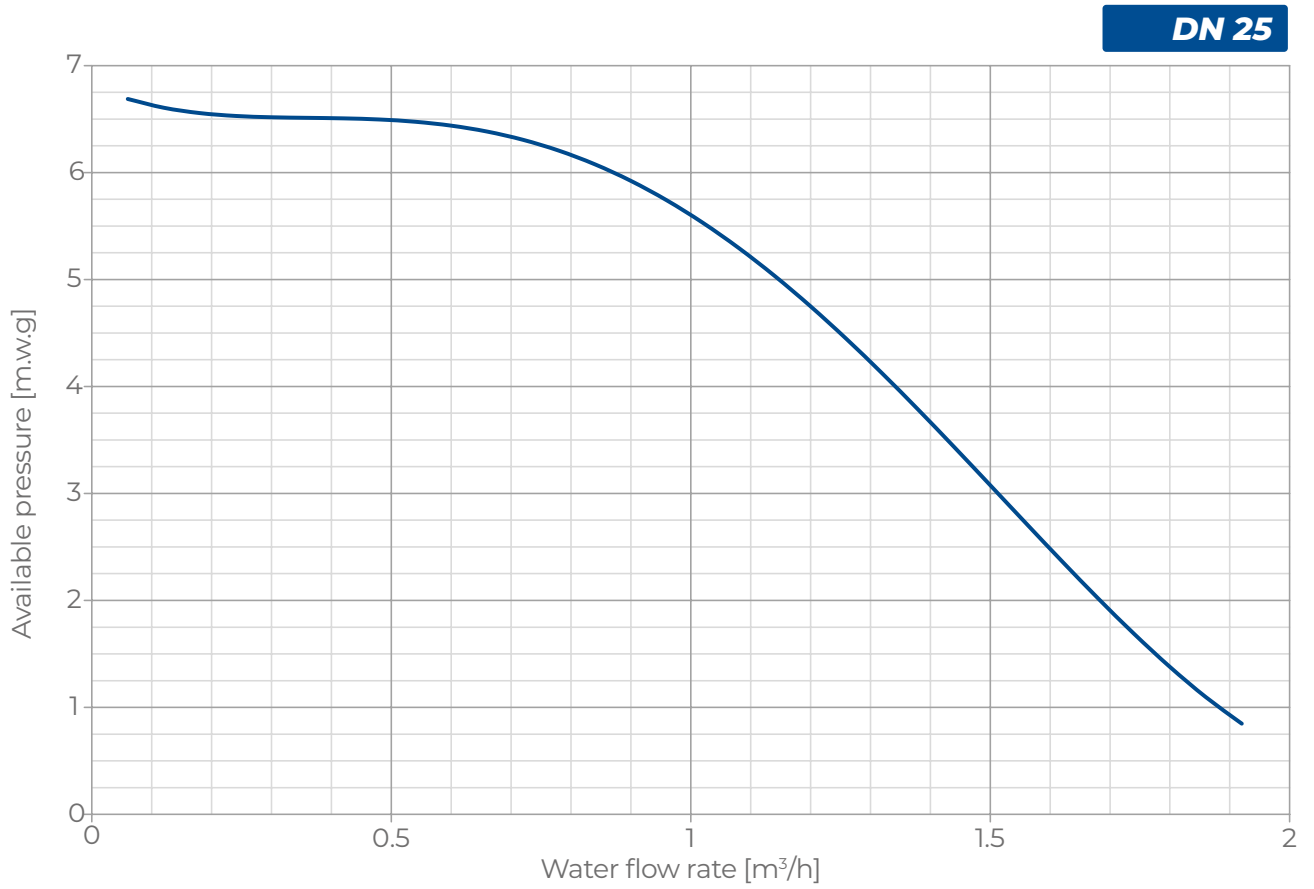

GM PF-CF MIXING UNIT



GM PF-CF mixing unit is a mixing unit for radiant systems. The supply water temperature is controlled by a mixing valve both in the winter and the summer modes managed through an electronic servo motor with dual regulation mode:

- climate regulation, external sensor for measuring the outdoor temperature included;
- electronic hot/cold fixed point regulation, with or without the use of the external sensor provided.

High-efficiency electronic circulator pump with variable flow rate and head. Complete with shut-off valves equipped with thermometers, PPE insulating cover and non-return valve with forced opening device. The CF Clima mixing unit can be installed also in the multiple version on a wall-mounted manifold.

FEATURES

- Electronic fixed point mixing valve
- Electronic circulator with variable flow rate and head
- Hydraulic connections \varnothing 1" M generator side and \varnothing 1" F system side (DN 25)
- Hydraulic connections \varnothing 1½" M generator side and \varnothing 1½" F system side (DN 32)
- Hydraulic connection centre distance: 125 mm
- Maximum temperature: 95 °C
- Maximum operating pressure: 8 bar
- Supply voltage: 230V - 50 Hz
- Water flow rate: 2000 l/h with 3.5 m.w.g. (DN 25)
- Water flow rate: 4000 l/h with 4 m.w.g. (DN 32)

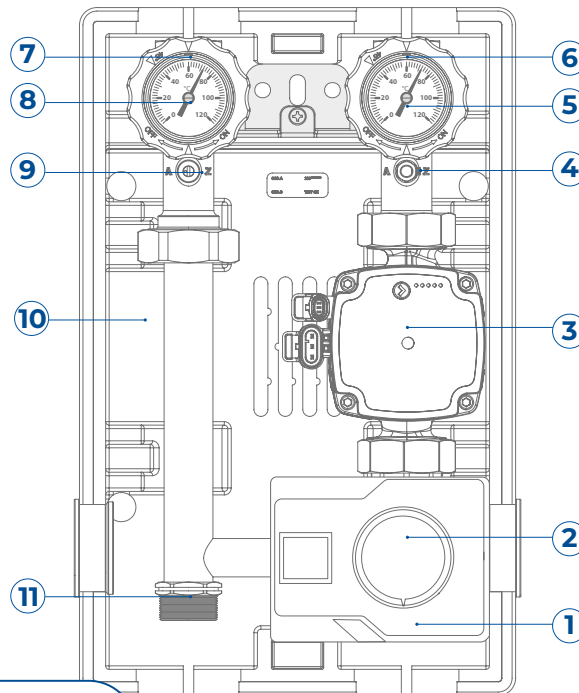

- 1 Water inlet from water production source
- 2 Mixing valve with hot/cold fixed point electronic servomotor
- 3 Circulator
- 4 Probe/safety thermostat holder
- 5 Supply water thermometer with ball valve
- 6 Water supply to the system
- 7 Water return from the system
- 8 Return thermometer with ball valve and non-return valve
- 9 Device for forcing normally open non-return valve
- 10 PPE insulating shell
- 11 Water return to water production source

DN	CODE
25	3800130
32	3800132

Technical data		Unit	GM PF DN 25	GM PF DN 32
Hydraulic circuit	Max Flow Rate	l/h	2000	4000
	Mixer Kvs		13	17
	Max Temperature	°C	95	
	Max Pressure	Bar	8	
	Liquid		Water / Water + glycol max 30%	
Electrical characteristic	Power supply voltage		230 V - 50 Hz	
	Max electrical absorption	W	63	151
Mechanical characteristics	Shut-off valves		DN 25	DN 32
	Generator side connections		1"	1" ¼
	System side connections		1"	1" ¼
	Distance between connections	mm	125	
	Dimensions l x h x p	mm	250x400x210	
	Weight	kg	5.4	5.7

Example
Thermoregulation with the use of GM PF-CF unit

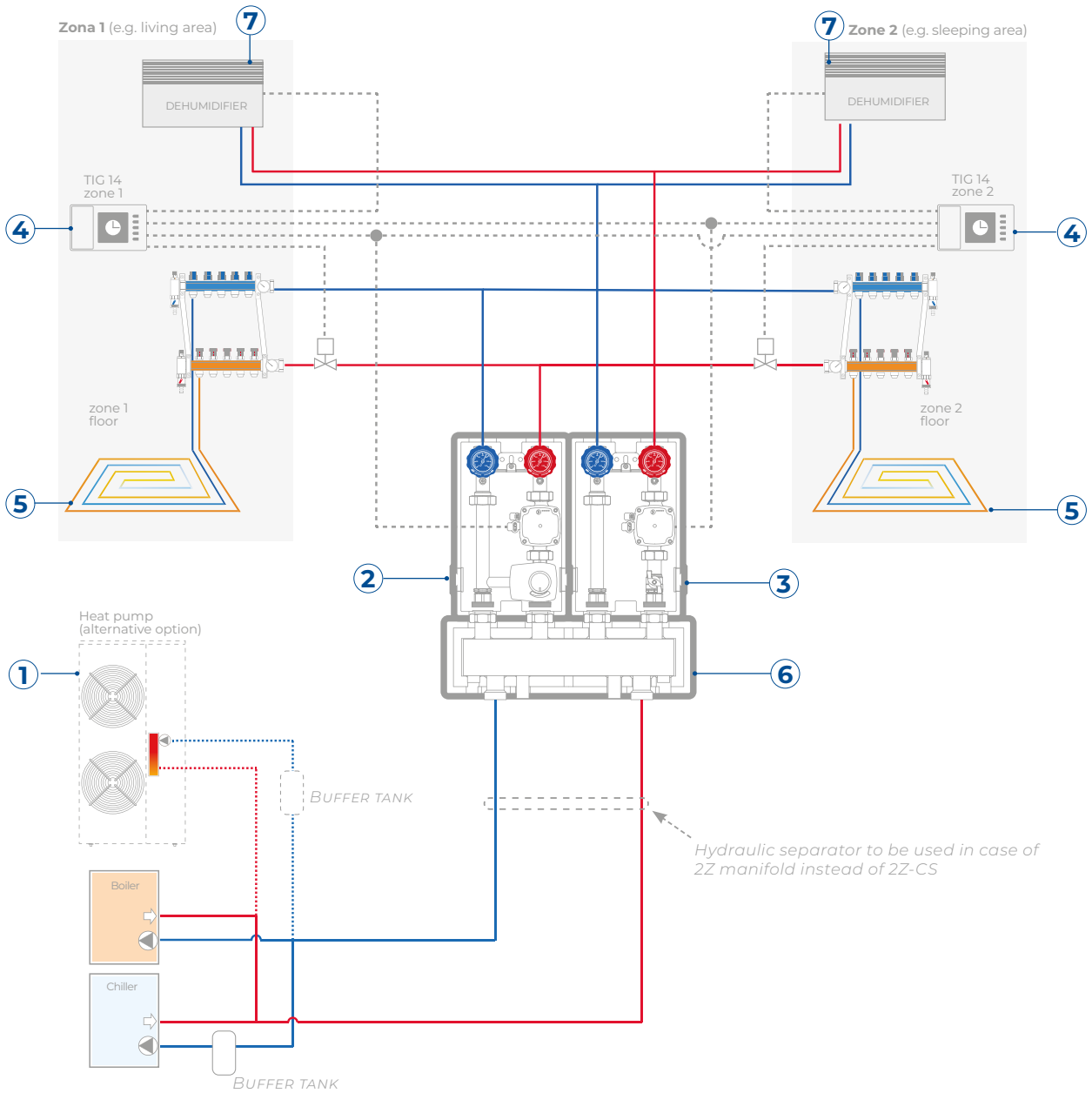

- 1 Air-water heat pump (as an alternative to chiller and boiler)
- 2 Mixing unit GM PF CF
- 3 Direct supply unit GR
- 4 Thermohumidistat TIG 14
- 5 Radiant underfloor or ceiling system
- 6 2Z-CS manifold
- 7 Dehumidifier mod. RNW

The proposed layout is indicative

■ HYDRAULIC PERFORMANCES

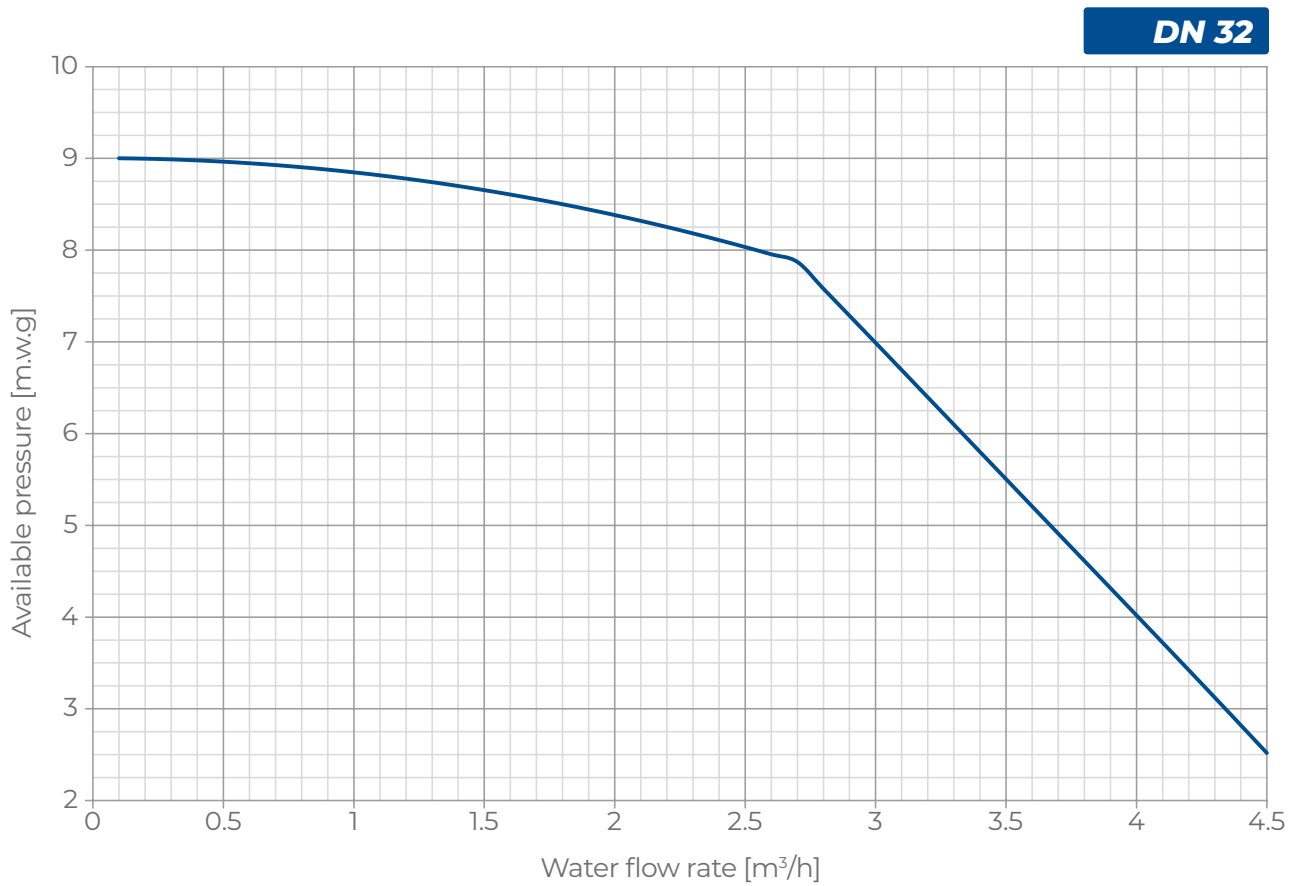
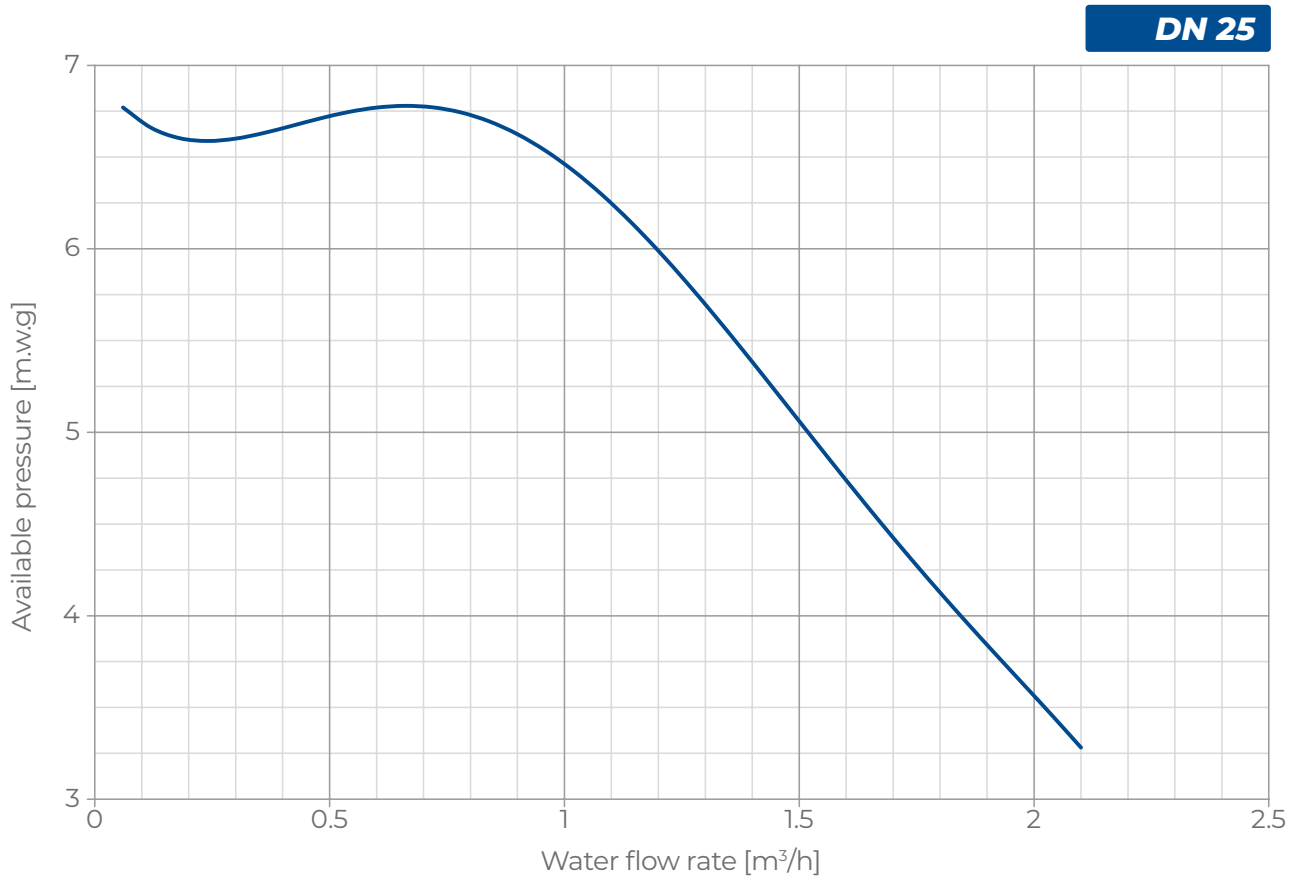



GM VJ mixing unit is a technical room device for the distribution of the thermovector fluid in radiant underfloor, ceiling and wall heating and cooling systems.

The supply temperature is regulated by a mixing valve controlled by a 24 V servomotor driven by 0-10 signal. Inside the unit there is a high-efficiency electronic circulator with variable flow rate and head that ensures low electrical consumption.

The unit is completed with two shut-off valves with thermometers respectively installed on the supply and return lines of the system, an insulating shell made of PPE and a non-return valve to prevent undesired circulation inside the systems with a forced-opening device.

The mixing unit can also be mounted in a multiple version on a wall-mounted manifold. GM VJ can be controlled with an external control unit mod. RDZ Wi or Trio Plus.

FEATURES

- Modulating mixing valve
- Servomotor with 0-10 to 24V signal
- Electronic circulator with variable flow rate and head
- Hydraulic connections \varnothing 1" M generator side and \varnothing 1" F system side (DN 25)
- Hydraulic connections \varnothing 1½" M generator side and \varnothing 1½" F system side (DN 32)
- Hydraulic connection centre distance: 125 mm
- Maximum temperature: 95 °C
- Maximum operating pressure: 8 bar
- Supply voltage: 230V - 50 Hz
- Water flow rate: 2000 l/h with 3.5 m.w.g. (DN 25)
- Water flow rate: 4000 l/h with 4 m.w.g. (DN 32)

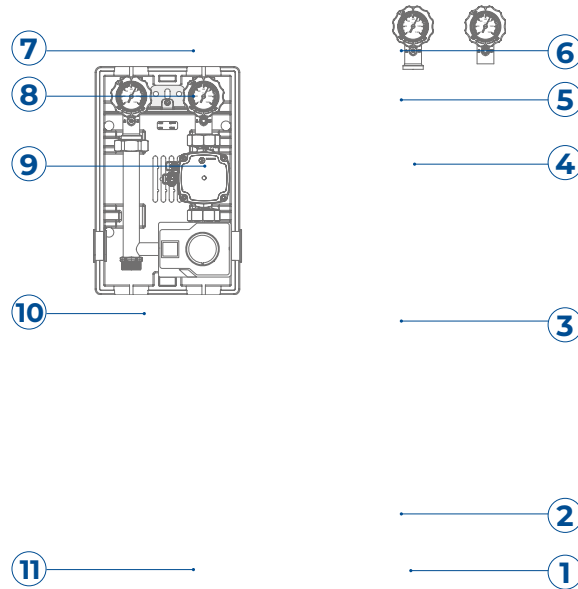

- 1 Water inlet from water production source
- 2 Mixer with 24V electronic servomotor and 0-10 V signal
- 3 Circulator
- 4 Probe/safety thermostat holder
- 5 Supply water thermometer with ball valve
- 6 Water supply to the system
- 7 Water return from the system
- 8 Return thermometer with ball valve and non-return valve
- 9 Device for forcing normally open non-return valve
- 10 PPE insulating shell
- 11 Water return to water production source

DN	CODE
25	3800110
32	3800140

Technical data		Unit	GM VJ DN 25	GM VJ DN 32
Hydraulic circuit	Max Flow Rate	l/h	2000	4000
	Mixer Kvs		13	17
	Max Temperature	°C	95	
	Max Pressure	Bar	8	
	Liquid		Water / Water + glycol max 30%	
Electrical characteristic	Power supply voltage		230 V – 50 Hz	
	Max electrical absorption	W	63	151
Mechanical characteristics	Shut-off valves		DN 25	DN 32
	Generator side connections		1"	1" ¼
	System side connections		1"	1" ¼
	Distance between connections	mm	125	
	Dimensions l x h x p	mm	250x400x210	
	Weight	kg	5.4	5.7

Example
Thermoregulation with the use of GM VJ unit

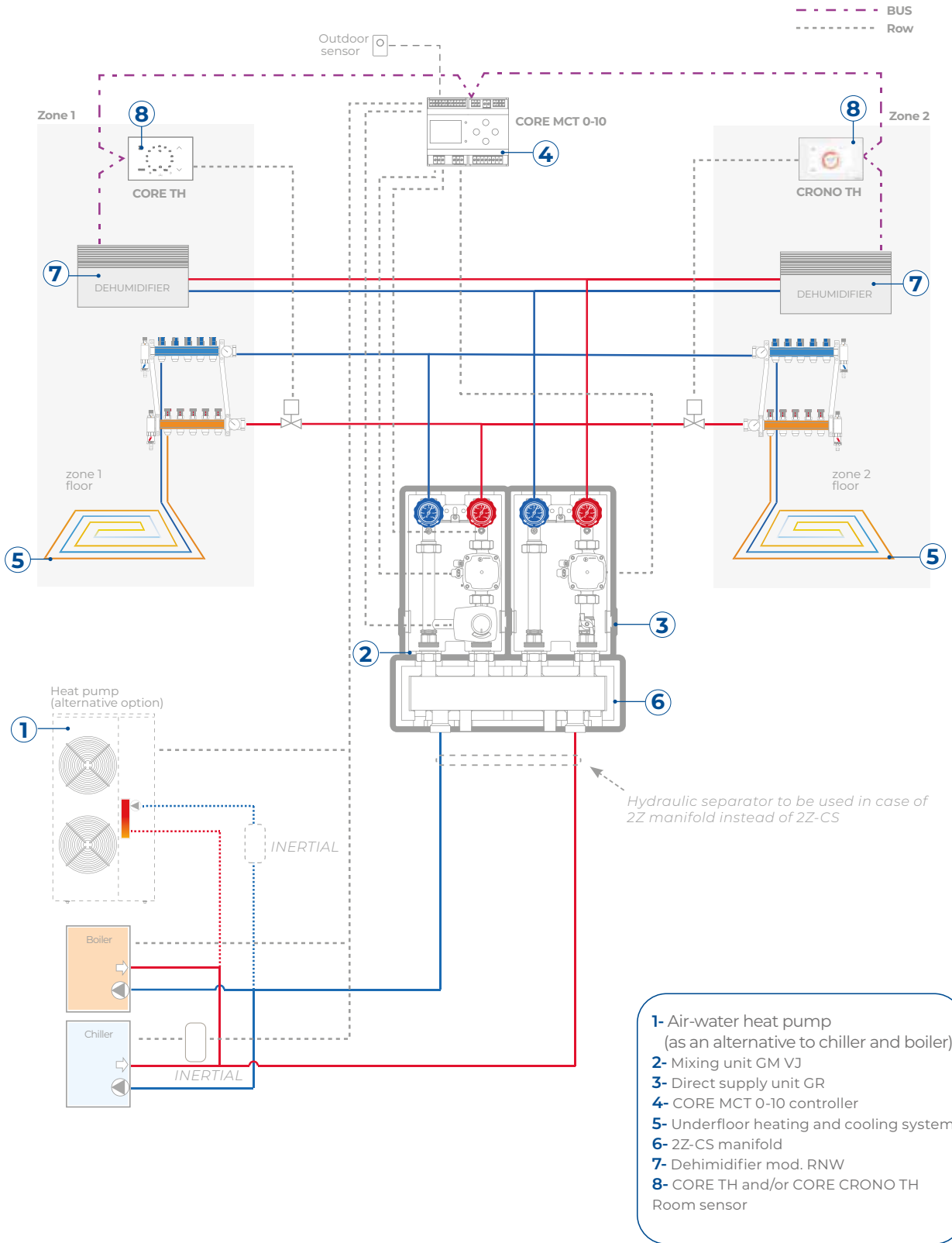

The proposed layout is indicative

■ HYDRAULIC PERFORMANCES

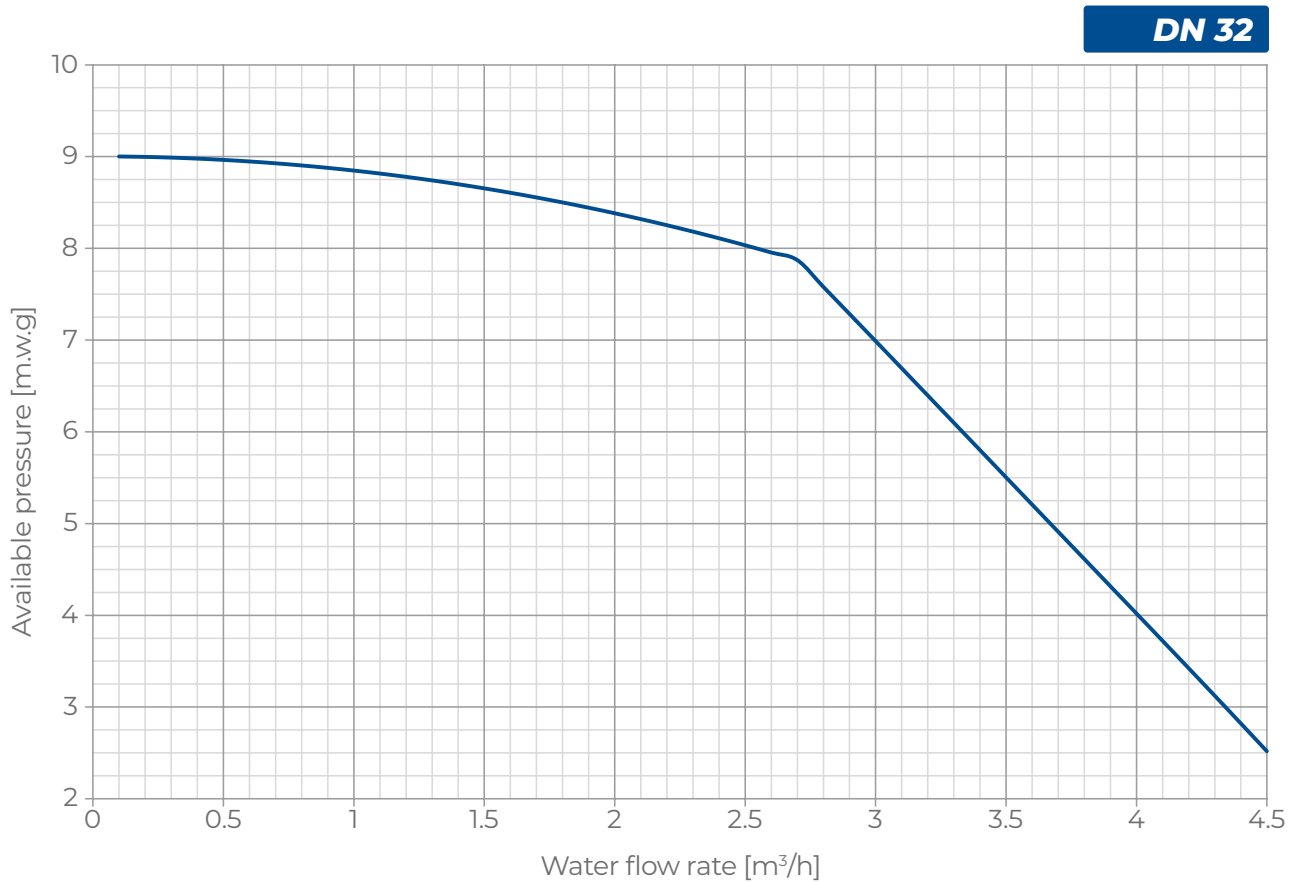
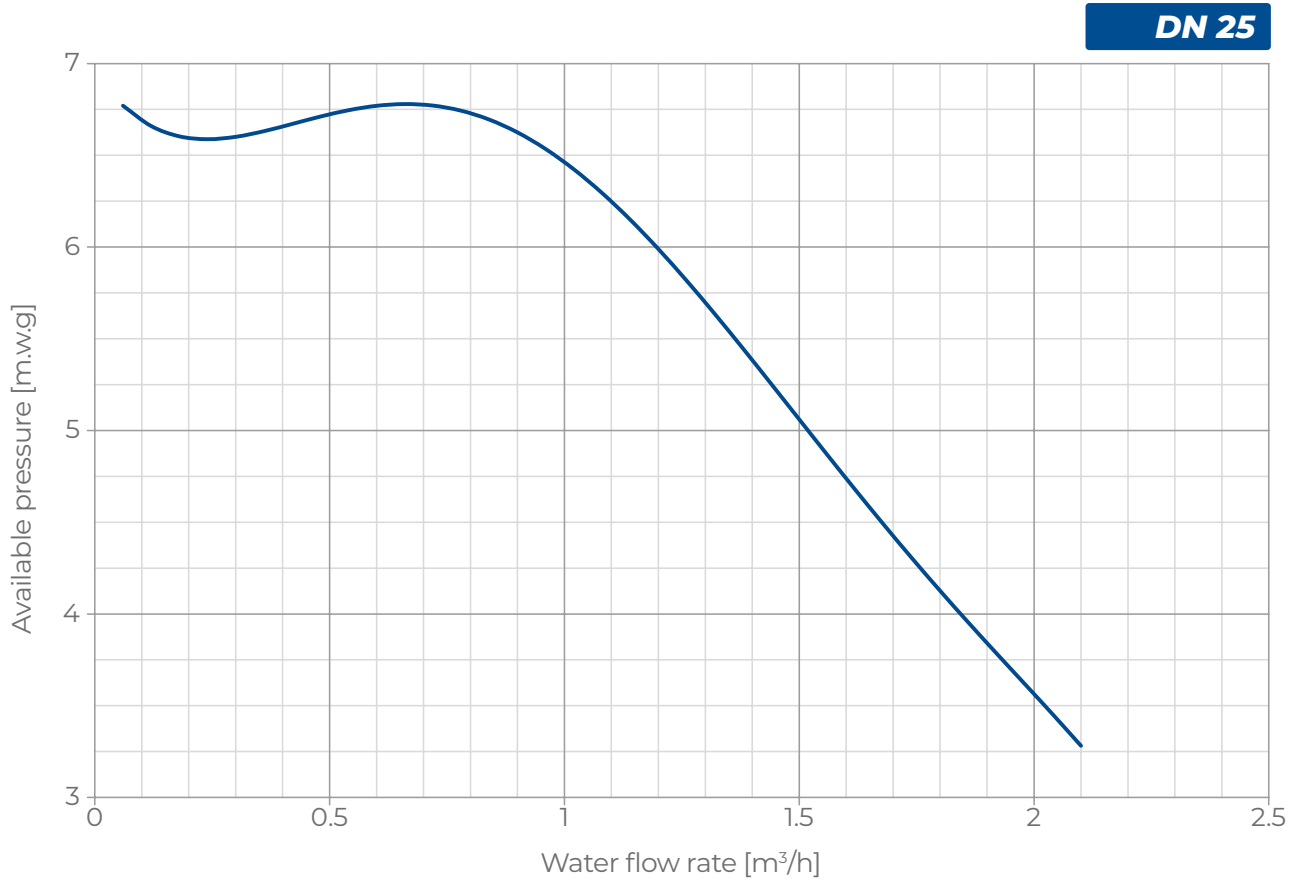

GM 3-POINT MIXING UNIT



GM 3-POINT mixing unit is a technical room device for distributing the thermovector fluid in radiant underfloor, ceiling and wall heating and cooling systems.

The flow temperature is regulated by a mixing valve controlled by a 230 V servomotor driven by 3-point signal. Inside the unit there is a high-efficiency electronic circulator with variable flow rate and head that ensures low power consumption.

The unit is completed with two shut-off valves with thermometers respectively installed on the system supply and return, an insulating shell in PPE and a non-return valve to prevent undesired circulation inside the systems with a forced-opening device.

The mixing unit can also be mounted in a multiple version on a wall-mounted manifold. GM 3 points can be controlled with external control unit mod. RDZ Easy Clima SA.

FEATURES

- 3-way mixing valve
- Servomotor with 230V 3-point signal
- Electronic circulator with variable flow rate and head
- Hydraulic connections Ø 1" M generator side and Ø 1" F system side
- Centre distance between hydraulic connections: 125 mm
- Maximum temperature: 95 °C
- Maximum operating pressure: 8 bar
- Supply voltage: 230V - 50 Hz
- Water flow rate: 1500 l/h with 4 m.w.g.

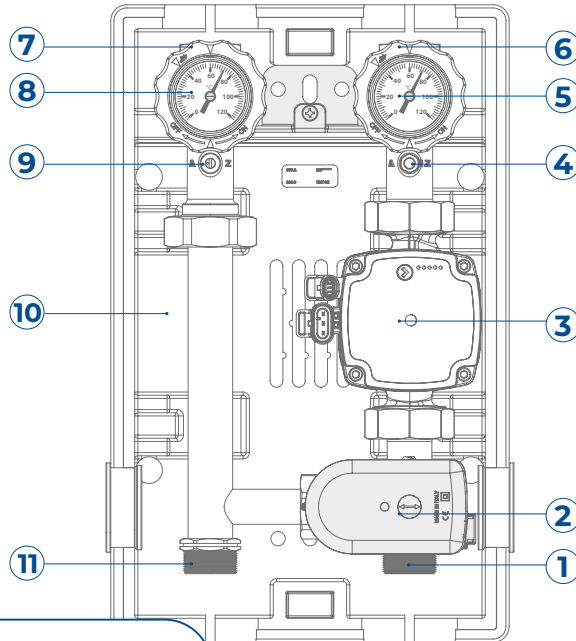

- 1 Water inlet from water production source
- 2 Mixer with 230 V servomotor and 3-point signal
- 3 Circulator
- 4 Probe/safety thermostat holder
- 5 Supply water thermometer with ball valve
- 6 Water supply to the system
- 7 Water return from the system
- 8 Return thermometer with ball valve and non-return valve
- 9 Device for forcing normally open non-return valve
- 10 PPE insulating shell
- 11 Water return to water production source

DN	CODE
25	3800112

Technical data		Unit	3-point
Hydraulic circuit	Max Flow Rate	l/h	1500
	Mixer Kvs		4,5
	Max Temperature	°C	95
	Max Pressure	Bar	8
	Liquid		Water / Water + glycol max 30%
Electrical characteristic	Power supply voltage		230 V – 50 Hz
	Max electrical absorption	W	63
Mechanical characteristics	Shut-off valves		DN 25
	Generator side connections		1"
	System side connections		1"
	Distance between connections	mm	125
	Dimensions l x h x p	mm	250x400x210
	Weight	kg	5,4

Example
Thermoregulation with the use of GM 3-point unit

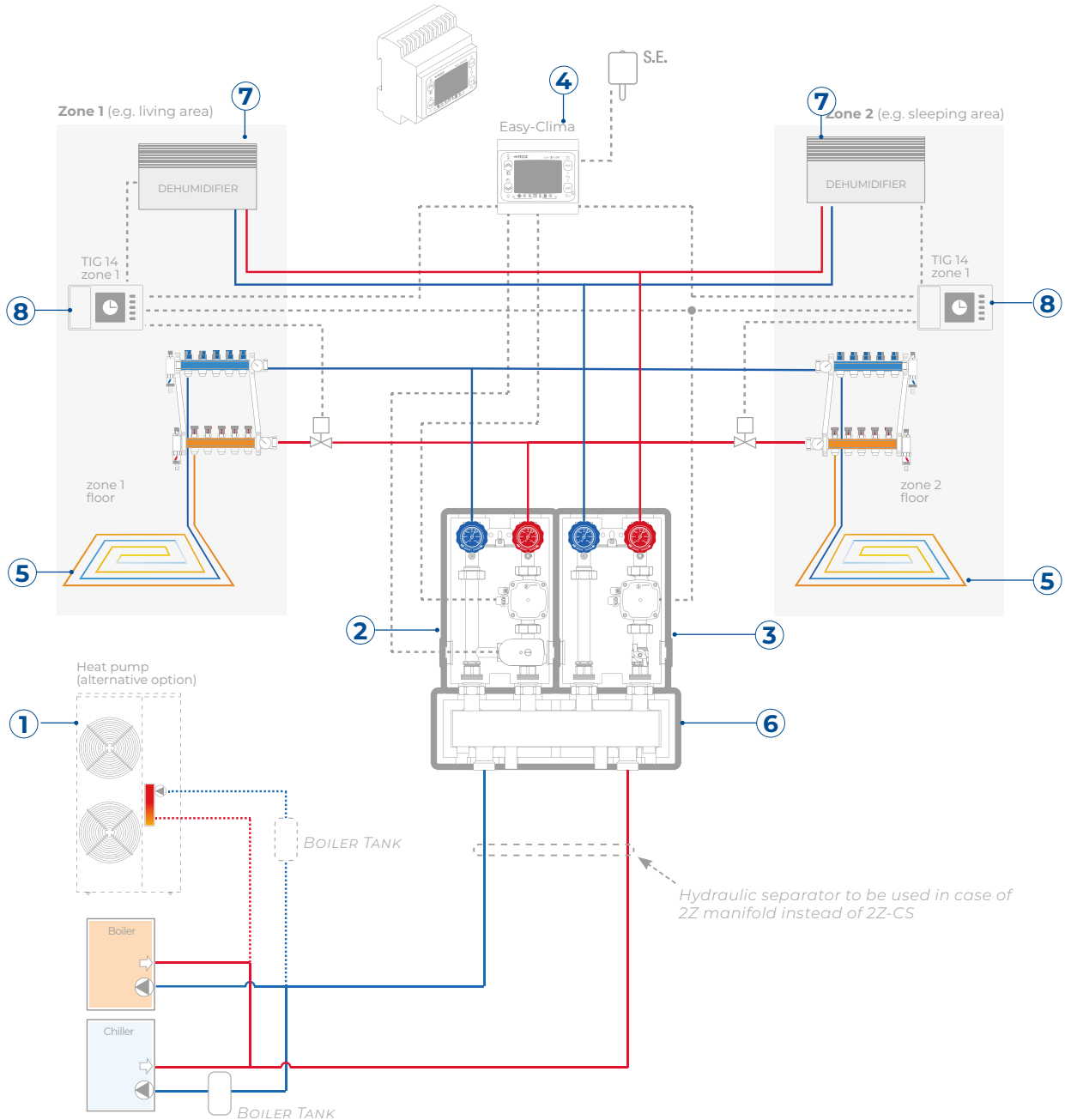

- 1 Air-water heat pump (as an alternative to chiller and boiler)
- 2 Mixing unit GM 3
- 3 Direct supply unit GR
- 4 Easy-Clima SA controller
- 5 Floor heating and cooling system
- 6 2Z-CS manifold
- 7 Dehumidifier mod. RNW
- 8 Thermohumidistat TIG 14

The proposed layout is indicative

■ HYDRAULIC PERFORMANCES

DN 25

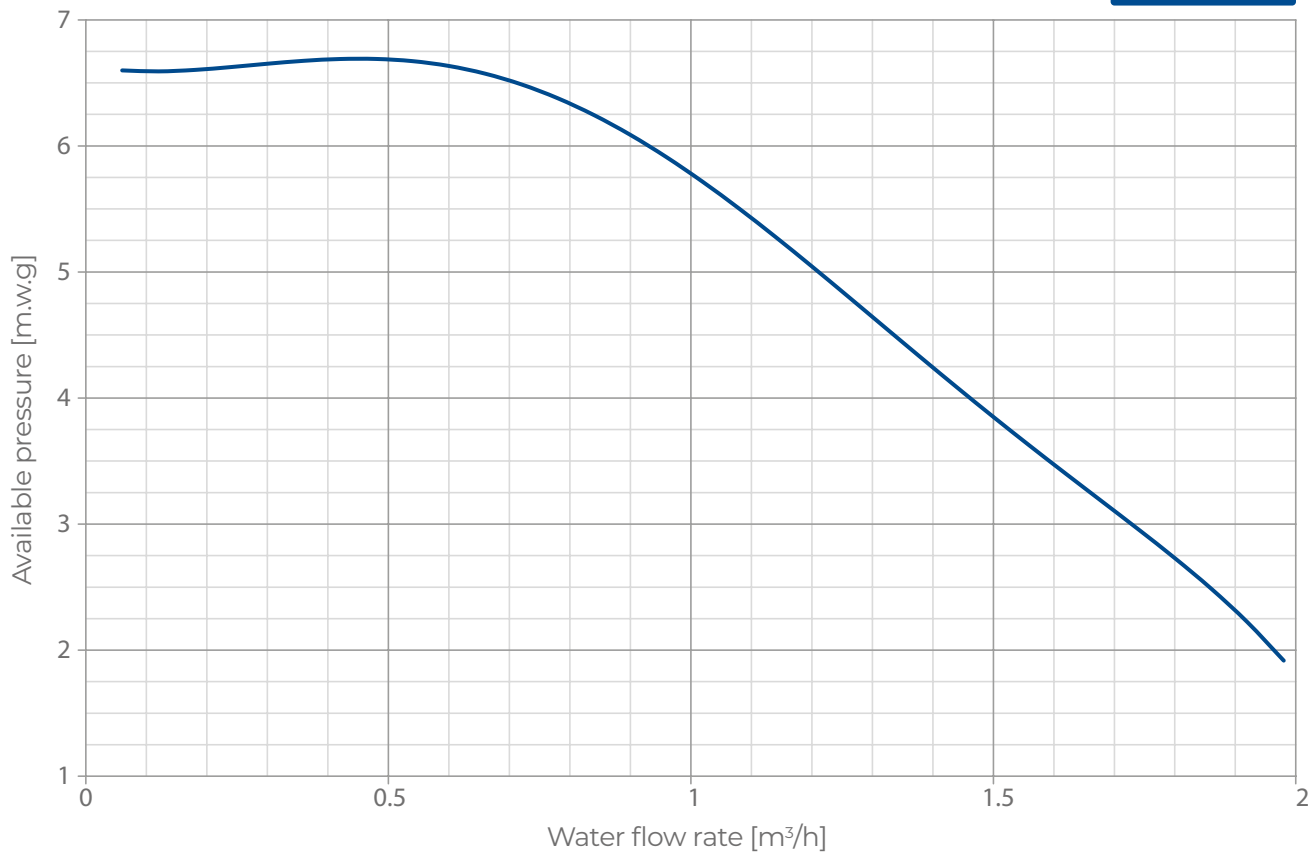



GR direct supply unit is a technical room device for direct non-mixed water supply to manage high temperature systems and dehumidifiers.

The unit features a high-efficiency electronic circulator with variable flow rate and head that ensures low power consumption.

The unit is completed with two shut-off valves with thermometers respectively installed on the supply and return lines of the system, with an insulating shell in EPP and with a non-return valve to prevent undesired circulation inside the systems with a forced-opening device.

FEATURES

- Shut-off ball valve
- Electronic circulator with variable flow rate and head
- Hydraulic connections \varnothing 1" M generator side and \varnothing 1" F system side
- Hydraulic connection centre distance: 125 mm
- Maximum temperature: 95 °C
- Maximum operating pressure: 8 bar
- Supply voltage: 230V - 50 Hz
- Water flow rate: 2000 l/h with 3.5 m.w.g. (DN 25)
- Water flow rate: 4000 l/h with 4.0 m.w.g. (DN 32)

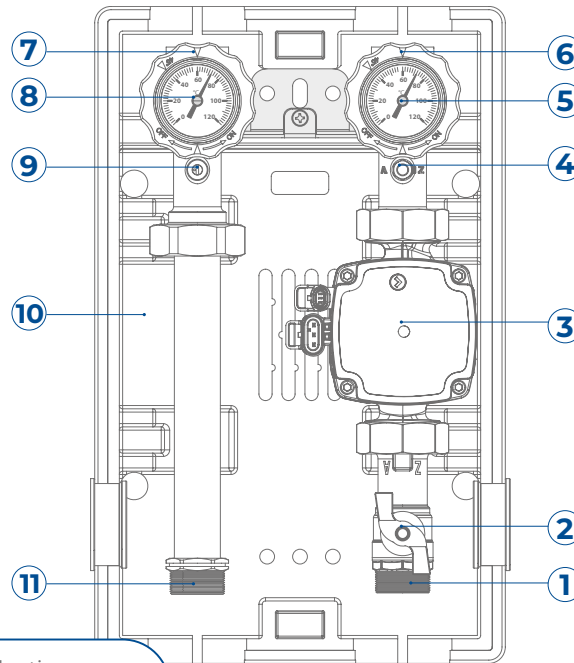

- 1 Water inlet from water production source
- 2 Shut-off ball valve
- 3 Circulator
- 4 Probe/safety thermostat holder
- 5 Supply water thermometer with ball valve
- 6 Water supply to the system
- 7 Water return from the system
- 8 Return thermometer with ball valve and non-return valve
- 9 Device for forcing normally open non-return valve
- 10 PPE insulating shell
- 11 Water return to water heating source

DN	CODE
25	3800100
32	3800105

Technical data		Unit	GR DN 25	GR DN 32
Hydraulic circuit	Max Flow Rate	l/h	2400	4000
	Mixer Kvs		/	/
	Max Temperature	°C	95	
	Max Pressure	Bar	8	
	Liquid		Water / Water + glycol max 30%	
Electrical characteristic	Power supply voltage		230 V – 50 Hz	
	Max electrical absorption	W	63	151
Mechanical characteristics	Shut-off valves		DN 25	DN 32
	Generator side connections		1"	1" ¼
	System side connections		1"	1" ¼
	Distance between connections	mm	125	
	Dimensions l x h x p	mm	250x400x210	
	Weight	kg	5.4	5.7

HYDRAULIC PERFORMANCES

DN 25

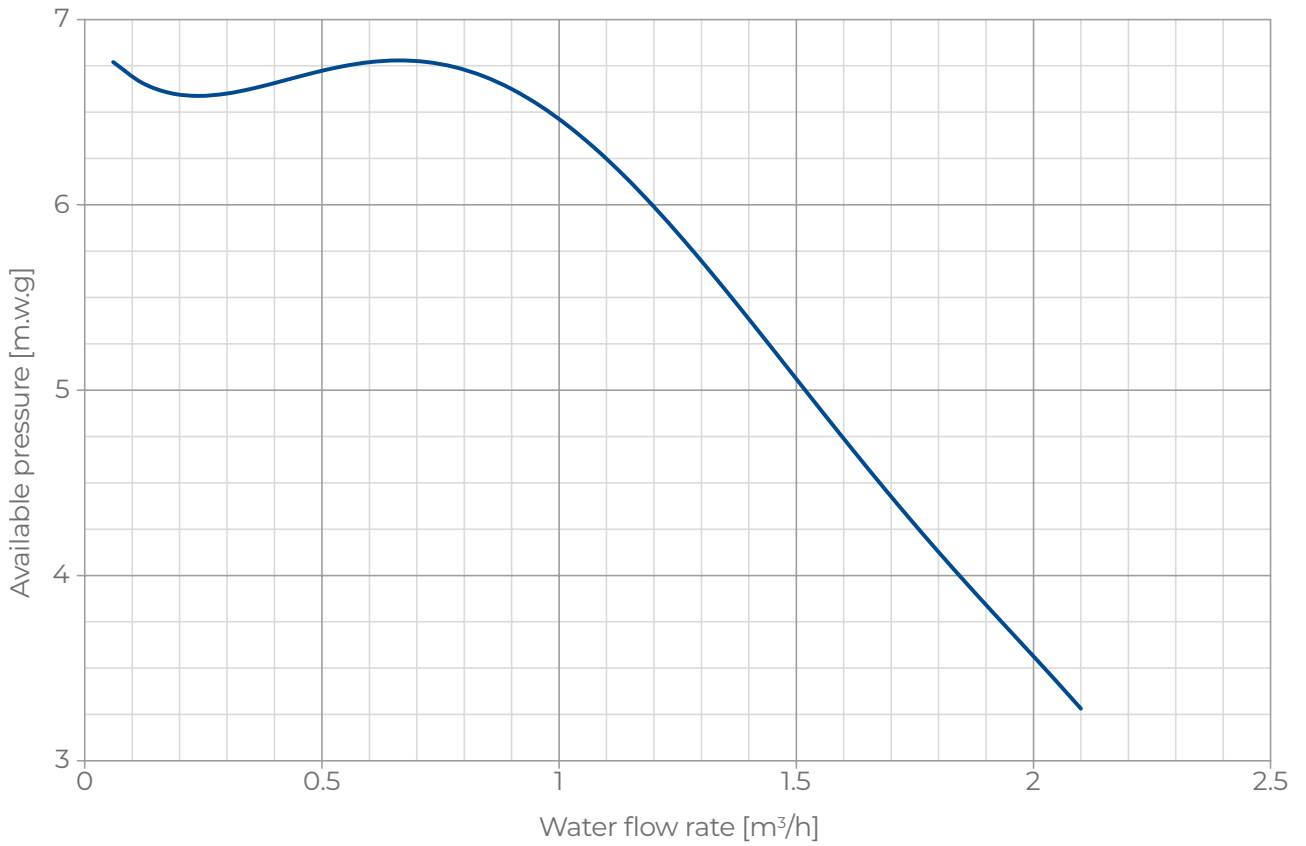

DN 32

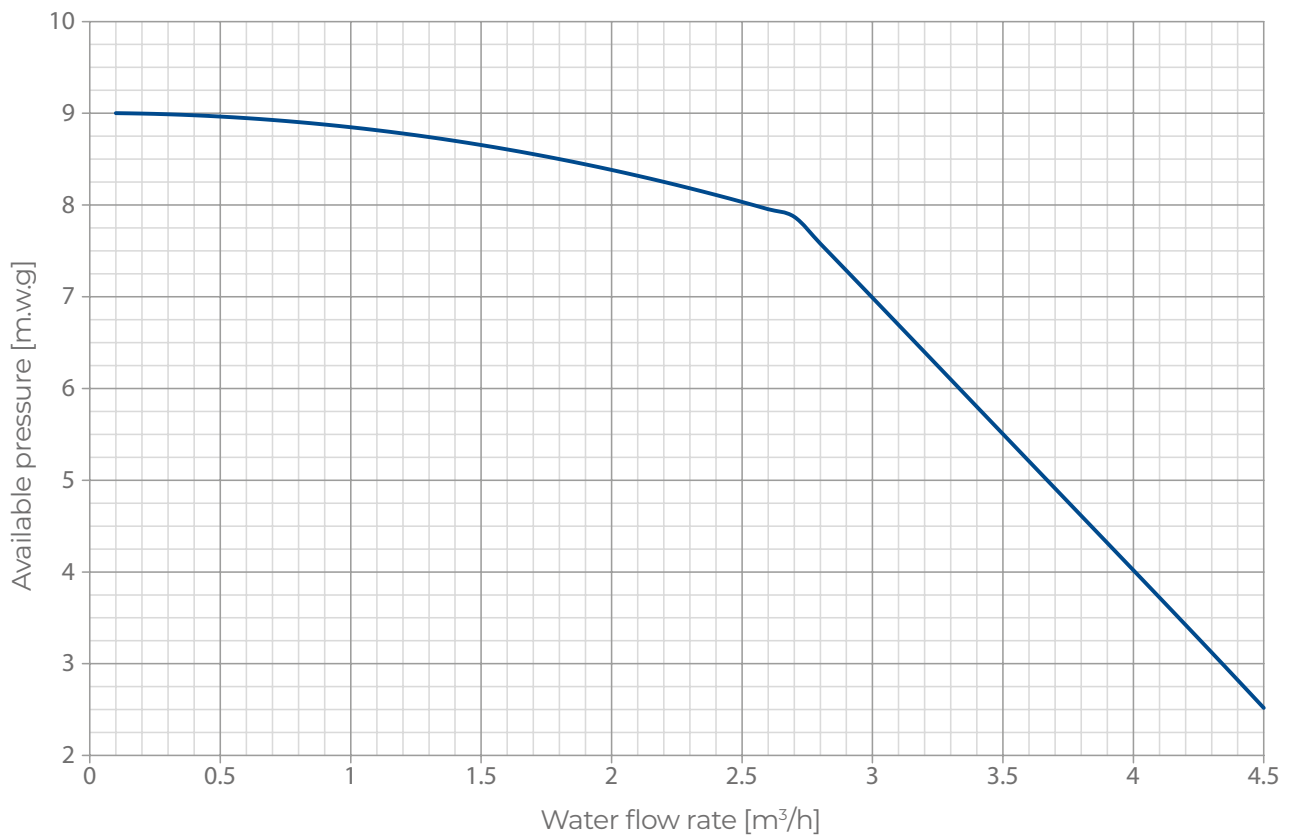

■ ■ ACCESSORIES FOR GM AND GR UNITS

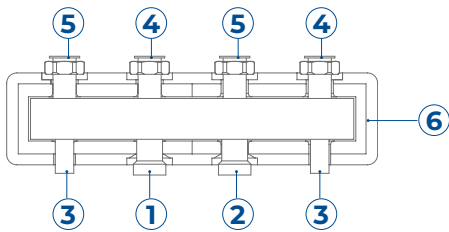

- 1 Water inlet from water production source M 1 1/2"
- 2 Water outlet to water production source M 1 1/2"
- 3 Wall mounting plug
- 4 System water supply F 1 1/2"
- 5 System water return F 1 1/2"
- 6 Insulating shell

Z Manifolds

Distribution manifolds for GM mixing units and/or GR direct supply unit. Their easy installation helps the arrangement of the boiler room. They shall be used if there is a tank acting as hydraulic separator. The manifold consists in a steel body with Ø 1"1/2 M hydraulic connections on the boiler side and 1"1/2 F on the system side. The heat generator is connected to the bottom, whereas 2 hydraulic units can be connected to the secondary circuit on the top through specific adapters. The manifold is equipped with PPE insulating shell to prevent condensation and minimise heat loss. Brackets and gaskets are supplied as standard. Connection adapters for GM and GR units shall be purchased separately.

- Max water flow-rate: 4500 l/h
- Max power: (ΔT 15 K): 78 kW

MODEL	OUTLETS	SIZE LXHXP	CODE
2Z	2	545x175x170 mm	3800522
3Z	3	795x175x170 mm	3800523
4Z	4	1045x175x170 mm	3800524

Caution: the inlets and outlets on the central heating side on 3Z manifolds must be inverted with respect to the other 2 models.

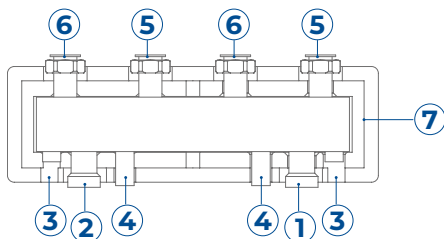

- 1 Water inlet from water production source M 1 1/2"
- 2 Water outlet to water production source M 1 1/2"
- 3 Connections for installation of sensors and filling/drainage tap F 1/2"
- 4 Wall mounting plugs
- 5 System water supply F 1 1/2"
- 6 System water return F 1 1/2"
- 7 Insulating shell

Z-CS Manifold

Distribution manifolds for GM mixing units and/or GR direct supply unit, provided with the hydraulic separator. Their easy installation helps the arrangement of the boiler room. The unit can be connected directly with the boiler or with the chiller if they are equipped with their own circulation pump. The manifold consists in a steel body with Ø 1" 1/2 M hydraulic connections on the boiler side and 1" 1/2 F on the system side. The heat generator is connected to the bottom, whereas 2 hydraulic units can be connected to the secondary circuit on the top through specific adapters. The manifold is equipped with PPE insulating shell to prevent condensation and minimise heat loss. Brackets and gaskets are supplied as standard. Connection adapters for GM and GR units shall be purchased separately.

- Max water flow-rate: 4500 l/h
- Max power: (ΔT 15 K): 78 kW

MODEL	OUTLETS	SIZE LXHXP	CODE
2Z-CS	2	545x195x170 mm	3800504
3Z-CS	3	795x195x170 mm	3800505
4Z-CS	4	1045x195x170 mm	3800506

Example

System with 2Z collector and water taken from technical storage tank

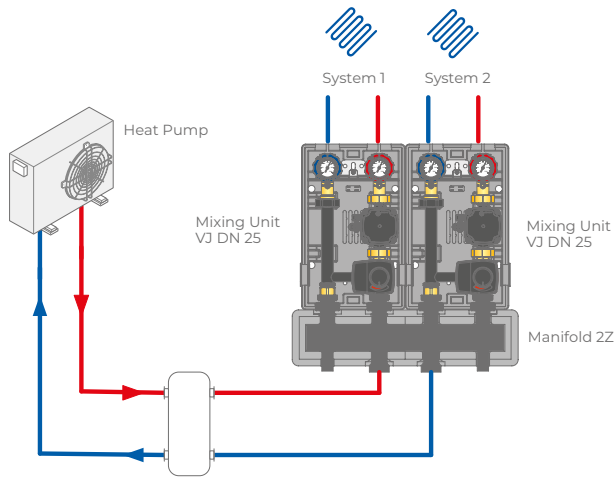

System example with 2Z-CS manifold and water directly supplied from heat pump

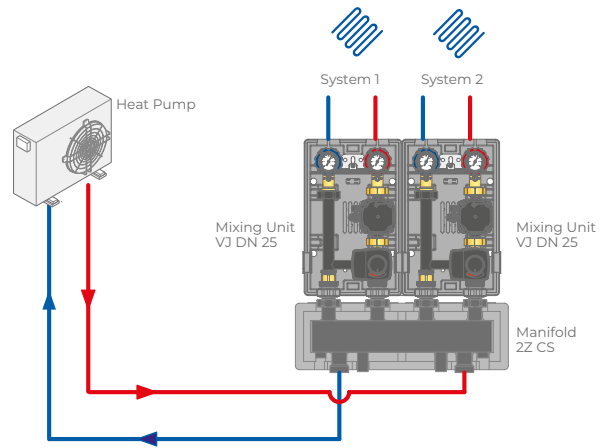

The proposed layouts are only indicative



Adapters

Pair of adapters for the hydraulic connection between mixing unit or direct supply unit and central distribution manifolds mod. Z and Z-CS.

MODEL	CODE
DN 25	3800525
DN 32	3800530

OPTIONAL FOR GM AND GR UNITS



Safety thermostat

Safety contact thermostat to set the maximum water temperature for GM mixing units and GR direct supply unit. The pump blocks if water supply temperature exceeds the set value.

CODE
3800902



Mixing Box is a thermoregulation device for radiant heating and cooling underfloor systems.

In particular, it is a hydraulic substation composed by a series of modules that mix and relaunch the thermovector fluid towards the emitting devices, including radiant underfloor systems, dehumidification units, air handling units and hydronic post-treatment batteries.

The direct supply units (GR), mixing units with thermostatic fixed point valve (PF) or mixing units with electronic mixing valve (VJ) are available in different combination in order to satisfy the multiple needs, and are inserted in a painted steel cabinet, available for recessed or wall installation. The mixing box is completed by an hydraulic separator with automatic vent valve, switchboard for electrical connections, thermal and anti-condensation shell, supply and return thermometers, high efficiency circulation pumps, thermostatic mixing valves (heating only) or 0-10V mixing valves for only heating or heating/cooling systems.

FEATURES

- Available in multiple configurations of directly supply units, fixed point mixing units and electronic modulation mixing units, in order to satisfy several needs
- Hydraulic connections (DN 15), Ø 3/4" M boiler side, Ø 3/4" F system side
- Hydraulic connections centre distance: 70 mm
- Kv hydraulic separator on water production side: 6.7 (2900 l/h with 2 m w.g. pressure drop)
- Water flow rate GR: 2100 l/h with 2 m w.g. of available pressure
- Water flow rate PF: 1300 l/h with 2 m w.g. of available pressure
- Water flow rate VJ: 1900 l/h with 2 m w.g. of available pressure
- Cabinet dimensions: 450x500x160 mm



Components

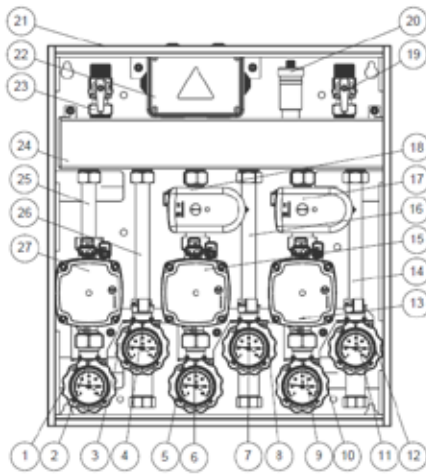

- 1 Supply valve 1
- 2 Probe holder supply 1
- 3 Return valve 1
- 4 Probe holder return 1
- 5 Supply valve 2
- 6 Probe holder supply 2
- 7 Return valve 2
- 8 Probe holder return 2
- 9 Supply valve 3
- 10 Probe holder supply 3
- 11 Return valve 3
- 12 Probe holder return 3
- 13 Pump for zone 3
- 14 Return pipe zone 3
- 15 Pump for zone 2
- 16 Return pipe zone 2
- 17 Mixing valve zone 3*
- 18 Mixing valve zone 2*
- 19 Return valve for primary circuit
- 20 Air vent valve
- 21 Steel cabinet
- 22 Switchboard
- 23 Supply valve for primary circuit
- 24 Hydraulic separator
- 25 Supply pipe zone 1
- 26 Return pipe zone 1
- 27 Pump for zone 1

*If present, it can be electric or thermostatic, basing on the model

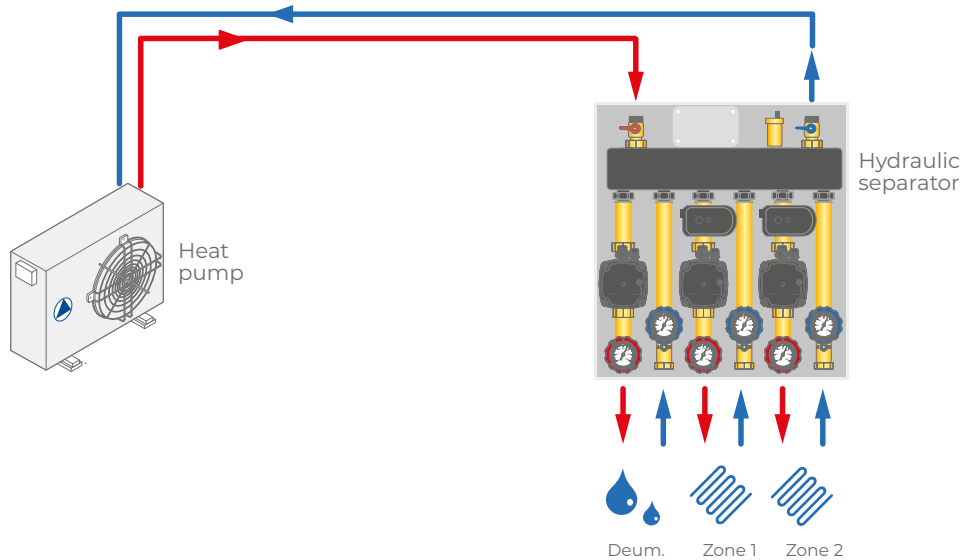

Example
Hydronic connections



MIXING BOX GR - PF - VJ

model	dimensions l x h x p (cm)	weight (kg)	code
1 GR - 1 PF	450x500x160	17.0	380GRPF00
2 GR - 1 PF	450x500x160	20.4	380GRGRPF
1 GR - 2 PF	450x500x160	20.6	380GRPFPF
2 PF	450x500x160	17.2	380PFPF00
3 PF	450x500x160	20.8	380PFPFPF
1 GR - 1 VJ	450x500x160	17.1	380GRVJ00
2 GR - 1 VJ	450x500x160	20.5	380GRGRVJ
1 GR - 2 VJ	450x500x160	20.8	380GRVJVJ
2 VJ	450x500x160	17.4	380VJVJ00
3 VJ	450x500x160	21.1	380VJVJVJ
2 GR	450x500x160	16.8	380GRGR00
3 GR	450x500x160	20.2	380GRGRGR

THERMOREGULATION DEVICES

Technical data	General features	GR Direct Supply Unit	PF Thermostatic Mixing Unit	VJ Electronic Mixing Unit
Circulation pump		GRUNDFOS UPM3 Hybrid 15-7 130mm - 1" Erp Ready		
Available pressure		7 mt		
Control		* PWM - PP - CP - CC - AA		
Max. temperature		95 °C continuous - 110° peak		
Power supply		230V / 50 Hz		
Max. power consumption		52 W		
Mixing valve		/	VTA 352	NVC3
Control		/	Thermostatic	0-10
kWs		/	2,3	3,6
Regulation range		/	20 °C - 55 °C	/
Power supply		/	/	24V ac/dc
Max. power consumption		/	/	5 W
IP class		/	/	IP 40
Hydraulic separator	NVS01			
Max. number of zones	3			
Connections	3/4" M - DN20			
Section	4.000 mm ² - DN 50			
Volume	1,5 lt			
Max. ΔT zone supply	± 2 °C			
Max. pressure	6 bar			
Material	Fe 58			
Finishing	Black painted			
Max. water supply		***2.100 lt/h	***1.300 lt/h	***1.900 lt/h
Max. temperature		95 °C continuous - 110 °C peak		
Min. temperature		5 °C		
Max. pressure		**4,5 bar - 3 bar with security valve on water production side		
Available pressure at 1000 lt/h		6,4 m w.g.	3,8 m w.g.	6,2 m w.g.
Power exchanged at ΔT 5°C		***10 kW	***7 kW	***10 kW
Power exchanged at ΔT 10°C		***20 kW	***14 kW	***20 kW
Power exchanged at ΔT 15°C		***30 kW	/	/
Power exchanged at ΔT 20°C		***35 kW	/	/
Fluid		Water		
One-way valve		√	√	√
P non-return valve opening		ΔP: 2kPa (200 mm w.g.)		
Thermometer calibration range		0 °C - 120 °C		
IP protection	IPX 0	/		
Finishing	White painted	/		
Size		DN 15		
Boiler side connections	3/4" M			
System side connections		3/4" F		
Centre distance		70 mm	70 mm	70 mm
External dimensions	450x500x160			
Empty weight	10 kg	3,4 kg	3,6 kg	3,7 kg
Water content	1,5 lt	0,3 lt	0,3 lt	0,3 lt
Conformity	Product compliant to: EN 16297-2 / EN 16297-3: 2012 Erp Ready Direttiva PED-2014/68/UE			 
<p>* PWM : external control via PWM, profilo A or C mode PP: Proportional Pressure - CP: Costant Pressure - CC: Constant Curve - AA: AUTOADAPT ** Check the calibration of the security valve on water production and/or sytem side *** With residual head of 2 m w.g.</p>				

MIXING BOX PERFORMANCES

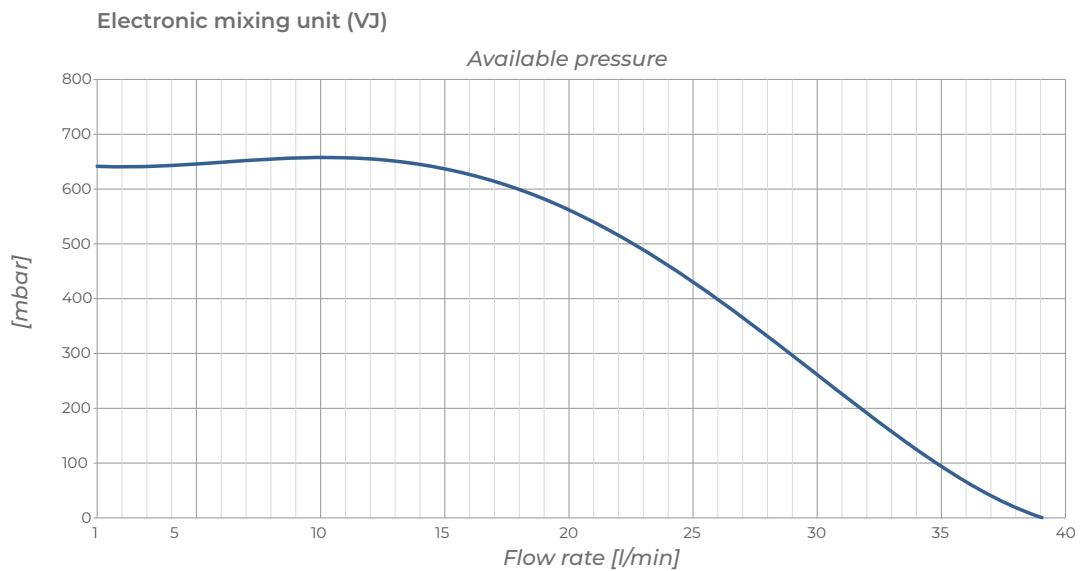
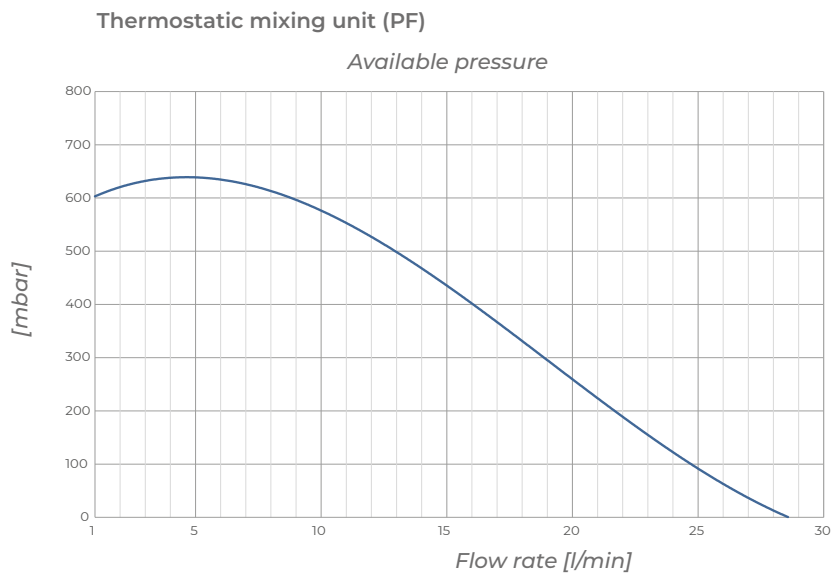
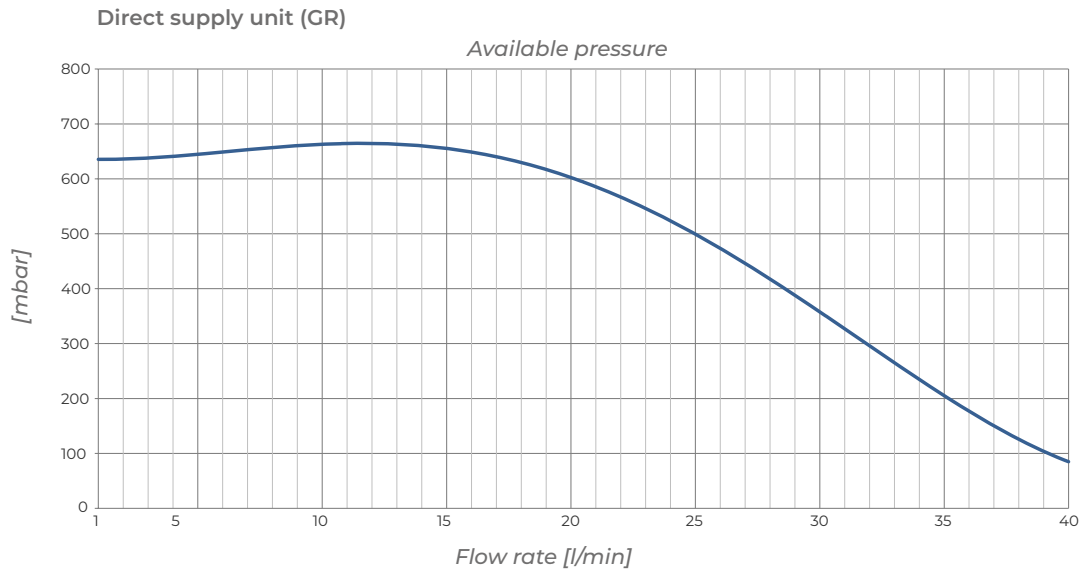

PF THERMOREGULATION KIT



The Kit is a device that includes in a single product, suitable for installation in room, the radiant distribution part (underfloor system), temperature control and high temperature outlets for connecting up to 3 radiators. The **PF** version, in particular, is suitable for managing heating only.

It is complete with zinc-plated steel cabinet with adjustable feets, brackets, protective cover for plaster, white door with lock, adjustable frame, water production-side by-pass, a 3-way mixing valve with thermostatic control and adjustment range up to 50 °C (heating only), electronic circulator, a micrometric lockshield, one-way valve, shut-off valves, thermometers, air trap, balancing lockshield, vent valve and fill/drain valves, connector to the electrical installation, and wired system. Optionally, the kit can be equipped with 2 or 3 high temperature outlets and a control box with safety devices.

The kit is available with CONTROL series brass manifolds or TOP COMPOSIT series technopolymer manifolds.

FEATURES

- Suitable for connection to water production source with built-in pump
- Control with 3-way mixing valve
- Adjustable thermostatic valve with bulb and capillary
- High efficiency electronic circulator
- Electrical wiring with IP 43 protection
- Air separator
- Electronic safety thermostat (optional)
- Controllable high temperature outlets for radiators (optional)



- A Fill/drain traps
- B Return manifold
- C Return thermometer
- D Thermostatic element
- E Control unit
- F Mixing valve
- G Pump
- H Adjustment feet
- I Balancing lockshield
- L Supply thermometer
- M Supply manifold
- N Cabinet
- O Adapter for pipe Ø 17
- P Terminal unit
- Q 2 outlets HT manifold
- R 3 outlets HT manifold
- S 3-way air trap
- T PF control board

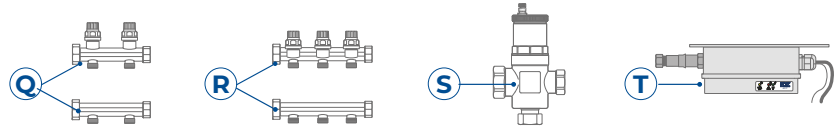
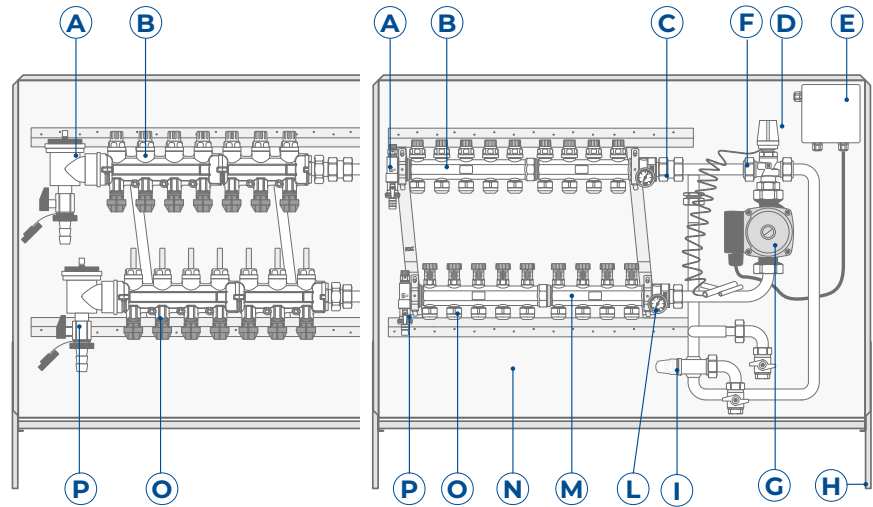

PF Kit with Top Composit manifold

n. outlets	dimensions l x h x p (cm)	code Ø 17
3+3	65x83÷89x14.5	3PP03N0BN7
4+4	65x83÷89x14.5	3PP04N0BN7
5+5	65x83÷89x14.5	3PP05N0BN7
6+6	80x83÷89x14.5	3PP06N0BN7
7+7	80x83÷89x14.5	3PP07N0BN7
8+8	80x83÷89x14.5	3PP08N0BN7
9+9	100x83÷89x14.5	3PP09N0BN7
10+10	100x83÷89x14.5	3PP10N0BN7
11+11	100x83÷89x14.5	3PP11N0BN7
12+12	100x83÷89x14.5	3PP12N0BN7

PF Kit with Control manifold

n. outlets	dimensions l x h x p (cm)	code Ø 17
3+3	65x83÷89x14.5	3PO03N0BN7
4+4	65x83÷89x14.5	3PO04N0BN7
5+5	65x83÷89x14.5	3PO05N0BN7
6+6	80x83÷89x14.5	3PO06N0BN7
7+7	80x83÷89x14.5	3PO07N0BN7
8+8	80x83÷89x14.5	3PO08N0BN7
9+9	100x83÷89x14.5	3PO09N0BN7
10+10	100x83÷89x14.5	3PO10N0BN7
11+11	100x83÷89x14.5	3PO11N0BN7
12+12	100x83÷89x14.5	3PO12N0BN7

FOR COMPLETE CODING REFER TO PAGE 221

Example
Thermoregulation with PF kit

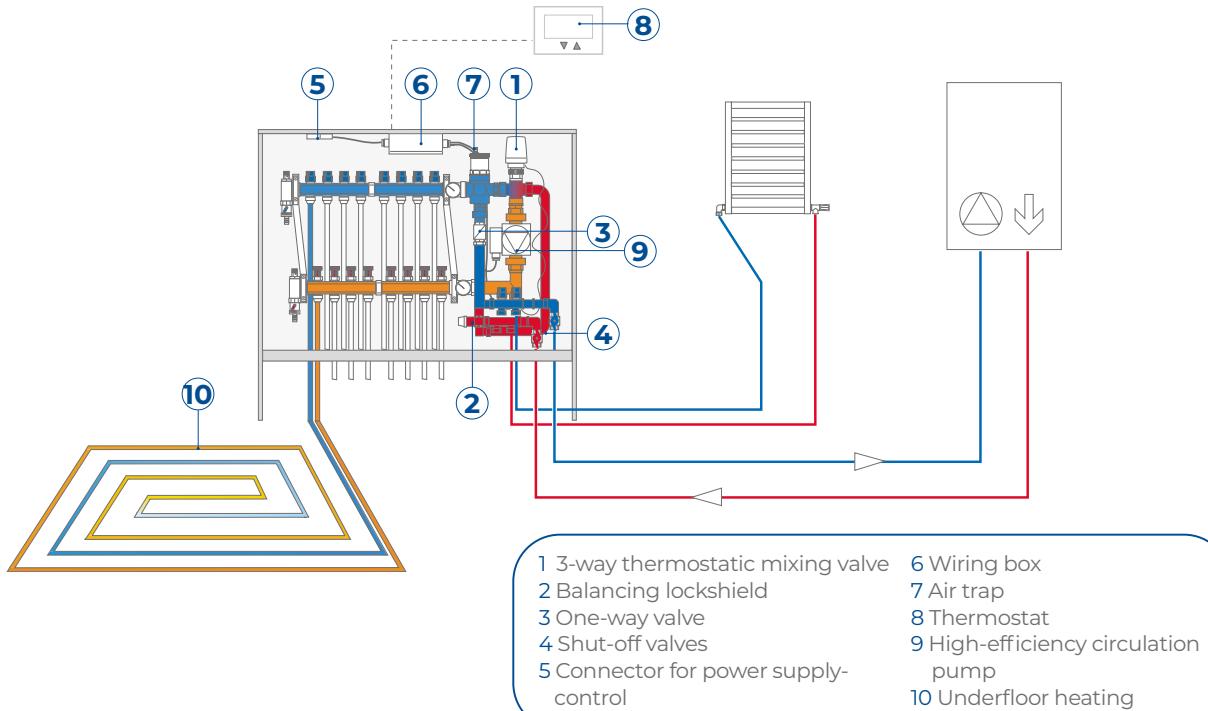

HYDRAULIC PERFORMANCES

(performance of electronic self-regulating circulator)

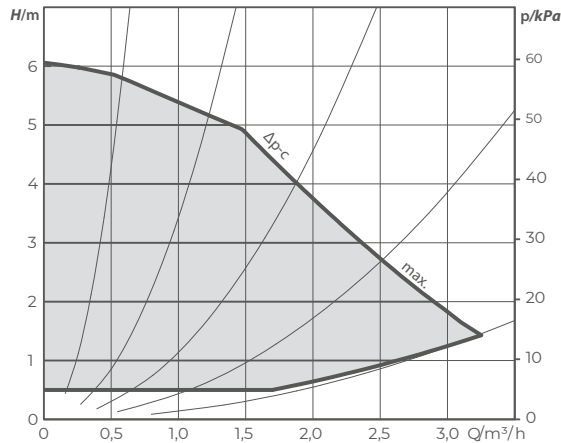

ACCESSORIES FOR PF KIT



Control Box for Kit PF

Pro control box for Kit PF including safety board and max temperature setting at 50 or 55 °C. The pump stops if the inflow temperature is higher than the set value. The alarm is shown by led. Automatic restarting when the temperature is lower than the set value. Input for heat generator (boiler or heat pump) and antiscuff device for the pump when the system is not used for a while.

MODEL	CODE
QE Pro	--

VJ 0-10 THERMOREGULATION KIT

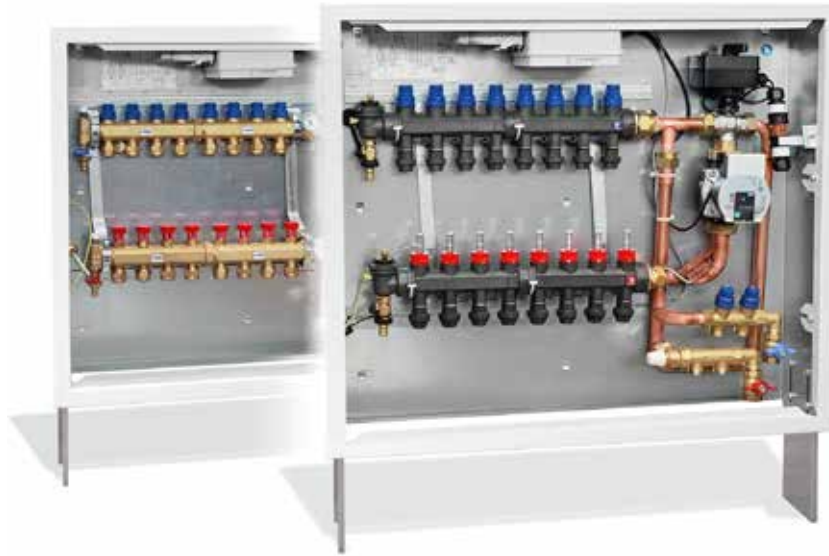

The kit is a device that includes in a single product suitable for installation in the room, the radiant distribution part (underfloor system), temperature control and high-temperature units for connecting up to 3 radiators. The **VJ** model, in particular, is suitable for managing system operation in both heating and cooling mode.

It is complete with metal cabinet with adjustable feet, brackets, protective cover for plaster, white door with lock and adjustable frame. Equipped with 3-way mixing valve, 0-10 analogue servomotor (electronic temperature control unit not included), electronic circulator, micrometric lockshield, one-way valve, shut-off valves, thermometers, air separator, anti-condensation insulation, balancing lockshield, air vent and system load/unload valves, electronic safety thermostat, pump with anti-seize function, connector for external electrical connection and is fully wired internally. Optionally, the kit can be equipped with high temperature connections (2 or 3 outlets).

The kit is available with CONTROL brass or TOP COMPOSIT technopolymer manifolds.

FEATURES

- Suitable for connection to generator with built-in pump
- Control with 3-way mixing valve
- Modulating servomotor 0-10V
- High efficiency electronic circulator
- Electrical wiring with IP 43 protection
- Ready for Wi or Trio Plus control unit
- Electronic safety thermostat
- Air separator and anti-condensation insulation
- Controllable high temperature outlets for radiators (optional)



- A Fill/drain taps
- B Return manifold
- C Power supply/command plugs
- D Control unit
- E Return thermometer
- F Servomotor
- G Mixing valve
- H Mixing valve control plug
- I Pump
- L Adjustment feet
- M Regulation holder
- N Balancing lockshield
- O Supply manifold
- P Cabinet
- Q Adapter for Ø 17 mm pipe
- R Terminal unit
- S 2 outlets HT manifold
- T 3 outlets HT manifold
- U 3-way air trap
- V Anti-condensation insulation kit

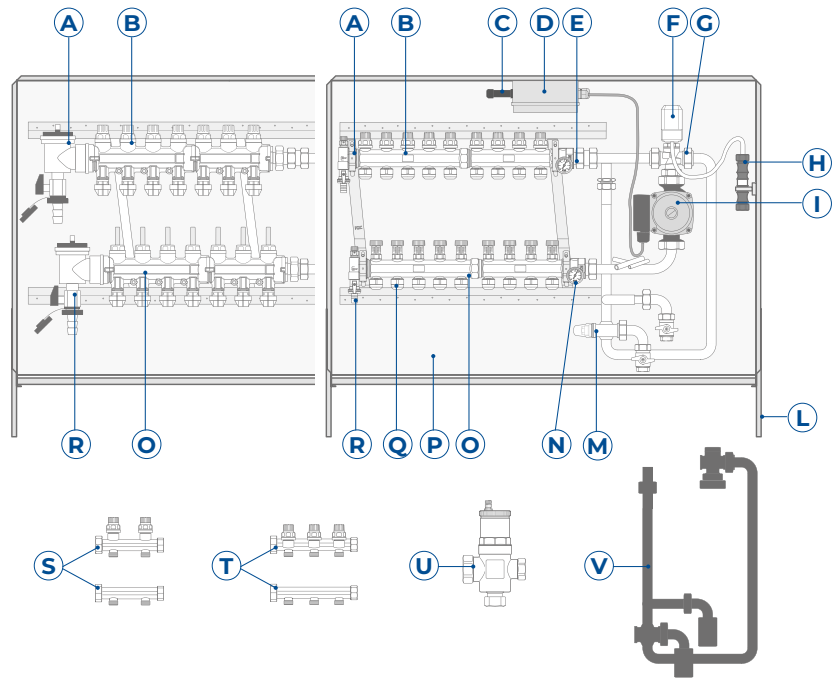

VJ 0-10 Kit with Top Composit manifold

n. outlets	dimensions l x h x p (cm)	code Ø 17
3+3	65x83÷89x14.5	3VP03N0QN7
4+4	65x83÷89x14.5	3VP04N0QN7
5+5	65x83÷89x14.5	3VP05N0QN7
6+6	80x83÷89x14.5	3VP06N0QN7
7+7	80x83÷89x14.5	3VP07N0QN7
8+8	80x83÷89x14.5	3VP08N0QN7
9+9	100x83÷89x14.5	3VP09N0QN7
10+10	100x83÷89x14.5	3VP10N0QN7
11+11	100x83÷89x14.5	3VP11N0QN7
12+12	100x83÷89x14.5	3VP12N0QN7

VJ 0-10 Kit with Control manifold

n. outlets	dimensions l x h x p (cm)	code Ø 17
3+3	65x83÷89x14.5	3VO03N0QN7
4+4	65x83÷89x14.5	3VO04N0QN7
5+5	65x83÷89x14.5	3VO05N0QN7
6+6	80x83÷89x14.5	3VO06N0QN7
7+7	80x83÷89x14.5	3VO07N0QN7
8+8	80x83÷89x14.5	3VO08N0QN7
9+9	100x83÷89x14.5	3VO09N0QN7
10+10	100x83÷89x14.5	3VO10N0QN7
11+11	100x83÷89x14.5	3VO11N0QN7
12+12	100x83÷89x14.5	3VO12N0QN7

FOR COMPLETE CODING REFER TO PAGE 221

Example
Thermoregulation with VJ 0-10 kit

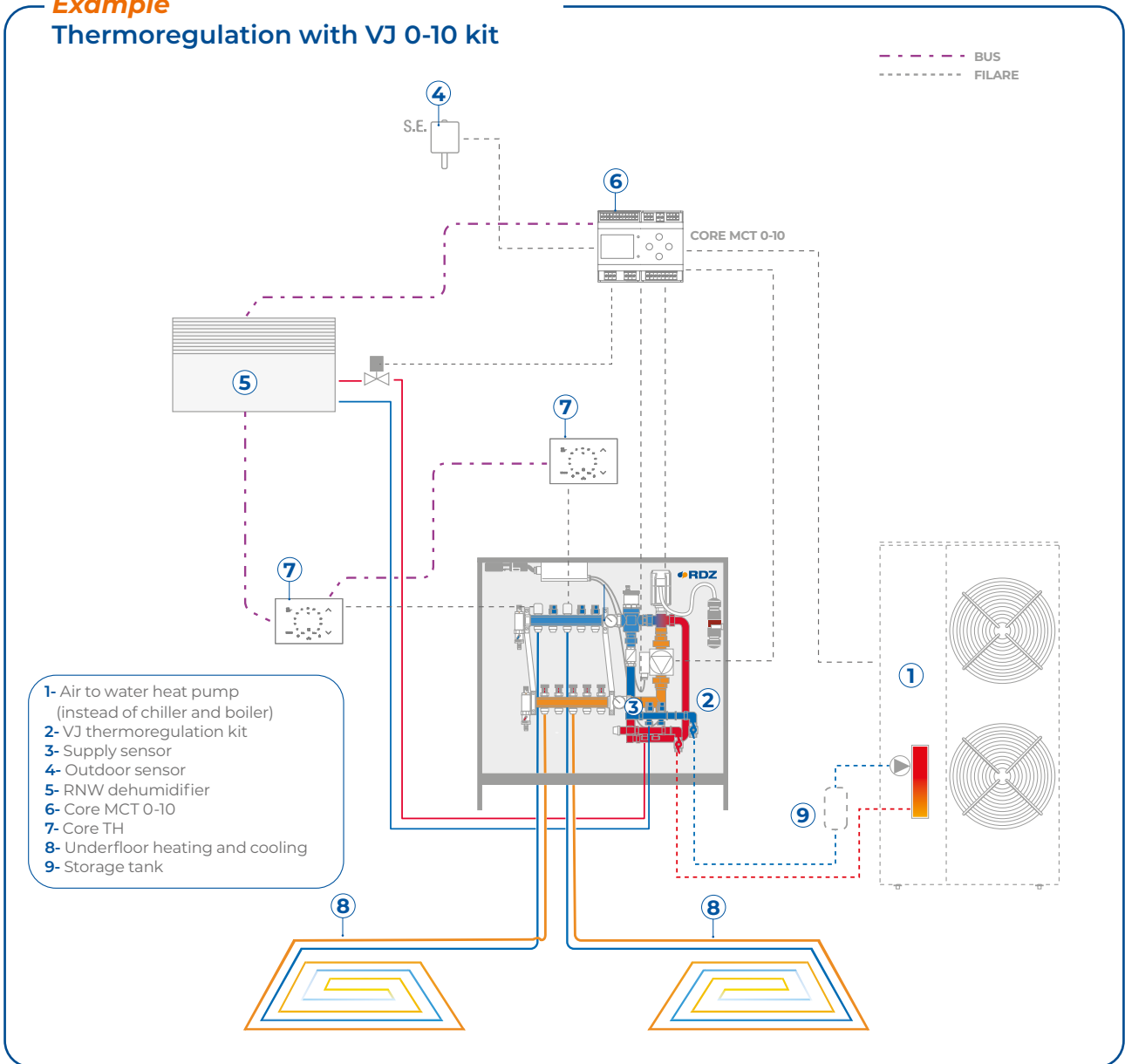

The proposed layout is indicative

HYDRAULIC PERFORMANCES

(performance of electronic self-regulating circulator)

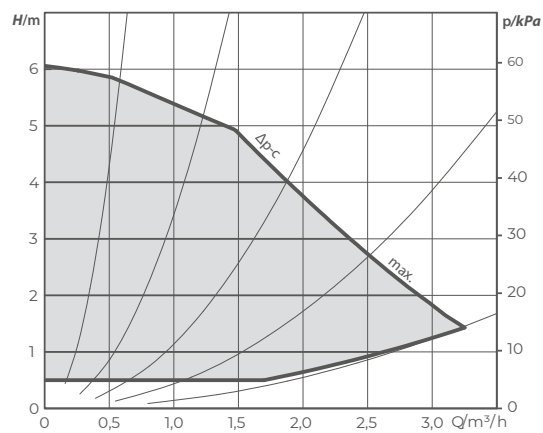

ACCESSORIES FOR KIT PF AND VJ



HT Manifolds with 2 or 3 outlets

Pair of manifolds made of brass diam. 3/4" MF, distance between outlets 45 mm, Eurocone 3/4" for the connection of Pex, multilayer or copper pipes. Electrothermic heads can be applied on the manifolds. They are available with 2 or 3 outlets.

SIZE	CODE
2 outlets	--
3 outlets	--



Fittings for PE-X e PB pipes

Squeeze fitting for use with blklimax, CONTROL and TOP COMPOSIT manifolds (on Eurocone adapter). (RDZ manifolds are already fitted with fittings).

SIZE	CODE
Ø 12	1118212
Ø 16	also for multilayer 1118118



Fittings for Multilayer Ø 20

Fittings for multilayer. They can be used with blklimax, CONTROL and TOP COMPOSIT manifolds.

SIZE	CODE
Ø 20x2	1186120



Closing Plug for manifolds

Blind cap used to close circuits on manifolds.

MODEL	CODE
For Top Composit	1185010
For Control and high-temperature	1057000



Eurocone Adapter Ø 3/4"

Pair of clutch Eurocone adapter Ø 3/4" to connect the pipes with TOP COMPOSIT manifold.

PACKAGE	SIZE	CODE
pair	Ø 3/4"	1186005

CODING SYSTEM

With the following coding system it is possible to configure the desired thermoregulation kit through a few simple steps.

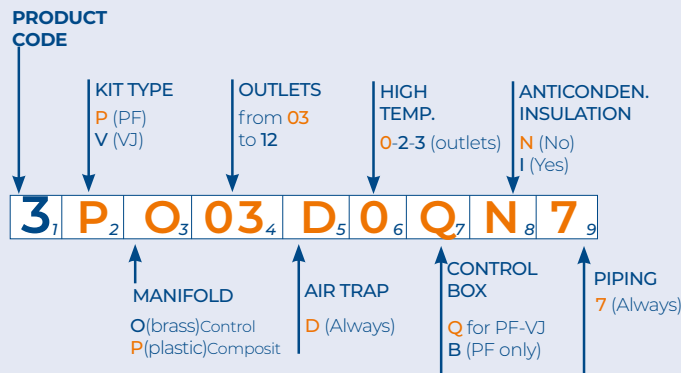

From left to right:

1) product code 2) type of kit: PF or VJ 3) type of manifold (brass or plastic) 4) number of manifold outlets 5) air trap 6) number of high temperature outlets 7) control box type 8) anti-condensation insulation included or not 9) pipe diameter 17 mm.



230 V Electrothermal Head

Electrothermic servocontrol to manage each circuit through room thermostat. It is provided with limit microswitch, and it can be installed in any position, even upsidedown. Display of the functioning mode (open/close), easy installation thanks to fast hooking adapter (supplied as standard). Input 230 V with and without limit microswitch. Degree of protection IP 54. It can be used with CONTROL e TOP-COMPOSIT manifolds.

VOLTAGE	CODE
230 V	1057230
230 V c/micro	1057240
24 V c/micro	1057250



2-Way Zone Valve

Zone valves are used to shut off the heat-transfer medium in air conditioning systems. When coupled with a thermo-electric actuator and controlled by a room thermostat, they automatically shut off the part of the plumbing circuit in which they inserted. They feature a high flow coefficient, which is why they are typically installed for zone control. Thanks to their special balanced obturator, they can work at high differential pressures. The valve is equipped with unions.

DN	OUTLETS	KV	CODE
20	Ø 3/4"	4.7	3002021
20	Ø 1"	4.7	3002026



Thermostatic Element

Thermostatic control head, progressive opening, length of capillary 2 m, knob with graduated scale, operating temperature up to 50 °C (heating only). Probe pocket included.

SIZE	CODE
50 °C	3200010



Valve Body - PF

3-way mixing valve activated by the thermostatic element. It is equipped with 3 unions.

VALVE BODY	OUTLETS	KV	CODE
15	Ø 1/2"	2.8	3222015
20	Ø 3/4"	3.2	3222020
25	Ø 1"	5.0	3222025



Servomotor N 300 and 0-10

The reversible electric motor can be manually activated, and it is equipped with limit microswitch. It can be installed on VM3 mixing valves (code 3270325-3270332-3270340). Stroke 6.5 mm. Protection class IP42.

TYPE	VOLTAGE	CODE
230	230 V	3270030
0-10	24 V	3270035

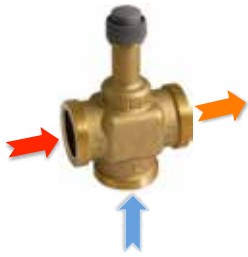

Valve Body VM3 1", 1" ¼ and 1" ½

The reversible electric motor can be manually activated, and it is equipped with limit microswitch. It can be installed on VM3 mixing valves (code 3270030 and 3270035). Stroke 6.5 mm. Protection class IP42.

VALVE BODY	DN VALVE	OUTLETS	KV	CODE
25	Ø 1"	Ø 1" ½	10	3270325
32	Ø 1" ¼	Ø 2"	16	3270332
40	Ø 1" ½	Ø 2" ¼	25	3270340



Pipe Unions for VM3 - 1", 1" ¼ and 1" ½

Three brass unions with flat gasket for mixing valves VM3.

VALVE BODY	DN VALVE	OUTLETS	PACK.	CODE
25	Ø 1"	Ø 1" ½ - Ø 1"	3 items	3235135
32	Ø 1" ¼	Ø 2" - Ø 1" ¼	3 items	3235142
40	Ø 1" ½	Ø 2" ¼ - Ø 1" ½	3 items	3235150



Servomotor - VJ

The reversible synchronous electric motor can be manually activated, and it is suitable for VM3 mixing valves (code 3270315-3270320-3270323) and for VJ valves (all versions).

TYPE	VOLTAGE	CODE
230	230 V	3230000
0-10	24 V	3230005

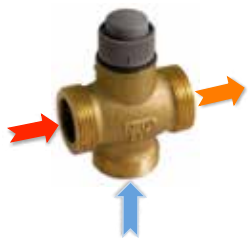

Valve Body VM3 ½", ¾" e 1"

Linear 3-way mixing valve, equipercantage regulation, stroke 6.5 mm, PN 16. It can be combined with reversible electric motor VJ of 230 V or 0-10.

VALVE BODY	DN VALVE	OUTLETS	KV	CODE
15	Ø ½"	Ø ½"	2.5	3270315
20	Ø ¾"	Ø ¾"	4.0	3270320
25	Ø 1"	Ø 1" ¼	6.3	3270323



Pipe Unions for VM3 ½", ¾" and 1"

Three brass unions with flat gasket for mixing valves VM3. Package: 3 items.

VALVE BODY	DN VALVE	OUTLETS	PACK.	CODE
15	Ø ½"	Ø ½" - Ø ⅜"	3 items	3235128
20	Ø ¾"	Ø ¾" - Ø ½"	3 items	3235130
25	Ø 1"	Ø 1" ¼ - Ø 1"	3 items	3235133



**Underfloor radiant
systems
for industrial
applications**





The ideal climate even in large spaces

Underfloor heating systems are particularly suitable for installation in buildings such as industrial ones with high heights, as the diffusion of heat by radiation allows heating at eye level.

The uniformity of the temperatures, in addition to ensuring a pleasant sensation of physical well-being, allows the system to be maintained at a very low operating temperature, significantly reducing consumption compared to traditional systems. The low temperature of the thermovector fluid also allows the use of energy generators from renewable sources.

The absence of convective motions eliminates the movement of dust and impurities in the air, safeguarding the proper functioning of machinery and preserving the healthiness of the rooms; the integration in the floor facilitates cleaning and makes all the surfaces fully exploitable for work activities as they are clutter-free.

Lastly, the industrial radiant underfloor heating system has no contraindications in terms of fire prevention as it does not include flammable components or high-temperature parts.

INDUSTRIAL UNDERFLOOR RADIANT SYSTEMS ADVANTAGES:



***USE OF RENEWABLE
ENERGY SOURCES***



***THERMAL COMFORT
WITHOUT WASTE***



***ABSENCE OF MOVEMENT
OF AIR AND DUST***



***OPTIMISATION
OF SPACES***



***NO MAINTENANCE
COSTS***



Industrial shaped panel system is a low-temperature underfloor heating system characterised by pipes anchored to an insulated base and embedded in the screed.

It is an ideal solution to benefit from the installation advantages offered by a civil system even in the case of large industrial buildings.

The central element of the system is the industrial shaped panel with studs made of expanded polystyrene in compliance with UNI EN 13163, with dimensions 1170x837x20 mm, characterised by high mechanical resistance.

Equipped with joints on all four sides to facilitate panel coupling, it can be laid directly on rolled screed and stabilised after appropriate waterproofing.

The system is completed with high-density cross-linked PE-Xc Ø 20 mm RDZ Tech pipe, with anti-oxygen barrier according to DIN 4726, hook clips, support open elbows, manifold, industrial perimeter belt, sleeves to protect the expansion joints and light felt to be used as thermal insulation.

FEATURES

- Panel with high compressive strength
- RDZ Tech PE-Xc pipe Ø 20 mm
- Specific system for industrial buildings
- Good thermal insulation
- Fast installation



SECTION AND DIMENSIONS

- 1 Quartz
- 2 Concrete
- 3 RDZ Tech pipe Ø 20-16
- 4 Insulation edge
- 5 Reinforced mesh
- 6 Industrial Shaped Panel
- 7 Nylon
- 8 Hooked clip
- 9 Fixed rolled screed

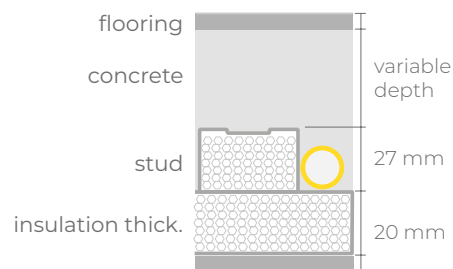
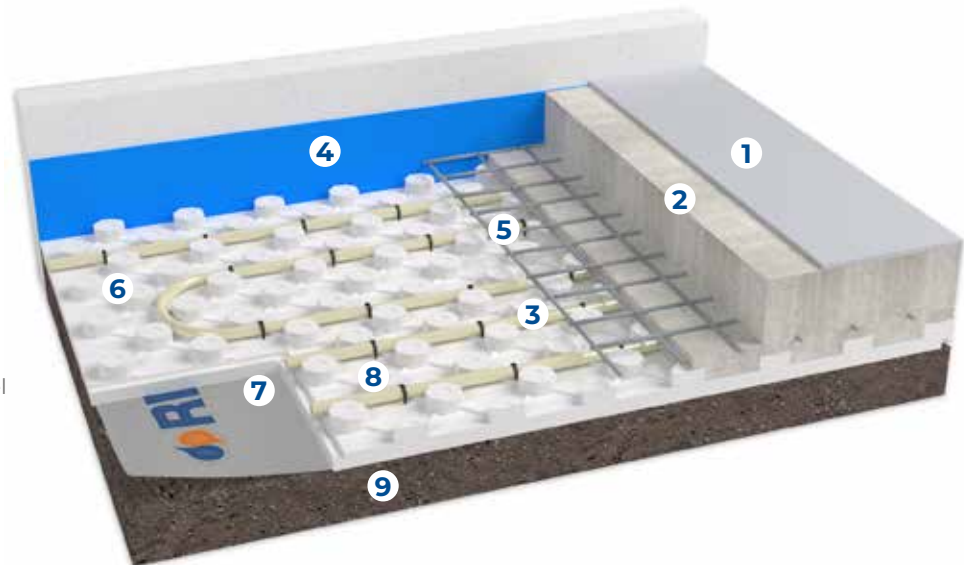

PRODUCTS THAT COMPOSE THE SYSTEM

Industrial shaped panel



It is a waterproof panel, made of moulded expanded polystyrene (according to UNI 13163), which has high mechanical resistance. These panels are provided with a tongue along the perimeter to connect them for proper alignment. They have a moulded surface with reliefs of 27 mm, so that the cross-linked polyethylene pipes (Ø 20 mm) can be fitted into the tabs of the panel at intervals of 8.3 cm or multiples.

SIZE	THICKNESS	CODE
1170x837 mm	20 mm	1040232

Panel features	Value	Unit	Standard
Size	1170x837x20	mm	UNI 822
Standard thickness	47	mm	UNI 823
Insulation base thickness	20	mm	
Thermal conductivity 10 °C	0.033	W/(m · K)	UNI EN 12667
Compressive stress at 10% deformation	200	kPa	UNI 826
Resistance to compression with 5% deformation	180	kPa	UNI 826
Resistance to compression with 2% deformation	130	kPa	UNI 826
Thermal resistance	0.60	(m ² · K)/W	UNI EN 13163
Equivalent total thickness	26.5	mm	UNI EN 1264-3
Water vapour diffusion resistance factor	40 to 100	1	UNI EN 12086
Limit of operating temperature	70	°C	
Fire reaction	F	Euroclass	EN ISO 11925-2
Declaration according to UNI EN 13163	EPS-EN13163-T1-L1-W1-S2-P4-BS250-CS(10)200-DS(70,-)1-WL(T)3-MU(40-100)		



RDZ Tech PE-Xc Pipe Ø 20 Interior Layer

RDZ Tech pipe Ø 20-16 mm made of high-density electrophysically cross-linked polyethylene with oxygen barrier. This pipe is produced according to DIN EN ISO 15875/2 and DIN 4726.

TYPE	ROLL	CODE
PE-Xc	240 m	1012240
PE-Xc	600 m	1012600



RDZ PE-RT pipe Ø 20-16

RDZ EASY 5-layer PE-RT (non-crosslinked Polyethylene of Raised Temperature) provided with EVOH anti-oxygen according to DIN 4726, it is suitable for underfloor heating and cooling systems.

TYPE	ROLL	CODE
PE-RT	600 m	1014766



Industrial Perimeter Belt

Industrial edge insulation to absorb floor expansions and eliminate heat or acoustic channels in the walls. It is made of expanded polyethylene with 100% closed cell structure, and it has an adhesive strip on one side.

SIZE	CODE
10x300 mm	1071110



Humidity Barrier Sheet

The polyethylene sheet should be laid under the insulating panel, thus acting as a humidity barrier.

SIZE	PACKAGE	CODE
Th. 0.18 mm	custom-made	1901100



Open elbow

Open elbow Ø 20 made of plastic material. It is used to support the pipes near the manifolds vertically and to protect them from any damage.

SIZE

Ø 20 mm

CODE

1140020



Hooked clip

Hooked clips made of plastic material to ensure secure positioning of the pipe on the insulating panels.

PACKAGE

100 pieces

CODE

1017000

Tips for material calculation

Needed products	Requirements
Industrial Shaped Panel	Area to be covered +2%
Humidity Barrier Sheet	Area to be covered +20%
RDZ Tech PE-Xc pipe 20x2	Depending on the average pitch Total length = area/pitch [m/m]
Industrial Perimeter Belt h 300 mm	Calculate the perimeter of the building
Hooked clip	5 for each circuit
Open elbow Ø 20	2 for each circuit
Optional products	Requirements
Sleeve for expansion joints Ø28 mm	2 for each crossing of a joint

Manifolds, heads, accessories and optional products (from page 240).

Note: The requirements in the table are indicative. Please refer to the construction project for confirmation.

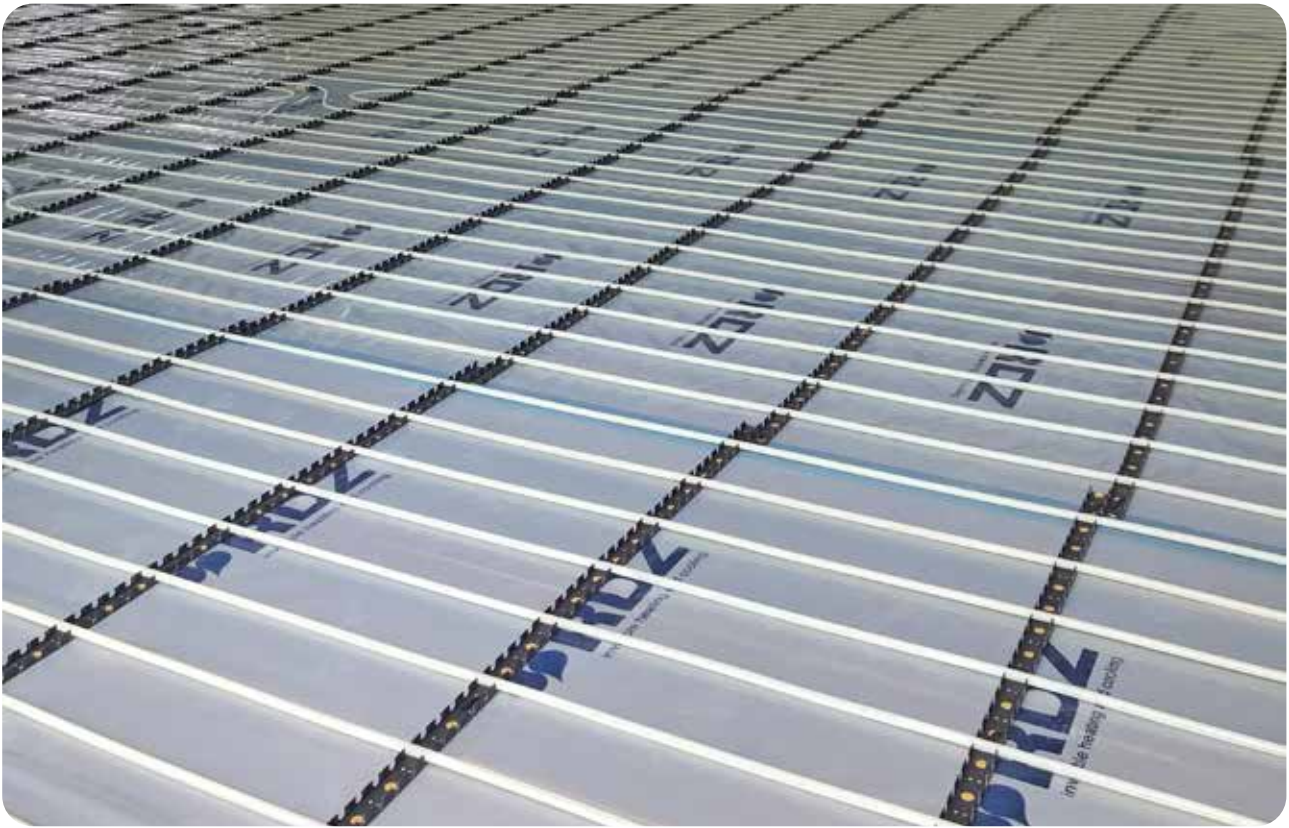

PVC bar system is a solution for underfloor heating in industrial buildings characterised by pipes housed in a support bar anchored to an insulating panel base.

The central element of the system is the PVC bar with U-shaped profile in which the PE-Xc Ø 20 or PE-Xa 25 mm pipe is placed. Thanks to the lower adhesive backside and special plastic fixing clips, the bar is anchored to the insulation layer made of smooth panel made of extruded expanded polystyrene produced with ecological CFC, HCFC and HFC-free gases, characterised by high compressive strength and available in different thicknesses (from 20 to 80 mm).

The system is completed with the humidity barrier sheet to protect the insulation, the open support elbows, the manifold, the industrial perimeter frame, the joint sleeve to protect the expansion joints and the light felt to be used as a thermal insulation.

FEATURES

- RDZ Tech PE-Xc pipe Ø 20 mm or PE-Xa pipe Ø 25 mm
- Specific system for industrial buildings
- Thermal insulation with high compressive strength panel
- Wide range of insulation thicknesses (20-30-40-50-60 or 80 mm)
- Easy installation



SECTION AND DIMENSIONS

- 1 Quartz
- 2 Concrete
- 3 RDZ Tech pipe Ø 20 or 25
- 4 Industrial perimeter belt
- 5 Reinforced mesh
- 6 Supporting bar
- 7 Smooth extruded panel
- 8 Fixing Clip
- 9 Fixed rolled screed

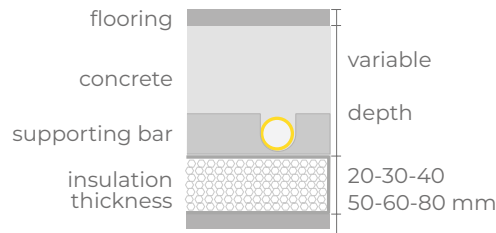
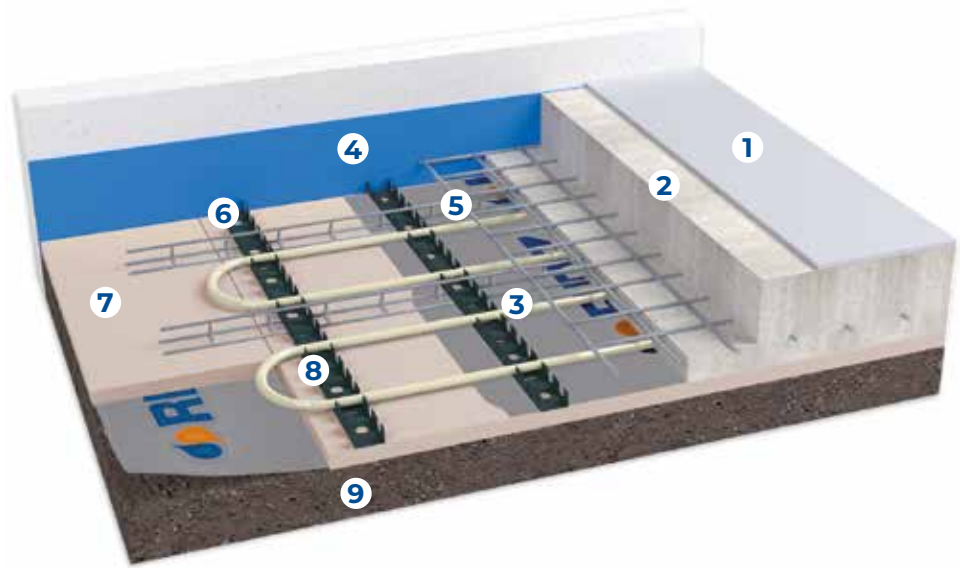

PRODUCTS THAT COMPOSE THE SYSTEM

Smooth extruded panel



Insulating panels made of extruded expanded polystyrene, produced with ecological gas, without CFC and HCFC, conforming to the European regulations EC 2037/2000. They have a closed-cell structure and react to fire according to Euroclass E. Compressive strength with 10% of deformation according to EN 826 between 250 and 400 kPa depending on the panel height.

SIZE	THICKNESS	CODE
1250x600 mm	20 mm	1030231
1250x600 mm	30 mm	1130130
1250x600 mm	40 mm	1130140
1250x600 mm	50 mm	1130150
1250x600 mm	60 mm	1130160
1250x600 mm	80 mm	1130180

Panel features - Smooth extruded panel	Symbol	20	30	40	50	60	80	Unit	Standard
Necessary Length	L1	1250						mm	EN 822
Necessary Width	W1	600						mm	EN 822
Total Thickness	T4	20	30	40	50	60	80	mm	EN 823
Compressive stress at 10% deformation	CS(10\Y)	250	300					kPa	EN 826
Creep - Compressive load with continuous stress 2%	CC(2/1,5/50)	NPD	130					kPa	EN 1606
Thermal conductivity at 10 °C	λ_D	0.033					0.035	W/(m·K)	EN 12667
Thermal resistance	R_D	0.60	0.90	1.20	1.50	1.80	2.25	(m ² ·K)/W	EN 13163
Long term water absorption by diffusion	WD(V)	3				2		Vol. %	EN 12088
Long-term water absorption by total immersion	WL(T)	0.7						Vol. %	EN 12087
Dimension stability (70°C, 90% r.h.)		DS(70, 90)						Class	EN 1604
Water vapour resistance factor	μ (MU)	150							EN 12086
Deformation under specific load and temperature conditions		NPD	DLT(2)5					Class	EN 1605
Reaction to fire		E						Euroclass	EN 13501-1
Tensile strength perpendicular to the faces		NPD	TR200					Kpa	EN 1607
Freeze-thaw resistance		NPD	FTCD1					Vol %	EN 12091
Max operating temperature		70						°C	
Weight		450	720	940	1160	1380	1940	g	
Specific heat	C	1450						J/kg·K	EN 10456
Declaration according to UNI EN 13164									
Unique product-type identification code: XPS -EN 13164:2012+A1:2015-T1-CS(10\Y)250-MU150 (thickness 20 mm) XPS -EN 13164-T1-CS(10\Y)300-DLT(2)5-DS(70,90)-WL(T)0,7-WD(V)5-FTCD1-MU150 (thickness 30 / 40 mm) XPS -EN 13164-T1-CS(10\Y)300-DLT(2)5-DS(70,90)-WL(T)0,7-WD(V)3-FTCD1-MU150- CC(2/1,5/50)120 (thickness 50 / 80 mm)									

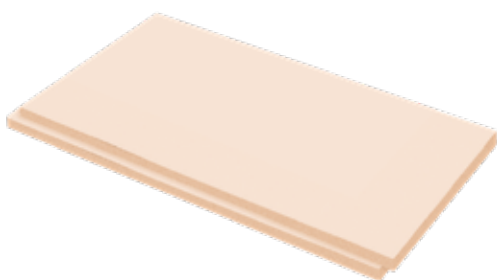

Smooth extruded panel 500 kPa

Extruded polystyrene foam insulation board produced using environmentally friendly, CFC- and HCFC-free gases, in accordance with European regulation EC 2037/2000, with thermoplastic properties and a closed-cell structure, which gives the product excellent thermal and mechanical properties. The panel has excellent insulating properties and thanks to its low thermal conductivity and therefore high thermal resistance, it provides optimal thermal insulation, allowing for high energy savings.

SIZE	THICKNESS	CODE
1250x600 mm	50 mm	1150150
1250x600 mm	60 mm	1150160
1250x600 mm	80 mm	1150180

Panel features - 500 kPa	Symbol	50	60	80	Unit	Standard
Necessary Length	L1	1250 ± 8			mm	EN 822
Necessary Width	W1	600 ± 3			mm	EN 822
Total Thickness	T4	50 ± 3	60 ± 3	80 ± 3	mm	EN 823
Compressive stress at 10% deformation	CS(10\Y)	500			kPa	EN 826
Creep - Compressive load with continuous stress 2%	CC(2/1,5/50)	180			kPa	EN 1606
Thermal conductivity at 10 °C	λ_D	0.033		0.035	W/(m·K)	EN 12667
Thermal resistance	R_D	1.50	1.80	2.25	(m ² ·K)/W	EN 13163
Long term water absorption by diffusion	WD(V)	3	2		Vol. %	EN 12088
Long-term water absorption by total immersion	WL(T)	0.7			Vol. %	EN 12087
Dimension stability (70°C, 90% r.h.)		DS(70,90)			Class	EN 1604
Water vapour resistance factor	μ (MU)	150				EN 12086
Deformation under specific load and temperature conditions		DLT(2)5			Class	EN 1605
Reaction to fire		E			Euroclass	EN 13501-1
Tensile strength perpendicular to the faces		TR200			Kpa	EN 1607
Freeze-thaw resistance		FTCD1			Vol %	EN 12091
Max operating temperature		70			°C	
Weight		1350	1590	1800	g	
Specific heat	C	1450			J/kg·K	EN 10456
Declaration according to UNI EN 13164						
Class: 500						
Unique identification code: XPS-UNI EN 13164:2015-T1-CS(10\Y)500-DLT(2)5-DS(70,90)-WL(T)0,7-WD(V)2,3-FTCD1-MU150						



Supporting Bars for Pipes Ø 20 and Ø 25

Supporting bar made of PVC for RDZ Industrial System, which is used to fix piping Ø 20 or 25 mm. The bar has an adhesive strip on the backside, so that it can be fixed on the polyethylene foil with or without the insulating panel. Size for supporting bar Ø 20 mm: 4000x25x50 mm. Pipe spacing: 50 mm. Size for supporting bar Ø 25 mm: 4000x35x50 mm. Pipe spacing: 100 mm.

SIZE	CODE
Ø 20 mm - 4000x25x50 mm	1062120
Ø 25 mm - 4000x35x50 mm	1062125



RDZ Tech PE-Xc Pipe Ø 20 Interior Layer

RDZ Tech pipe Ø 20-16 mm made of high-density electrophysically cross-linked polyethylene with oxygen barrier. This pipe is produced according to DIN EN ISO 15875/2 and DIN 4726.

TYPE	ROLL	CODE
PE-Xc	240 m	1012240
PE-Xc	600 m	1012600



RDZ PE-RT pipe Ø 20-16

RDZ EASY 5-layer PE-RT (non-crosslinked Polyethylene of Raised Temperature) provided with EVOH anti-oxygen according to DIN 4726, it is suitable for underfloor heating and cooling systems.

TYPE	ROLL	CODE
PE-RT	600 m	1014766



RDZ Tech PE-Xa Pipe Ø 25 Interior Layer

RDZ Tech PE-Xa pipe Ø 25-20.4 made of high-density polyethylene with type-a cross-linking. This pipe is produced according to DIN 16892 and DIN 4726.

TYPE	ROLL	CODE
PE-Xa	200 m	1013920
PE-Xa	600 m	1013900



Industrial Perimeter Belt

Industrial edge insulation to absorb floor expansions and eliminate heat or acoustic channels in the walls. It is made of expanded polyethylene with 100% closed cell structure, and it has an adhesive strip on one side.

SIZE	CODE
10x300 mm	1071110



Fixing clip

The fixing clips are made of plastic material and they are used to secure the reinforcement mesh.

PACKAGE	CODE
500 pieces	1111000



Humidity Barrier Sheet

The polyethylene sheet should be laid under the insulating panel, thus acting as a humidity barrier.

SIZE	PACKAGE	CODE
Th. 0.18 mm	custom-made	1901100



Open elbow

Open elbow made of plastic material. It is used to support the pipes near the manifolds vertically and to protect them from any damage.

SIZE	CODE
Ø 20 mm	1140020
Ø 25 mm	1140025

Tips for material calculation

Needed products	Requirements
Smooth extruded panel	Area to be covered +2%
Humidity Barrier Sheet	Area to be covered +20%
RDZ Tech pipe PE-Xc Ø 20x2 or PE-Xa Ø 25x2	As a function of average pitch Total length = area/pitch [m/m]
Industrial perimeter belt h300 mm	Calculate the perimeter of the building
PVC support bar	0.9 m every m ²
Clips for fixing PVC bar to insulation	1 clip for each metre of bar
Open elbow Ø 20 or Ø 25	2 for each circuit
Optional products	Requirements
Sleeving for expansion joints	2 for each crossing of a joint
Hose clamps	6 clamps for each circuit

Manifolds, heads, accessories and optional products (from page 240).

Note: The requirements in the table are indicative. Please refer to the construction project for confirmation.



Industrial mesh system is a solution for underfloor heating in industrial buildings characterised by piping anchored to the mesh by special clips and embedded in the screed.

The system is ideal for winter air-conditioning of large warehouses and can be laid directly on rolled and stabilised gravel after suitable waterproofing.

The central element of the system is the RDZ Tech PE-Xc pipe \varnothing 20 mm anchored to the electro-welded net \varnothing 6 (not supplied by RDZ) by special industrial clips made of plastic material. For heating large surfaces, PE-Xa pipe \varnothing 25 can be used combined with 2" diameter stainless steel manifolds.

The system can be optionally combined with the smooth extruded panel made of extruded polystyrene foam, characterised by high compressive strength and available in different insulation thicknesses (from 20 to 80 mm).

The solution is completed with the moisture barrier sheet to protect the insulation, the support curves, the manifold, the industrial perimeter frame, the sheathing to protect the expansion joints and the needle felt to be used as a thermal break.

FEATURES

- Panel with high compressive strength
- RDZ Tech pipe in PE-Xc \varnothing 20 or PE-Xa \varnothing 25
- Specific system for industrial buildings
- Possibility of thermal insulation with 20, 30, 40, 50, 60 or 80 mm extruded smooth panel
- Easy installation



SECTION AND DIMENSIONS

- 1 Quartz
- 2 Concrete
- 3 RDZ Tech pipe Ø 20 or Ø 25
- 4 Industrial perimeter belt
- 5 Reinforced mesh
- 6 Smooth extruded panel
- 7 Nylon
- 8 Clip Industry
- 9 Anti-shrinkage mesh Ø 6
- 10 Fixed rolled screed

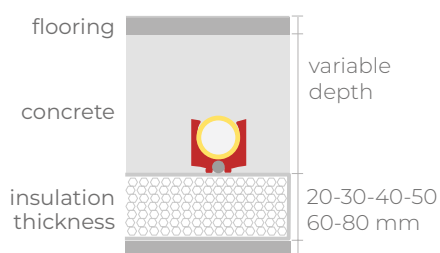
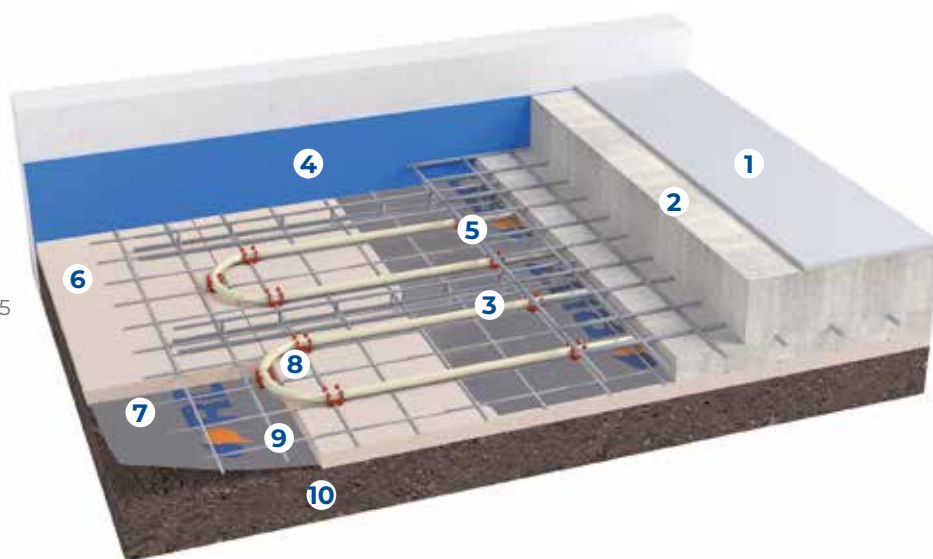

PRODUCTS THAT COMPOSE THE SYSTEM



Smooth extruded panel

Insulating panels made of extruded expanded polystyrene, produced with ecological gas, without CFC and HCFC, conforming to the European regulations EC 2037/2000. They have a closed-cell structure and react to fire according to Euroclass E. Compressive strength with 10% of deformation according to EN 826 between 250 and 400 kPa depending on the panel height.

SIZE	THICKNESS	CODE
1250x600 mm	20 mm	1030231
1250x600 mm	30 mm	1130130
1250x600 mm	40 mm	1130140
1250x600 mm	50 mm	1130150
1250x600 mm	60 mm	1130160
1250x600 mm	80 mm	1130180

Panel features - Smooth extruded panel	Symbol	20	30	40	50	60	80	Unit	Standard
Necessary Length	L1	1250						mm	EN 822
Necessary Width	W1	600						mm	EN 822
Total Thickness	T4	20	30	40	50	60	80	mm	EN 823
Compressive stress at 10% deformation	CS(10\Y)	250	300					kPa	EN 826
Creep - Compressive load with continuous stress 2%	CC(2/1,5/50)	NPD	130					kPa	EN 1606
Thermal conductivity at 10 °C	λ_D	0.033					0.035	W/(m·K)	EN 12667
Thermal resistance	R_D	060	0.90	1.20	1.50	1.80	2.25	(m ² ·K)/W	EN 13163
Long term water absorption by diffusion	WD(V)	3				2		Vol. %	EN 12088
Long-term water absorption by total immersion	WL(T)	0.7						Vol. %	EN 12087
Dimension stability (70°C, 90% r.h.)		DS(70, 90)						Class	EN 1604
Water vapour resistance factor	μ (MU)	150							EN 12086
Deformation under specific load and temperature conditions		NPD	DLT(2)5					Class	EN 1605
Reaction to fire		E						Euroclass	EN 13501-1
Tensile strength perpendicular to the faces		NPD	TR200					Kpa	EN 1607
Freeze-thaw resistance		NPD	FTCD1					Vol %	EN 12091
Max operating temperature		70						°C	
Weight		450	720	940	1160	1380	1940	g	
Specific heat	C	1450						J/kg·K	EN 10456
Declaration according to UNI EN 13164									
Unique product-type identification code: XPS -EN 13164:2012+A1:2015-T1-CS(10/Y)250-MU150 (thickness 20 mm) XPS -EN 13164-T1-CS(10/Y)300-DLT(2)5-DS(70,90)-WL(T)0,7-WD(V)5-FTCD1-MU150 (thickness 30 / 40 mm) XPS -EN 13164-T1-CS(10/Y)300-DLT(2)5-DS(70,90)-WL(T)0,7-WD(V)3-FTCD1-MU150- CC(2/1,5/50)120 (thickness 50 / 80 mm)									

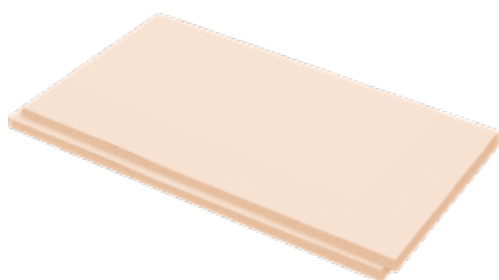

Smooth extruded panel 500 kPa

Extruded polystyrene foam insulation board produced using environmentally friendly, CFC- and HCFC-free gases, in accordance with European regulation EC 2037/2000, with thermoplastic properties and a closed-cell structure, which gives the product excellent thermal and mechanical properties. The panel has excellent insulating properties and thanks to its low thermal conductivity and therefore high thermal resistance, it provides optimal thermal insulation, allowing for high energy savings.

SIZE	THICKNESS	CODE
1250x600 mm	50 mm	1150150
1250x600 mm	60 mm	1150160
1250x600 mm	80 mm	1150180

Panel features - 500 kPa	Symbol	50	60	80	Unit	Standard
Necessary Length	L1	1250 ± 8			mm	EN 822
Necessary Width	W1	600 ± 3			mm	EN 822
Total Thickness	T4	50 ± 3	60 ± 3	80 ± 3	mm	EN 823
Compressive stress at 10% deformation	CS(10\Y)	500			kPa	EN 826
Creep - Compressive load with continuous stress 2%	CC(2/1,5/50)	180			kPa	EN 1606
Thermal conductivity at 10 °C	λ_D	0.033		0.035	W/(m·K)	EN 12667
Thermal resistance	R_D	1.50	1.80	2.25	(m ² ·K)/W	EN 13163
Long term water absorption by diffusion	WD(V)	3	2		Vol. %	EN 12088
Long-term water absorption by total immersion	WL(T)	0.7			Vol. %	EN 12087
Dimension stability (70°C, 90% r.h.)		DS(70,90)			Class	EN 1604
Water vapour resistance factor	μ (MU)	150				EN 12086
Deformation under specific load and temperature conditions		DLT(2)5			Class	EN 1605
Reaction to fire		E			Euroclass	EN 13501-1
Tensile strength perpendicular to the faces		TR200			Kpa	EN 1607
Freeze-thaw resistance		FTCD1			Vol %	EN 12091
Max operating temperature		70			°C	
Weight		1350	1590	1800	g	
Specific heat	C	1450			J/kg·K	EN 10456
Declaration according to UNI EN 13164						
Class: 500						
Unique identification code: XPS-UNI EN 13164:2015-T1-CS(10\Y)500-DLT(2)5-DS(70,90)-WL(T)0,7-WD(V)2,3-FTCD1-MU150						



RDZ Tech PE-Xc Pipe Ø 20 Interior Layer

RDZ Tech pipe Ø 20-16 mm made of high-density electrophysically cross-linked polyethylene with oxygen barrier. This pipe is produced according to DIN EN ISO 15875/2 and DIN 4726.

TYPE	ROLL	CODE
PE-Xc	240 m	1012240
PE-Xc	600 m	1012600



RDZ PE-RT pipe Ø 20-16

RDZ EASY 5-layer PE-RT (non-crosslinked Polyethylene of Raised Temperature) provided with EVOH anti-oxygen according to DIN 4726, it is suitable for underfloor heating and cooling systems.

TYPE	ROLL	CODE
PE-RT	600 m	1014766



RDZ Tech PE-Xa Pipe Ø 25 Interior Layer

RDZ Tech PE-Xa pipe Ø 25-20.4 made of high-density polyethylene with type-a cross-linking. This pipe is produced according to DIN 16892 and DIN 4726.

TYPE	ROLL	CODE
PE-Xa	200 m	1013920
PE-Xa	600 m	1013900



Industrial Perimeter Belt

Industrial edge insulation to absorb floor expansions and eliminate heat or acoustic channels in the walls. It is made of expanded polyethylene with 100% closed cell structure, and it has an adhesive strip on one side.

SIZE	CODE
10x300 mm	1071110



Red clips for 6-mm wire mesh and 20-mm pipe

Fixing clips for piping Ø 20 mm, made of plastic material. They are used to hold the pipe on the electro-welded mesh Ø 6 mm. The distance between rods represents the pipe spacing. Easy installation thanks to clip fixer.

SIZE	CODE
Ø 20x6 mm	1140640



Industrial Clips 25/6

Fixing clips for pipes Ø 25 mm made of plastic to support the pipe with the welded mesh Ø 6 mm. The single meshes should correspond to the spacing between the pipes.

SIZE	CODE
Ø 25x6 mm	1140625



Open elbow

Open elbow made of plastic material. It is used to support the pipes near the manifolds vertically and to protect them from any damage.

SIZE	CODE
Ø 20 mm	1140020
Ø 25 mm	1140025



Humidity Barrier Sheet

The polyethylene sheet should be laid under the insulating panel, thus acting as a humidity barrier.

SIZE	PACKAGE	CODE
Th. 0.18 mm	custom-made	1901100

Tips for material calculation

Needed products	Requirements
Smooth extruded panel	Area to be covered +2%
Humidity Barrier Sheet	Area to be covered +20%
RDZ Tech pipe PE-Xc Ø 20x2 or PE-Xa Ø 25x2	As a function of average pitch. Total length = area/pitch [m/m]
Industrial perimeter belt h 300 mm	Calculate the perimeter of the building
Clips for mesh Ø 6 mm, pipe Ø 20 o 25 mm	1.5 per metre of pipe
Open elbow Ø 20 or 25	2 for each circuit

Optional products	Requirements
Sleeving for expansion joints	2 for each crossing of a joint
Hose clamps	6 clamps for each circuit

Manifolds, heads, accessories and optional products (from page 240).

Note: The requirements in the table are indicative. Please refer to the construction project for confirmation.

***Underfloor radiant
systems
for industrial
applications***

Complements



Control Pre-assembled Manifold

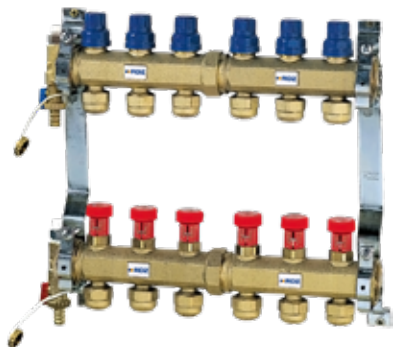

CONTROL manifolds $\varnothing 1\frac{1}{4}$ are made of brass, and they are used to distribute the pipes into the rooms. They are provided with on-off valves (suitable for electrothermic heads), micrometric lockshields with data labels to locate rooms, ball air vent valves and ball drain valves with hose nozzles and plugs, brackets with vibration-damping rubber tops, which can be installed in cabinets or on the wall, and fittings for pipes $\varnothing 14$ or $\varnothing 17$ mm.

Performance / size	Value	Unit
Liquid	water, glycolic water 30% at most	
Max. Operating Pressure	6	bar
Max. Testing Pressure	10	bar
Operating Temperature	5÷100	°C
Main outlets of the manifold	1" 1/4 F distance between axis 210	mm
Derivations	pipe clamp fitting 3/4" 14 - 17 - 20 distance between axis 50	\varnothing mm

outlets	code $\varnothing 20$
3+3	1153903
4+4	1153904
5+5	1153905
6+6	1153906
7+7	1153907
8+8	1153908
9+9	1153909
10+10	1153910
11+11	1153911
12+12	1153912
13+13	1153913

Dimension of the manifold												
Number of outlet		3+3	4+4	5+5	6+6	7+7	8+8	9+9	10+10	11+11	12+12	13+13
Only control manifold	cm	24,5	29,5	35,5	41	46	51	56	61	67,5	72,5	77,5
Control + Initial Fittings	cm	28	33	39	44,5	49,5	54,5	59,5	64,5	71	76	81
Control + Ball Valves	cm	34,5	39,5	45,5	51	56	61	66	71	77,5	82,5	87,5
Control + Zone Valve	cm	38	43	49	54,5	59,5	64,5	69,5	74,5	81	86	91
Control + Initial Fittings + Ball Valves	cm	38	43	49	54,5	59,5	64,5	69,5	74,5	81	86	91
Control + Initial Fittings + Zone Valve	cm	41,5	46,5	52,5	58	63	68	73	78	84,5	89,5	94,5
Control + Ball Valves + Zone Valve	cm	42,5	47,5	53,5	59	64	69	74	79	85,5	90,5	95,5
Control with all accessories	cm	47	52	58	63,5	68,5	73,5	78,5	83,5	90	95	>100

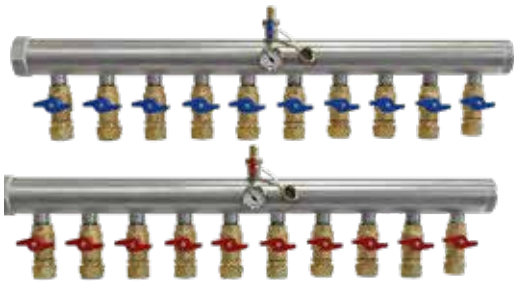

Industry Manifold

Industry manifold made of stainless steel Ø 2", used to distribute pipes Ø 25 mm in warehouses. It includes shut-off ball valves and registers, an air and load cock, inflow and return thermometers (0-60 °C), fittings for pipes Ø 25 mm.

outlets	code Ø 20	code Ø 25	outlets	code Ø 20	code Ø 25
5+5	1145205	1145005	11+11	1145211	1145011
6+6	1145206	1145006	12+12	1145212	1145012
7+7	1145207	1145007	13+13	1145213	1145013
8+8	1145208	1145008	14+14	1145214	1145014
9+9	1145209	1145009	15+15	1145215	1145015
10+10	1145210	1145010			



Industry Brackets

Pair of brackets made of zinc-plated steel with rings and vibration-damping packing. Suitable for Industry manifold.

SIZE

Ø 2"

CODE

1141000



Wall cabinet

Cabinet for wall installation. It is made of powder-coated steel, thickness 20 cm, height 80 cm. It is open on the back, and it has dead holes for side entrances and a white metal powder-coated door and lockset. It is placed once the installation has been completed.

outlets manifolds	A	B	C	cabinet code
5+5	320	440	780	1158076
6+6	400	520	780	1158076
7+7	480	600	780	1158076
8+8	560	680	1030	1158101
9+9	640	760	1030	1158101
10+10	720	840	1030	1158101
11+11	800	920	1200	1158121
12+12	880	1000	1200	1158121
13+13	960	1080	1400	1158141
14+14	1040	1160	1400	1158141
15+15	1120	1240	1400	1158141

Dimensional quotas

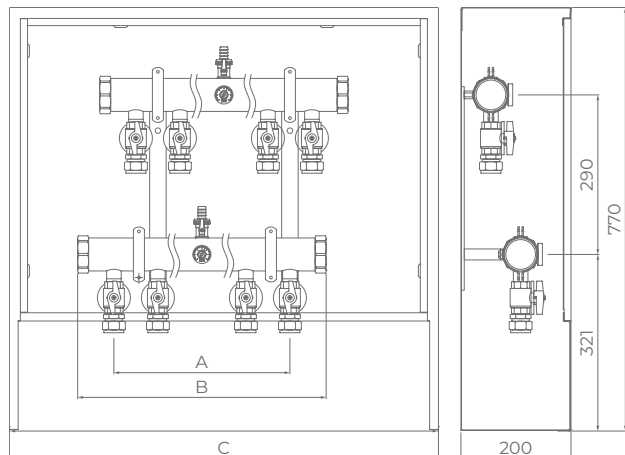



Suitable for all industrial systems

RDZ TECH PE-Xc Pipe Ø 20 Interior Layer

Pipe made of high-density electrophysically cross-linked polythylene with oxygen barrier. This pipe is produced according to DIN EN ISO 15875/2 and DIN 16892 guaranteeing even and stable cross-links and constant characteristics over time

DIAMETER	ROLL	CODE
20 mm	240 m	1012240
20 mm	600 m	1012600

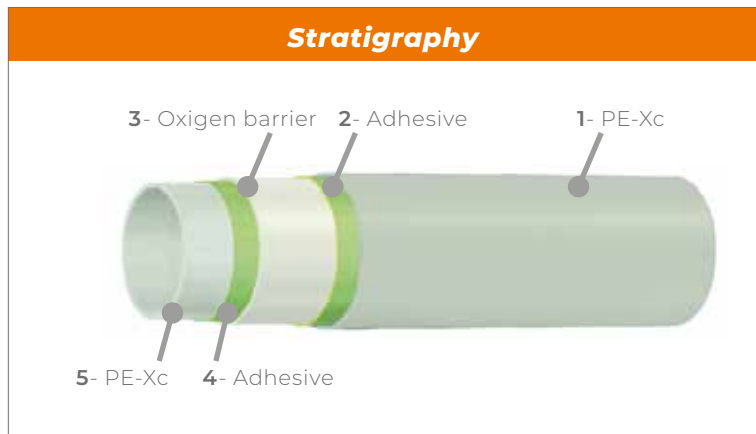

Application field	CLASS 4	For use with hot and cold water (T _{max} 70 °C)
	CLASS 5	For use with hot and cold water (T _{max} 90 °C)

Outside diam. (mm)	Thickness (mm)	Weight (g/m)	CLASS 4 (bar)	CLASS 5 (bar)	Water content (l/m)
20	2	120	8	6	0.20

Pipe Feature	Value	Unit	Standard
Standard			DIN EN ISO 15875 / DIN 4726
Density	0.945	g/cm ³	ISO 1183
Degree of cross-linking	≥ 60	%	
Ultimate Tensile Stress at 20 °C	24-26	N / mm ²	UNI EN ISO 527-2 / EN 60811-1
Elongation at break a 20 °C	400 ÷ 600	%	DIN EN ISO 6259-1 / EN 60811-1
Thermal conductivity	0.41	W / (m · K)	DIN 52612
Oxygen tightness	≤ 0.32	mg O ₂ / (m ² · d)	DIN 4726
Thermal expansion coefficient at 20 °C	1.5 · 10 ⁻⁴	m / (m · K)	
Softening temperature	> 130	°C	
Maximum ovalization	1.2	mm	
Roughness factor	0.0015		



Suitable for all industrial systems

Easy pipe PE-RT 5L Ø 20 mm

RDZ EASY 5-layer PE-RT (non-crosslinked polyethylene of raised temperature) provided with EVOH anti-oxygen according to DIN 4726, it is suitable for underfloor heating and cooling systems

DIAMETER	ROLL	CODE
20 mm	600 m	1014766

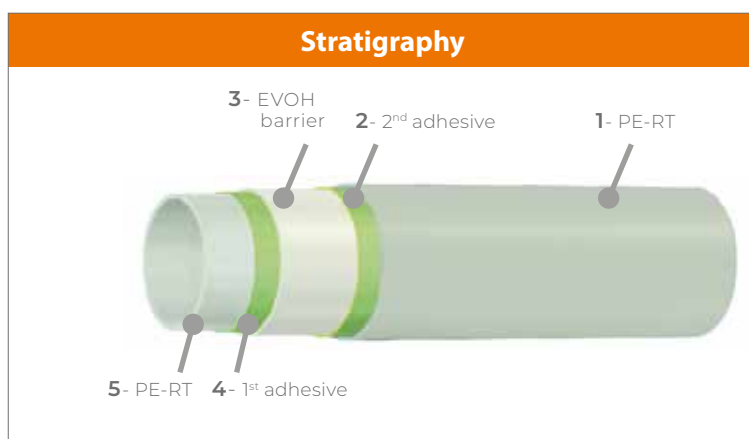

Application field	CLASS 4	For use with hot and cold water (T_{max} 70 °C)	pressure 8 bar
	CLASS 5	For use with hot and cold water (T_{max} 90 °C)	pressure 6 bar

d_n (mm)	e_n (mm)	Water content (l/m)
17	2	0.13

d_n = outer diameter, e_n = wall thickness,

Pipe Feature	Value	Unit
Density	> 941	Kg/m ³
Roughness factor	0.007	mm
Tensile resistance	> 22	N/mm ²
Elongation at break	> 400	%
Thermal expansion coefficient	1.8	10 ⁻⁴ /K
Thermal conductivity at 60°C	0.41	W/(m·K)
VICAT softening point	124.7	°C
Oxidation induction time (OIT)	> 40	min
Permeability O ₂ at 40 °C	< 0,1	g/ m ³ · d

RDZ Tech PE-Xa Pipe Ø 25 Interior Layer

RDZ Tech PE-Xa pipe Ø 25-20.4 made of high-density polyethylene with type-a cross-linking. This pipe is produced according to UNE-EN ISO 15875: 2004 European regulations and ISO 9001.



Suitable for Pvc bar and Industrial mesh system

DIAMETER	ROLL	CODE
25 mm	200 m	1013920
25 mm	600 m	1013900

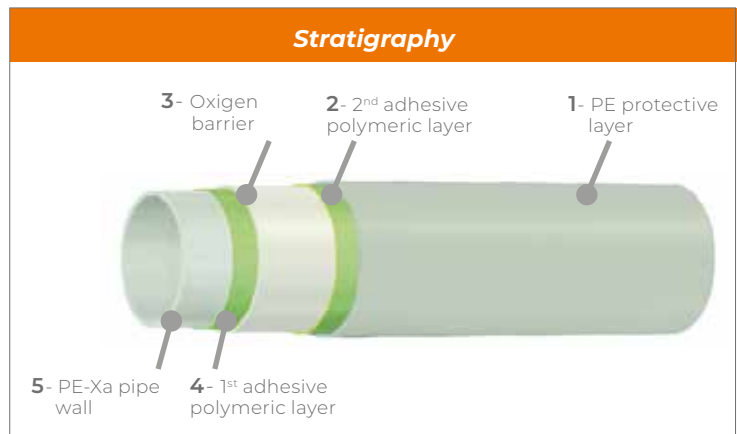

Application field	CLASS 4	For use with underfloor heating and low temperature radiators (T _{max} 70 °C)
	CLASS 5	For use with high temperature radiators (T _{max} 90 °C)

Outside diam. (mm)	Thickness (mm)	Weight (g/m)	CLASS 4 (bar)	CLASS 5 (bar)	Water content (l/m)
25	2.3	174	8	6	0.326

Pipe Feature	Value	Unit	Standard
Density	938 ÷ 951	Kg/m ³	UNI EN ISO 15875: 2004 e ISO 9001
Degree of cross-linking	> 70	% weight	
Roughness factor	0.007	mm	
Thermal conductivity	0.35÷0.38	W/(m·K)	
VICAT temperature	130÷132	°C	
Permeability O ₂	0.08	g/(m ³ ·d)	
Linear extension coefficient	0.026	mm/(m·K)	
Tensile resistance	> 19	N/mm ²	
Elongation at break	> 400	%	
Modulus of elasticity at 20 °C	> 800	N/mm ²	
Internal pressure resistance s=2.5 Mpa, 110 °C	> 1	Year	

OTHER ACCESSORIES



Pipe Band

Pipe bands made of plastic and used to block pipes in industrial systems.

SIZE	CODE
20 cm	1130001



Joint Sleeve

Joint sleeve made of polypropylene, which is ideal to protect expansion joints.

SIZE	CODE
L. 300 - Ø 28 mm	1142028
L. 500 - Ø 40 mm	1142040



Light Felt

Light felt made of polypropylene flocks, thickness 5 mm, density 500 g/m². It is used for thermal insulation. Height: 2 m. Package: 50-m rolls.

SIZE	CODE
sp. 5 mm x h. 2 m	1901000

Our history



*For over 45 years
we have been
a worldwide reference company
in the field of heating and
cooling systems.
We work with passion
to ensure indoor comfort
thanks to innovative solutions,
specifically for residential,
commercial and
industrial buildings.
We design and produce
high-efficient and
high-performance systems
which offer energy saving,
comfort and health
throughout the year.
Invisible solutions
spreading a unique sensation
of wellbeing in any room.*



